

A User's Guide to the Lout Document Formatting System

Jeffrey H. Kingston

Version 3.38
October 2008

Preface

This User's Guide brings together in one document everything needed for the day-to-day use of Version 3 of the Lout document formatting system.

There are three other documents describing Lout: the Expert's Guide [5], which you need if you want to add new features to Lout; a journal paper on the design and implementation of Lout [3]; and a set of overhead transparencies [4] that cover much the same ground as this Guide. These documents are all distributed with the software.

Lout is distributed free of charge under the GNU Public License. The primary source is directory

`ftp://ftp.it.usyd.edu.au/jeff/lout`

containing a gzipped tar file of the current version (currently `lout-3.38.tar.gz`), and various other things including a PostScript version of this guide. The distribution contains source code, libraries, documentation, license, and installation instructions.

A mailing list has been set up for discussion of all topics related to Lout. To subscribe (or unsubscribe), visit

`http://lists.planix.com/mailman/options.cgi/lout-users/`

After subscribing, to post an item send email to `lout-users@lists.planix.com`; it will be forwarded to all subscribers via email. There is also a Lout web site at `http://lout.wiki.sourceforge.net/`.

Lout began in 1984 as a research project into the design of a high-level language for document formatting. At that time my name for the subject was 'document layout,' and this terminology survives in the name 'Lout'. The initial design was strongly influenced by Brian W. Kernighan and Lorinda L. Cherry's eqn equation formatter [2], and also by Brian K. Reid's Scribe system [9]. That research phase ended in October 1991 with the first public release of Lout.

Since then the system has been steadily improved and extended. Optimal paragraph breaking and automatic hyphenation were copied from Donald E. Knuth's \TeX system [6], and the optimal paragraph breaking algorithm was applied to the problem of producing optimal page breaks. The first implementations of horizontal galleys and optimal page breaking were by my student Gabor Inokai. Vincent Tan contributed the PDF back end. Ludovic Courtès contributed the @Math package. Valeriy E. Ushakov smoothed the path for many people, by his contributions to improving Lout's robustness, and his tireless management of and responses to the Lout mailing list. The current mailing list maintainer is Greg Woods. The number of other people who have offered comments and suggestions to me is so great that it is quite out of my power to acknowledge them individually. I hope that seeing their ideas adopted will be thanks enough.

Jeffrey H. Kingston
School of Information Technologies
The University of Sydney 2006, Australia
`jeff@it.usyd.edu.au`

Contents

Preface	ii
Chapter 1. The Basics	1
1.1. Getting started	1
1.2. Objects, symbols, options, and lengths	3
1.3. Spaces and braces	6
1.4. Characters	7
1.5. The empty object	12
1.6. Fonts and font sizes	12
1.7. Headings	16
1.8. Starting a new line, paragraph, or page	17
1.9. Paragraph breaking	18
1.10. Line spacing	23
1.11. Hyphenation	24
1.12. Margin kerning	24
1.13. Underlining	25
1.14. Languages other than English	26
1.15. The current date and time	28
1.16. Superscripts and subscripts	29
1.17. Verbatim and piped text	29
1.18. Drop capitals	31
1.19. Alternative conventions for white space	31
Chapter 2. Adding Structure to Documents	33
2.1. Displays	33
2.2. Lists	34
2.3. Footnotes and endnotes	41
2.4. Margin notes and arbitrary placement	43
2.5. Theorems, lemmas, corollaries, definitions, propositions, examples, and claims	45
2.6. Figures and tables	47
2.7. Large-scale structure: chapters, sections, etc.	51
2.8. Cross references and links	54
2.9. Tables of contents	57
2.10. Glossaries	59

2.11. Indexes	62
2.12. Multiple columns	70
2.13. Defining new symbols	70
Chapter 3. Types of Documents	74
3.1. Ordinary documents	74
3.2. Technical reports	78
3.3. Books	84
3.4. Overhead transparencies	92
3.5. Stand-alone illustrations	96
3.6. Plain text documents	98
3.7. PDF (Adobe Portable Document Format) documents	99
3.8. Organizing large documents	100
Chapter 4. Changing the Overall Format	102
4.1. Setup files	102
4.2. Page size and page orientation	105
4.3. Page margins, page boxes, and page backgrounds	107
4.4. Page numbers and running headers	110
Chapter 5. References	115
5.1. Setting up a bibliographic database	115
5.2. Citation	116
5.3. Labelled (as opposed to numbered) references	118
5.4. Constructing database entries	119
5.5. Changing the appearance of citations and the reference list	123
5.6. Creating your own entry types and formats	126
Chapter 6. Tables	129
6.1. Getting started	129
6.2. Changing the appearance of cells	131
6.3. Changing the appearance of rows	133
6.4. Rules	134
6.5. Margins	136
6.6. Cell width and height	137
6.7. Indenting and struts	138
6.8. Aligned columns	138
6.9. Spanning columns and rows	140
6.10. Vertical alignment of tables	143

6.11. Multi-page tables	144
6.12. Plain text tables	147
6.13. Changing the overall format	148
6.14. Summary of options	149
Chapter 7. Mathematics	153
7.1. Getting started	153
7.2. Commonly used symbols	154
7.3. Matrices	155
7.4. Displaying equations	158
7.5. Defining new mathematical symbols	160
7.6. Summary	161
Chapter 8. Basic Graphics	170
8.1. Colour	170
8.2. Textures	171
8.3. Boxes and rules	173
8.4. Outlined words	177
8.5. Rotation	178
8.6. Scaling	178
8.7. Clipping	180
8.8. Mirror reflections	181
8.9. Including an illustration	182
8.10. Precise object placement	183
Chapter 9. Diagrams	188
9.1. Introduction	188
9.2. Nodes	190
9.3. Links	195
9.4. Tags	199
9.5. Labels	201
9.6. Positioning	206
9.7. Trees	208
9.8. Syntax diagrams	213
9.9. Errors	220
9.10. Expert usage: defining new shapes	221
9.11. Expert usage: numbers, lengths, angles, and points	225
9.12. Summary	228

Chapter 10. Graphs	245
10.1. Introduction	245
10.2. Changing the overall appearance of the graph	246
10.3. Captions	249
10.4. Ticks and labels	251
10.5. Changing the appearance of the data	254
10.6. Placing arbitrary objects on the graph	260
10.7. Mathematical functions, loops, and tests	260
10.8. Adding a key to the graph	263
10.9. Errors	265
10.10. Summary	265
Chapter 11. Pie Graphs	270
11.1. Introduction	270
11.2. Changing the appearance of slices	271
11.3. Changing the overall appearance of the pie graph	274
11.4. Captions	276
11.5. Labels	277
11.6. Errors	282
11.7. Summary	283
Chapter 12. Computer Programs	284
12.1. Typesetting computer programs independently of any document	284
12.2. Typesetting computer programs as part of a larger document	285
12.3. Changing the appearance of a program	287
12.4. Changing the appearance of all programs simultaneously	289
12.5. Dealing with tab characters in programs	291
12.6. Dealing with formfeed characters in programs	292
12.7. Embedding Lout commands within program comments	293
12.8. Embedding program text within program comments	294
12.9. Reading and selecting program text from separate files	295
12.10. Error messages	296
12.11. Notes on Perl and Pod	296
Chapter 13. Pascal and Modula-2 Programs	299
Appendix A. Lout Quick Reference Guide	302

Appendix B. Bypass Symbols 304

Appendix C. Lots more colours 306

References 310

Index 311

Chapter 1. The Basics

The Lout document formatting system has been designed with the needs of the ordinary user very much in mind. Although the features of Lout are virtually endless, and include mathematical equations, diagrams made from lines and shapes, bibliographic databases, and so on, the system is very simple to use.

1.1. Getting started

Suppose you want to produce the following little document:

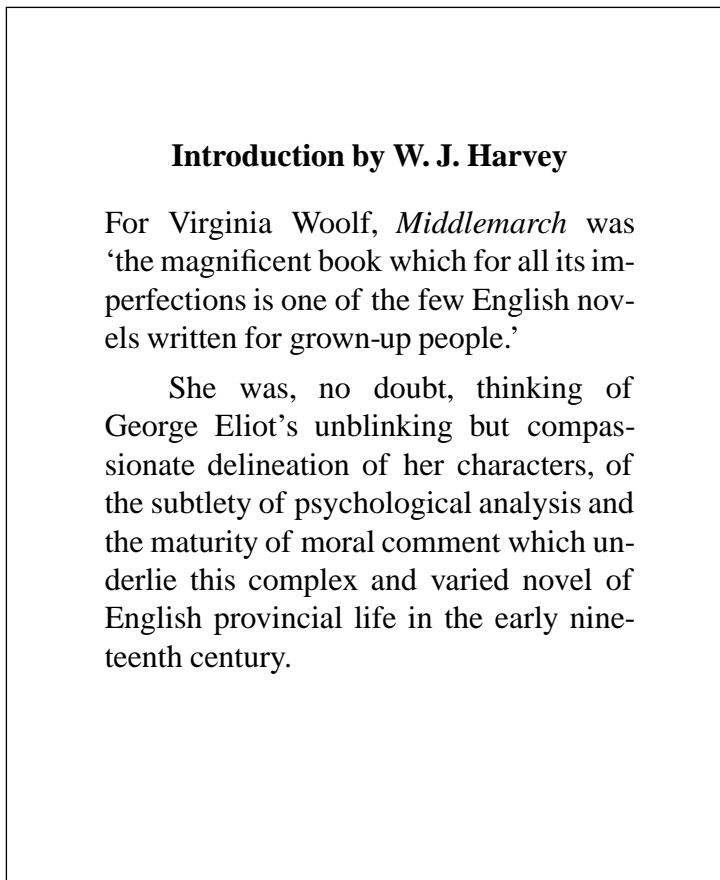

Unlike word processing and desktop publishing systems, with Lout you cannot see and edit your document on the screen in this finished form. Instead, you edit an ordinary text file, in which your text is augmented with symbols that mark out the headings, paragraphs, and so on. Although it would be nice to be able to see and edit the finished form, working with a text file and symbols does have some compensating advantages.

The first step in producing your introduction to *Middlemarch* is to use the text editor of your choice to construct this text file:

```

@SysInclude { doc }
@Doc @Text @Begin
@Display @Heading { Introduction by W. J. Harvey }
For Virginia Woolf, @I Middlemarch was 'the magnificent book which for all its
imperfections is one of the few English novels written for grown-up people.'
@PP
She was, no doubt, thinking of George Eliot's unblinking but compassionate
delineation of her characters, of the subtlety of psychological analysis and
the maturity of moral comment which underlie this complex and varied novel
of English provincial life in the early nineteenth century.
@end @Text

```

Comparing this with the finished form, it's easy to guess that @I is a symbol that causes the following thing to be printed in italics, and that @PP starts a new paragraph. The other symbols are not much harder.

@SysInclude { doc } instructs Lout to read a *setup file* called doc, in which the symbols are defined. Setup files are the subject of Chapter 4, but you can go a long way without worrying about them. @Doc @Text @Begin and @End @Text have no visible effect, but they must bracket the document as a whole. Again, you don't have to know what they are for.

That explains everything except the part that produces the heading. It's an interesting glimpse of the way that Lout's symbols cooperate with each other:

```
@Display @Heading { Introduction by W. J. Harvey }
```

The @Display symbol does the centring and leaves space above and below, while @Heading switches to a bold font. The braces group the words of the heading together so that these symbols apply to all of it; without them they would apply to just the first word. All this is explained in detail in Sections 1.2 and 1.3.

Once the file is ready, the next step is to get it processed by the Bassar Lout interpreter. If the file's name is intro, the command for this on the Unix¹ operating system is

```
lout intro > intro.ps
```

The output is the PostScript² file intro.ps, which is suitable for printing on many laser printers and other devices. There are programs that show you the result on your screen as well, although you won't be able to edit it there. You can also get plain text output (Section 3.6) and PDF output.

There are a few points that often confuse people as they begin, so we'll treat them briefly now with pointers to later sections where they are done properly.

Some characters are symbols that produce special effects – for example, { and } produce grouping – and to turn off these effects the characters must be enclosed in double quotes: "{ produces {. The complete set of these special characters is

```
/ | & { } # @ ^ ~ \ "
```

¹Unix is a trademark.

²PostScript is a trademark of Adobe Systems, Inc.

Section 1.4 treats unusual characters in full detail.

Symbols like @Doc and @Text must be separated from each other by one or more spaces, otherwise Lout will think they are part of one symbol. See Section 1.3 for the details.

People familiar with other systems might expect that leaving a blank line would cause Lout to start a new paragraph; but this is not so, you must use a paragraph symbol. Lout will ordinarily take notice of how many spaces you type between words (Section 1.3), but it will mimic the spacing rules of two other systems, troff and T_EX, if you prefer (Section 1.19).

When Lout runs, you might see some error messages containing the words ‘unresolved cross reference’ and ‘no destination point’ – not on file intro above, but on more complicated ones (anything with a footnote, for example). These just mean that you have to run the lout command again to finish off the complicated things (Section 2.8), and they will gradually go away. Of course, if you see error messages about missing braces, unknown symbols, and so on, you need to revise your file. Lout will tell you the line number of the problem, and how far along the line it is.

WARNING: Lout allows documents to cause arbitrary system commands to be executed. These typically do useful things such as format computer programs and uncompress graphics files, but it is possible for a malicious person to send you a document which includes a command to delete all your files, send abusive mail to the President of the United States in your name, etc. You can protect yourself against this possibility by using the ‘safe execution’ flag:

```
lout -S suspect.document > out.ps
```

Then no system commands will be executed; instead, Lout will print them so that you can confirm for yourself that they are safe before running again without the flag. These system commands are Lout’s only potentially unsafe features, but you also need to worry about whether the resulting PostScript file contains malicious code, since the document may direct Lout to include arbitrary PostScript code in the output. The safe execution of PostScript programs is a matter for PostScript interpreters, not for Lout. For example, the popular Ghostview program has a -safer command line option, which is rumoured to disable unsafe PostScript features.

1.2. Objects, symbols, options, and lengths

Lout is not concerned with the exact shapes of individual characters, only with the rectangular areas they occupy:



When letters join together into a word, the result is a larger rectangle enclosing them all:

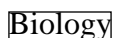

When words join into lines we get even larger rectangles:

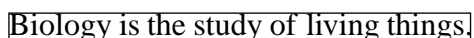

and so on up through paragraphs and columns to the largest rectangles, which are pages. We call any such rectangle, whether made up of one character, one word, one line, one paragraph, one

page, or anything else, an *object*.

We also often say, for example, ‘the object @l { Hello world },’ referring to a piece of Lout’s input as an object. This makes sense because we are anticipating the result produced, in this case the object *Hello world*. It’s true that if a line break happens to fall between *Hello* and *world*, the result of @l { Hello world } is not a single rectangle. We answer this by thinking of objects as existing before paragraph breaking rearranges them.

Not everything is an object, however. @l alone is not an object, merely a symbol with the potential of producing an object when given an object to work on. To understand this, ask yourself what rectangle @l alone could possibly represent: there is no such rectangle.

It helps to imagine the assembly of objects taking place before your eyes. Look at Hello and imagine the objects H, e, l, l, o being assembled into the larger object Hello; look at Hello world and imagine Hello and world being assembled into Hello world. When looking at

```
@l { Hello world }
```

you need to imagine the @l symbol consuming the following object, Hello world, and replacing it with the object *Hello world*. Here is another example:

```
@CurveBox { Hello world }
```

The @CurveBox symbol (Section 8.3) consumes Hello world and replaces it with the object

```
Hello world
```

This brings us to a basic principle of Lout: *Where you can put one object, you can put any object*. A few examples will show the vast range of possibilities opened up by this:

```
@CurveBox { @l Hello world }
```

produces

```
Hello world
```

It doesn’t bother @CurveBox if one of the words inside it is in italics. Next:

```
@l @CurveBox { Hello world }
```

produces

```
Hello world
```

The object following @l cannot be just @CurveBox, since that is not an object by itself (it needs to be applied to some object first). So the object following @l is @CurveBox { Hello world }, and it is this that is consumed by @l and modified. The @l symbol is happy to hunt through the object looking for words to italicize. We could go on indefinitely in this way, producing

```
Hello world
```

for example by `@CurveBox { @CurveBox Hello @CurveBox world }`.

Symbols like `@CurveBox` often have *options*, which are subsidiary symbols that modify the result. For example, `@CurveBox` has `margin` and `paint` options:

```
@CurveBox
  margin { 0.5c }
  paint { lightgrey }
{ Hello world }
```

Options come immediately after the main symbol, before any following object. Each consists of the option name followed by the value we want the option to have, always enclosed in braces. Setting out options on separate lines as we have done above makes them easy to see but is not compulsory (end of line and space are the same to Lout). The result, naturally enough, is a curved box with a 0.5 centimetre margin around its contents, painted light grey:



Options are optional: if you leave out an option, Lout supplies a sensible *default* value for it. Options may be given in any order. They are a very useful way of adding flexibility to symbols without cluttering things up when they aren't needed. They also help with learning: you can learn the basic symbol first and worry about the options later.

Whenever a length is required, as in the `margin` option above, it may be given using any one of the following seven units of measurement:

c	Centimetres
i	Inches (1i = 2.54c)
p	Points (72p = 1i)
m	Ems (12m = 1i)
f	1f is the current font size
s	1s is the current width of a space character
v	1v is the current inter-line spacing

The first four all define absolute distances and are strictly interchangeable. It is traditional to measure font sizes in points; typical sizes are 12p and 10p, but fractional sizes are allowed.

If you use the `f` unit, the length will depend on the current font size. This can be very useful. For example, the default value of the `margin` option of `@CurveBox` is `0.3f` (0.3 times the current font size). If you use a large font, for example in an overhead transparency, you get a correspondingly large margin without having to ask for it.

The `s` and `v` units are less useful. The `v` unit is used within paragraph symbols (Section 1.8) to ensure that the space between paragraphs widens with the inter-line spacing.

1.3. Spaces and braces

Every symbol in Lout either consists entirely of letters (@ is considered to be a letter) or entirely of punctuation characters. Here are some examples of each type:

<i>From letters</i>	<i>From punctuation</i>
@PP	{
margin	}

Now if two symbols made from letters are run together like this:

@CurveBox@I Hello *(wrong!)*

Lout will take this to mean one word or symbol called @CurveBox@I, which is wrong. In the same way, a letter-type symbol cannot be run together with a word. However, punctuation-type symbols can be run together with anything. For example, in

@CurveBox{ Hello @I { world } }.

Lout understands that @CurveBox and { are separate, and it also sorts out } } into two right brace symbols and a full stop. It might seem strange to treat punctuation and letters so differently, but computer programming languages have done it like this for many years, and it works well. This is the first use for spaces: to separate letter-type symbols from each other and from words.

To see the second use for spaces, consider two words side by side:

Hello world

We want this to produce Hello world, so a space between two words in the input must mean a space between them in the result. Apply the golden rule (where you can put one object, you can put any object) and you get this: *a space between two objects in the input produces a space between them in the result.* For example,

@CurveBox Hello @CurveBox world

produces

Hello world

The space between the two objects @CurveBox Hello and @CurveBox world appears between them in the result; the other two spaces do not separate objects so do not appear in the result.

Two objects may be separated by a number of spaces other than one. If they are separated by no spaces, they will appear immediately adjacent in the result; if separated by two spaces, they will appear two spaces apart; and so on. In English it is correct to leave two spaces between the end of one sentence and the beginning of the next, for example. See Section 1.19 for two alternative ways to interpret white space in Lout.

Occasionally the two uses for spaces conflict. For example, to produce

Hello world

we need to have no spaces between the two objects, but then Hello and the following @CurveBox would be run together, which will not work. The solution is to use braces:

```
{ @CurveBox Hello }{ @CurveBox world }
```

None of the six spaces in this example lie between two objects.

However, the main use of braces is to inform Lout that the object within them is to be kept together, so that any nearby symbols are to apply to all of it. For example, leaving the braces out of @l { Hello world } would mean that @l applies only to Hello.

When an object-consuming symbol like @l is followed by an object enclosed in braces, that is the object consumed. For example,

```
This is @l { absolutely necessary }, since otherwise ...
```

produces

```
This is absolutely necessary, since otherwise ...
```

with the object *absolutely necessary* italicized, but not the following comma. If there are no braces, the object consumed is everything up to the next object-separating space:

```
This is @l necessary, since otherwise ...
```

produces

```
This is necessary, since otherwise ...
```

with an undesirable italic comma. In practice, this means you can avoid braces only when italicizing a single word with no punctuation attached.

One common pitfall is to use unnecessary braces, like this:

```
@l { @CurveBox { Hello world } }           (bad!)
```

Another is to think that all spaces produce space in the result, and so write

```
@l{@CurveBox{Hello world}}                (worse!)
```

Use braces only when necessary, and add extra spaces where they do not separate objects, and your documents will be far easier to read while you are working on them. Don't be fooled by the argument that says it doesn't matter because it doesn't affect the final printed result.

1.4. Characters

The usual way to get characters into a document is simply to type them as we have been doing all along. However, for some characters this is not possible, either because they have some special meaning, as { and } do, or because the keyboard has no button for them. This section explains how to get every possible character: every printable character in the ISO-LATIN-1 character set, every character in the Adobe Systems Symbol font, plus the characters ,, ,, ..., Œ, œ, “, ”, fi, fl, −, —, •, †, ‡, f, /, and €. If it exists at all, you will find it here. ISO-LATIN-2

and Russian characters are available separately. In principle, there is no limit to the characters available, but to go beyond those given in this section requires expertise in defining encoding vectors and fonts [5].

First up we have the characters that you get simply by typing them. The characters themselves are shown at the left, and what you type to get them at the right:

!	!	\$	\$	%	%	'	'	(())
*	*	+	+	,	,	-	-	0	0	1	1
2	2	3	3	4	4	5	5	6	6	7	7
8	8	9	9	:	:	;	;	<	<	=	=
>	>	?	?	A	A	B	B	C	C	D	D
E	E	F	F	G	G	H	H	I	I	J	J
K	K	L	L	M	M	N	N	O	O	P	P
Q	Q	R	R	S	S	T	T	U	U	V	V
W	W	X	X	Y	Y	Z	Z	[[]]
-	-	'	'	a	a	b	b	c	c	d	d
e	e	f	f	g	g	h	h	i	i	j	j
k	k	l	l	m	m	n	n	o	o	p	p
q	q	r	r	s	s	t	t	u	u	v	v
w	w	x	x	y	y	z	z				

Next come characters that have buttons but have a special meaning if they are typed directly, and consequently have to be enclosed in double quotes to turn off this meaning:

"	"\""	#	"#"	&	"&"	/	"/"		
@	"@"	\	"\""	^	"^"	{	"{"		
	" "	}	"}"	~	"~"	" "			(space character)

If you think you want ", you probably really want “ and ”, for which see below. You can place whole sequences of characters, special or not, inside one pair of double quotes:

```
jeff/includes/su_crest.eps      "jeff/includes/su_crest.eps"
"@PP"                          "\"@PP\""
```

The following characters have been deemed important enough to deserve their own symbols:

“	“	”	”	—	--
”	”	---	---
•	@Bullet	*	@Star	¶	@ParSym
§	@SectSym	†	@Dagger	‡	@DaggerDbI
·	@CDot	£	@Sterling	¥	@Yen
f	@Florin	°	@Degree	'	@Minute
”	@Second	◇	@Lozenge	×	@Multiply
÷	@Divide	©	@CopyRight	®	@Register
™	@TradeMark	€	@Euro		

Next we have the complete ISO-LATIN-1 character set, whose members you get with the @Char

symbol followed by the name of the character you want:

@Char space	! @Char exclam	" @Char quotedbl	# @Char numbersign
\$ @Char dollar	% @Char percent	& @Char ampersand	' @Char quoteright
(@Char parenleft) @Char parenright	* @Char asterisk	+ @Char plus
, @Char comma	- @Char hyphen	. @Char period	/ @Char slash
0 @Char zero	1 @Char one	2 @Char two	3 @Char three
4 @Char four	5 @Char five	6 @Char six	7 @Char seven
8 @Char eight	9 @Char nine	: @Char colon	; @Char semicolon
< @Char less	= @Char equal	> @Char greater	? @Char question
@ @Char at	A @Char A	B @Char B	C @Char C
D @Char D	E @Char E	F @Char F	G @Char G
H @Char H	I @Char I	J @Char J	K @Char K
L @Char L	M @Char M	N @Char N	O @Char O
P @Char P	Q @Char Q	R @Char R	S @Char S
T @Char T	U @Char U	V @Char V	W @Char W
X @Char X	Y @Char Y	Z @Char Z	[@Char bracketleft
\ @Char backslash] @Char bracketright	^ @Char asciicircum	_ @Char underscore
‘ @Char quoteleft	a @Char a	b @Char b	c @Char c
d @Char d	e @Char e	f @Char f	g @Char g
h @Char h	i @Char i	j @Char j	k @Char k
l @Char l	m @Char m	n @Char n	o @Char o
p @Char p	q @Char q	r @Char r	s @Char s
t @Char t	u @Char u	v @Char v	w @Char w
x @Char x	y @Char y	z @Char z	{ @Char braceleft
@Char bar	} @Char braceright	~ @Char asciitilde	ı @Char dotlessi
` @Char grave	´ @Char acute	^ @Char circumflex	~ @Char tilde
- @Char macron	˘ @Char breve	· @Char dotaccent	¨ @Char dieresis
° @Char ring	¸ @Char cedilla	˜ @Char hungarumlaut	ł @Char ogonek
˘ @Char caron	@Char space	¡ @Char exclamdown	¢ @Char cent
£ @Char sterling	¤ @Char currency	¥ @Char yen	‡ @Char brokenbar
§ @Char section	¨ @Char dieresis	© @Char copyright	ª @Char ordfeminine
« @Char guillemotleft	¬ @Char logicalnot	- @Char hyphen	® @Char registered
- @Char macron	° @Char degree	± @Char plusminus	² @Char twosuperior
³ @Char threesuperior	´ @Char acute	μ @Char mu	¶ @Char paragraph
· @Char periodcentered	¸ @Char cedilla	¹ @Char onesuperior	º @Char ordmasculine
» @Char guillemotright	¼ @Char onequarter	½ @Char onehalf	¾ @Char threequarters
¿ @Char questiondown	À @Char Agrave	Á @Char Aacute	Â @Char Acircumflex
Ã @Char Atilde	Ä @Char Adieresis	Å @Char Aring	Æ @Char AE
Ç @Char Ccedilla	È @Char Egrave	É @Char Eacute	Ê @Char Ecircumflex
Ë @Char Edieresis	Ì @Char Igrave	Í @Char Iacute	Î @Char Icircumflex
Ï @Char Idieresis	Ð @Char Eth	Ñ @Char Ntilde	Ò @Char Ograve
Ó @Char Oacute	Ô @Char Ocircumflex	Õ @Char Otilde	Ö @Char Odieresis
× @Char multiply	Ø @Char Oslash	Ù @Char Ugrave	Ú @Char Uacute
Û @Char Ucircumflex	Ü @Char Udieresis	Ý @Char Yacute	Þ @Char Thorn
ß @Char germandbls	à @Char agrave	á @Char aacute	â @Char acircumflex
ã @Char atilde	ä @Char adieresis	å @Char aring	æ @Char ae
ç @Char ccedilla	è @Char egrave	é @Char eacute	ê @Char ecircumflex
ë @Char edieresis	ì @Char igrave	í @Char iacute	î @Char icircumflex
ï @Char idieresis	ð @Char eth	ñ @Char ntilde	ò @Char ograve
ó @Char oacute	ô @Char ocircumflex	õ @Char otilde	ö @Char odieresis
÷ @Char divide	ø @Char oslash	ù @Char ugrave	ú @Char uacute
û @Char ucircumflex	ü @Char udieresis	ý @Char yacute	þ @Char thorn
ÿ @Char ydieresis			

Of course, many of these characters can also be typed directly, or with the aid of double quotes, as we have seen. If your keyboard has accented characters on it, you can type them directly too;

if not, you need to use the @Char symbol, in which case you will probably need braces as well:

$\text{gar}\{\text{@Char ccedilla}\text{on}$

to distinguish the @Char symbol and the character name from adjacent letters.

Next we have the Adobe Systems Symbol font, a treasure trove of exotic characters obtained with the @Sym symbol:

@Sym space	! @Sym exclam	∀ @Sym universal	# @Sym numbersign
∃ @Sym existential	% @Sym percent	& @Sym ampersand	☞ @Sym suchthat
(@Sym parenleft) @Sym parenright	* @Sym asteriskmath	+ @Sym plus
, @Sym comma	− @Sym minus	. @Sym period	/ @Sym slash
0 @Sym zero	1 @Sym one	2 @Sym two	3 @Sym three
4 @Sym four	5 @Sym five	6 @Sym six	7 @Sym seven
8 @Sym eight	9 @Sym nine	: @Sym colon	; @Sym semicolon
< @Sym less	= @Sym equal	> @Sym greater	? @Sym question
≡ @Sym congruent	A @Sym Alpha	B @Sym Beta	X @Sym Chi
Δ @Sym Delta	E @Sym Epsilon	Φ @Sym Phi	Γ @Sym Gamma
H @Sym Eta	I @Sym Iota	ϑ @Sym theta1	K @Sym Kappa
Λ @Sym Lambda	M @Sym Mu	N @Sym Nu	O @Sym Omicron
Π @Sym Pi	Θ @Sym Theta	P @Sym Rho	Σ @Sym Sigma
T @Sym Tau	Υ @Sym Upsilon	ς @Sym sigma1	Ω @Sym Omega
Ξ @Sym Xi	Ψ @Sym Psi	Z @Sym Zeta	[@Sym bracketleft
∴ @Sym therefore] @Sym bracketright	⊥ @Sym perpendicular	_ @Sym underscore
√ @Sym radicalex	α @Sym alpha	β @Sym beta	χ @Sym chi
δ @Sym delta	ε @Sym epsilon	φ @Sym phi	γ @Sym gamma
η @Sym eta	ι @Sym iota	φ @Sym phi1	κ @Sym kappa
λ @Sym lambda	μ @Sym mu	ν @Sym nu	ο @Sym omicron
π @Sym pi	θ @Sym theta	ρ @Sym rho	σ @Sym sigma
τ @Sym tau	υ @Sym upsilon	ω @Sym omega1	ω @Sym omega
ξ @Sym xi	ψ @Sym psi	ζ @Sym zeta	{ @Sym braceleft
@Sym bar	} @Sym braceright	~ @Sym similar	Υ @Sym Upsilon1
′ @Sym minute	≤ @Sym lessequal	/ @Sym fraction	∞ @Sym infinity
f @Sym florin	♣ @Sym club	♦ @Sym diamond	♥ @Sym heart
♠ @Sym spade	↔ @Sym arrowboth	← @Sym arrowleft	↑ @Sym arrowup
→ @Sym arrowright	↓ @Sym arrowdown	° @Sym degree	± @Sym plusminus
″ @Sym second	≥ @Sym greaterequal	× @Sym multiply	∝ @Sym proportional
∂ @Sym partialdiff	• @Sym bullet	÷ @Sym divide	≠ @Sym notequal
≡ @Sym equivalence	≈ @Sym approxequal	… @Sym ellipsis	@Sym arrowvertex
— @Sym arrowhorizex	↵ @Sym carriagereturn	ℵ @Sym aleph	℘ @Sym lfraktur
ℜ @Sym Rfraktur	∅ @Sym weierstrass	⊗ @Sym circlemultiply	⊕ @Sym circleplus
∅ @Sym emptyset	∩ @Sym intersection	∪ @Sym union	⊃ @Sym propersuperset
⊃ @Sym reflexsuperset	⊄ @Sym notsubset	⊂ @Sym propersubset	⊆ @Sym reflexsubset
∈ @Sym element	∉ @Sym notelement	∠ @Sym angle	∇ @Sym gradient
® @Sym registerserif	© @Sym copyrightserif	™ @Sym trademarkserif	∏ @Sym product
√ @Sym radical	· @Sym dotmath	¬ @Sym logicalnot	∧ @Sym logicaland
∨ @Sym logicalor	↔ @Sym arrowdblboth	⇐ @Sym arrowdblleft	↑ @Sym arrowdblup
⇒ @Sym arrowdblright	↓ @Sym arrowdbldown	◇ @Sym lozenge	∠ @Sym angleleft
® @Sym registersans	© @Sym copyrightsans	™ @Sym trademarksans	∑ @Sym summation
(@Sym parenlefttp	@Sym parenleftex	(@Sym parenleftbt	[@Sym bracketlefttp
@Sym bracketleftex	[@Sym bracketleftbt	{ @Sym bracelefttp	{ @Sym braceleftmid
{ @Sym braceleftbt	@Sym braceex	} @Sym angleright	∫ @Sym integral
∫ @Sym integraltp	@Sym integralex	∫ @Sym integralbt) @Sym parenrighttp
@Sym parenrightex) @Sym parenrightbt] @Sym bracketrighttp	@Sym bracketrightex
] @Sym bracketrightbt] @Sym bracerighttp	} @Sym bracerightmid] @Sym bracerightbt

There is only one Symbol font; it does not come in bold or italic faces like the other fonts. Typing @B @Sym alpha is therefore useless, and anyway there is no bold α character in any font distributed with Lout.

Next there are the dingbats. Here they are with their (regrettably meaningless) names:¹

@Ding	Dingbat	@Ding	Dingbat	@Ding	Dingbat	@Ding	Dingbat	@Ding	Dingbat	@Ding	Dingbat
a1		a2		a202		a3		a4		a5	
a119		a118		a117		a11		a12		a13	
a14		a15		a16		a105		a17		a18	
a19		a20		a21		a22		a23		a24	
a25		a26		a27		a28		a6		a7	
a8		a9		a10		a29		a30		a31	
a32		a33		a34		a35		a36		a37	
a38		a39		a40		a41		a42		a43	
a44		a45		a46		a47		a48		a49	
a50		a51		a52		a54		a55		a56	
a57		a58		a59		a60		a61		a62	
a63		a64		a65		a66		a67		a68	
a69		a70		a71		a72		a73		a74	
a203		a75		a204		a76		a77		a78	
a79		a81		a82		a83		a84		a97	
a98		a99		a100		a101		a102		a103	
a104		a106		a107		a108		a112		a111	
a110		a109		a120		a121		a122		a123	
a124		a125		a126		a127		a128		a129	
a130		a131		a132		a133		a134		a135	
a136		a137		a138		a139		a140		a141	
a142		a143		a144		a145		a146		a147	
a148		a149		a150		a151		a152		a153	
a154		a155		a156		a157		a158		a159	
a160		a161		a163		a164		a196		a165	
a192		a166		a167		a168		a169		a170	
a171		a172		a173		a162		a174		a175	
a176		a177		a178		a179		a193		a180	
a199		a181		a200		a182		a201		a183	
a184		a197		a185		a194		a198		a186	
a195		a187		a188		a189		a190		a191	

¹If you see only conventional characters in this table, the problem is that your viewer does not have access to the Dingbats font. The author's viewer has this problem, for example, but his printer doesn't.

The easiest way to get a dingbat is to write, for example,

```
@Ding a123
```

which produces the dingbat with the given name from the table above. This is just a shorthand for

```
{ Dingbats Base } @Font { @Char a123 }
```

In other words, dingbats are just another font.

Finally we have a few more characters that you get with the @Char symbol, although they aren't ISO-LATIN-1 characters.

,	@Char quotesinglbase	„	@Char quotedblbase	...	@Char ellipsis	Œ	@Char OE
œ	@Char oe	“	@Char quotedblleft	”	@Char quotedblright	fi	@Char fi
fl	@Char fl	–	@Char endash	—	@Char emdash	•	@Char bullet
†	@Char dagger	‡	@Char daggerdbl	f	@Char florin	/	@Char fraction

Most of these characters are also in the list of ‘characters important enough to deserve their own symbols’ given above.

1.5. The empty object

It is possible to produce examples in which an object is clearly missing:

```
{ @I }
```

The @I symbol is supposed to italicize the following object, but in this example there isn't one. A more plausible example is

```
@PP
@PP
```

There are supposed to be paragraph objects between paragraph symbols, but here there aren't.

Wherever an object is clearly missing, Lout inserts an *empty object*, which is a rectangle of size zero by zero that prints as nothing. Here are two other ways to get an empty object:

```
{ } ""
```

Braces always enclose an object, so Lout is obliged to insert an empty object between them; the two double quotes make a word with no characters in it, which is taken to be an empty object.

1.6. Fonts and font sizes

A *font* is a collection of characters that may be printed. For example, here is the Times Roman font:

!"#\$%&'()*+,-./0123456789:;<=>?@[\\]^_`
ABCDEFGHIJKLMNOPQRSTUVWXYZ
abcdefghijklmnopqrstuvwxyz
{ } ~ ¡ ¢ £ ¤ ¥ ¦ § ¨ © ª « ¬ ® ¯ ° ± ² ³ ´ µ ¶ · ¸ ¹ º » ¼ ½ ¾ ¿
À Á Â Ã Ä Å Æ Ç È É Ê Ë Ì Í Î Ï Ð Ñ Ò Ó Ô Õ Ö × Ø Ù Ú Û Ü Ý Þ
ß à á â ã ä å æ ç è é ê ë ì í î ï ð ñ ò ó ô õ ö ÷ ø ù ú û ý þ

and here is the Times Italic font:

!"#\$%&'()+,-./0123456789:;<=>?@[\\]^_`
ABCDEFGHIJKLMNOPQRSTUVWXYZ
abcdefghijklmnopqrstuvwxyz
{ } ~ ¡ ¢ £ ¤ ¥ ¦ § ¨ © ª « ¬ ® ¯ ° ± ² ³ ´ µ ¶ · ¸ ¹ º » ¼ ½ ¾ ¿
À Á Â Ã Ä Å Æ Ç È É Ê Ë Ì Í Î Ï Ð Ñ Ò Ó Ô Õ Ö × Ø Ù Ú Û Ü Ý Þ
ß à á â ã ä å æ ç è é ê ë ì í î ï ð ñ ò ó ô õ ö ÷ ø ù ú û ý þ*

As their names imply, these two fonts belong to the *Times family*, a collection of fonts designed to go well together. Every font has a *family name*, such as Times, Helvetica, or Courier, and a *face name*, such as Roman or Italic. To find out how to get the unusual characters, see Section 1.4.

Documents look best when they use just one font family, so the most common need is to change to a different face within the current family. We have already seen @I, which changes to the Italic face of the current family; there are six such symbols:

- @B { Hello World } **Hello World**
- @I { Hello World } *Hello World*
- @BI { Hello World } ***Hello World***
- @II { Hello World } *HELLO WORLD*
- @S { Hello World } HELLO WORLD
- @R { Hello World } Hello World

The symbols' names stand for Bold, Italic, Bold-Italic, Italic-Italic (see below), Small capitals, and Roman. It is conventional to use Bold for headings; Italic for emphasis, terms being defined, and subsidiary headings; and Roman for the rest. Small capitals are not really a different font; they are made on demand from the current font. So you can write, for example,

@I @S { Hello World }

and get *HELLO WORLD*. You can change the size of small capitals using the @Font or @InitialFont symbols, as described below.

The @R symbol is almost unnecessary, since the document as a whole is set in a Roman face; but it is occasionally useful:

@I { An Italic sentence with one @R Roman word }

produces

An Italic sentence with one Roman word

This illustrates the general principle that the effect of a font symbol on the following object is subject to font symbols within that object.

When part of a title is to be set in italic font, neither @I nor @BI is suitable because the part should appear in bold italics in the title itself, but in ordinary italics in running headers and the table of contents. The @II symbol is the one for this situation: it produces bold italics when the current font is bold, and ordinary italics otherwise.

Changing families is a little more complicated. Here is the complete list of font families and their faces available with Bassor Lout Version 3:

AvantGarde	Base Slope Bold BoldSlope BoldObl Book BookOblique CondBold CondBook CondDemi CondMedium Demi DemiOblique ExtraLight ExtraLightObl Medium MediumObl
Bookman	Base Slope Bold BoldSlope BoldItalic Demi Demitalic Light LightItalic Medium MediumItalic
Chancery	Base Slope Bold BoldSlope Roman Bold Italic Light Demi LightItalic MediumItalic
Courier	Base Slope Bold BoldSlope BoldOblique Oblique
Helvetica	Base Slope Bold BoldSlope Black BlackOblique BoldOblique Compressed Cond CondBlack CondBlackObl CondBold CondBoldObl CondLight CondLightObl CondOblique ExtraCompressed Light LightOblique Narrow NarrowBold NarrowBoldObl NarrowObl Oblique UltraCompressed
Schoolbook	Base Slope Bold BoldSlope BoldItalic Italic Roman
Palatino	Base Slope Bold BoldSlope BoldItalic BoldItalicOsF BoldOsF Italic ItalicOsF Roman SC
Symbol	Base Slope Bold BoldSlope
Times	Base Slope Bold BoldSlope BoldItalic BoldItalicOsF BoldSC ExtraBold Italic ItalicOsF Roman RomanSC Semibold SemiboldItalic
Dingbats	Base Slope Bold BoldSlope

Lout understands all these fonts, but your printing device may not. Times, Helvetica, Courier, and Symbol at least seem to be ubiquitous, although not in every face. These fonts work only with languages that use the Latin1 character set; consult Section 1.14 for more information about this. It is not difficult for a Lout expert to extend this list [5].

It is a convention in Lout that every font family should at least contain faces called **Base**, **Slope**, **Bold**, and **BoldSlope**, and these faces are what the @R, @I, @B, and @BI symbols give you. But this convention is something of a fiction for two reasons. First, some font families don't have faces that could reasonably be described as bold or whatever. In particular, the Symbol family contains just one face, and all four conventional face names produce that face. Second, the four conventional face names are not names that typographers actually use, **Bold** excepted. **Slope** produces an italic face in some families and an oblique one in others. As the table shows, the true names are available if you want to use them, but it is very convenient to have a **Slope** face that is guaranteed to exist no matter which family is used.

The @Font symbol changes the font of the following object. For example,

```
{ Helvetica Slope } @Font { Hello World }
```

produces

Hello World

When changing to a different family, a face name must follow the family name; but when changing face within a family, just the face name is sufficient.

To make the characters larger or smaller, you need to change the *font size*, which can also be done with the @Font symbol. Font sizes are traditionally measured in *points*: there are 72 points to one inch, and the most common font sizes are 12 point and 10 point. However, as Section 1.2 explains in detail, any length including fractional lengths is acceptable:

```
24p @Font { Hello World }
```

changes to 24 point size, producing

Hello World

It is also possible to specify a font size relative to the current size: +2p means two points larger, -2p means two points smaller, and 1.5f means 1.5 times the current font size.

If you switch font sizes in the middle of a line, as in

Here's a 20p @Font big word

you will discover one of Lout's obscure secrets:

Here's a **big** word

Adjacent letters are aligned vertically through their middles, not through the baseline, causing this awkward alignment. This was done because it makes equation formatting easy, and examples like the above look poor anyway. However, if you want to do this and so require alignment through the baseline, you can get it, with the baselinemark option to the @Font symbol:

```
baselinemark @Font { Here's a 20p @Font big word }
```

which produces

Here's a **big** word

If you want it this way throughout your document, you can put baselinemark in your initial font (see below). Lout's equation formatter contains the opposite option, which is xheight2mark @Font { ... } (which aligns through a point half the height of an x character) so you won't disrupt equation formatting if you do this, although if you put an equation inside a paragraph, its axis will be aligned with the baseline of the adjacent words.

There is an @F symbol which switches to a fixed width font family:

```
@F { Hello world }
```

produces the equivalent of { Courier Base -1p } @Font ..., like this:

```
Hello world
```

The -1p is included to compensate for the relatively large appearance of the Courier font.

The document as a whole will be set in Times Base 12p. To change this you need to change the @InitialFont option, for example to

```
@InitialFont { Helvetica Base 10p }
```

to get Helvetica 10 point. You must give all three parts in @InitialFont: family, face, size. If you are using your own setup file, as explained in Section 4.1, you can find the @InitialFont option there. If not, you can set it at the beginning of your document as explained in Section 3.1.

The @InitialFont option is also a good place to set the size of small capitals if you don't like the default size that Lout gives you:

```
@InitialFont { Helvetica Base 10p setsmallcaps 0.9 }
```

In this example we're asking for small capitals to have size 0.9 times the height of ordinary capitals. The number following setsmallcaps is a ratio, not a length, so it carries no unit of measurement. You can put setsmallcaps in an ordinary @Font symbol too, if you like. For example,

```
{ setsmallcaps 0.9 } @Font @S { Hello, world }
```

has result

```
HELLO, WORLD
```

However for consistency most people would use setsmallcaps only in @InitialFont, if at all.

There are two features that make fonts look better on the page. *Ligatures* are pairs of letters run together; the most common ligatures are 'fi' and 'fl.' *Kerning* is moving adjacent letters closer together, for example in 'VA.' Lout considers ligatures and kerning to be integral parts of each font; you can prevent them from happening only by enclosing one of the letters in a @OneCol symbol, as in @OneCol { V }A. Alternatively, to turn off ligatures you can write

```
nolig @Font { ... }
```

and then ligatures will not be used within the object following @Font. Should you ever need to turn ligatures on within a region where they are turned off, use lig @Font.

1.7. Headings

The @Heading symbol makes the following object into a heading. Actually, all it does is change the font, so if you want a centred heading you have to display it as well:

```
@Display @Heading { A Centred Heading }
```

```
Following text
```

If you want a left-justified heading, use `@LeftDisplay` instead of `@Display`. Alternatively, you can use no display symbol at all, but then you will need paragraph symbols before and after:

```
@DP
@Heading { A Left-Justified Heading }
@PP
Following text
```

The font used is **Bold** in the current family, although you can change this by changing the `@HeadingFont` option in the setup file (Section 4.1).

In complex documents, large-scale structure symbols (Section 2.7) are usually more appropriate than the `@Heading` symbol.

1.8. Starting a new line, paragraph, or page

The usual way to start a new paragraph is with the `@PP` ‘plain paragraph’ symbol. It produces a small vertical space and indents the first line of the new paragraph. Some document formatting systems interpret a blank line as a request to start a new paragraph. This is not the case with Lout: a blank line is two line-endings, equivalent to two spaces.

The `@LP` ‘left paragraph’ symbol produces the same vertical space as `@PP`, but omits the indent. The `@LLP` ‘left line paragraph’ symbol starts a new paragraph using the usual inter-line spacing and no indent, or in other words it starts a new line. If you are using it to create single lines, you need the lines paragraph breaking style instead (Section 1.9).

The `@DP` ‘display paragraph’ symbol produces a somewhat larger vertical space, equal to the amount used before and after displays (Section 2.1), with no indent. To get even more space, use `@DP` repeatedly. Another symbol, `@LOP`, leaves a paragraph break the size of the gap left outside (that is, before and after) lists (Section 2.2). This is usually equal to `@DP`.

The `@NP` ‘new page’ symbol causes the following paragraph to begin on a new page or column. Of course, Lout starts a new page or column automatically when the old one is full, so `@NP` is needed only rarely.

To make each section begin on a new page you must set the `@SectionGap` setup file option (Section 2.7). To make one particular section start on a new page or column, place `@NP` within the previous section, at the end. Placing `@NP` between sections will not work.

Occasionally Lout will start a new page or column directly after a heading, which looks very poor. The obvious answer is to place an `@NP` just before the heading, but when the document is later revised and the heading no longer falls near the page or column ending, this `@NP` will have to be taken away again. A better answer is to precede the heading with a `@CNP` ‘conditional new page’ symbol, which checks whether enough space remains in the page or column for a heading and at least two lines of text. If so, `@CNP` does nothing; if not, `@CNP` causes a new page or column to be begun, like `@NP`. The recommended arrangement is

```
@DP
@CNP
@Heading { A Heading }
@PP
First paragraph of next part ...
```

The @CNP symbol should be preceded by either @DP or @LP, preferably @DP, and this determines the amount of space when the @NP action does not occur.

The ultimate answer to the conditional new page problem is to recognise that the heading is the beginning of a new section of the document, and to use a large-scale structure symbol like @Section (Section 2.7). Conditional new page is just one of many services provided automatically by these symbols.

Some people do not like to see the first line of a paragraph alone at the bottom of a page, or the last line of a paragraph alone at the top (these blemishes are sometimes called widows and orphans). You can instruct Lout not to allow these; see the next section for details.

You can modify the effect of the paragraph symbols by changing options in the setup file. For general information about setup files and their options, consult Section 4.1; here we just explain how the relevant options work. The options and their default values are

```
@ParaGap { 1.30vx }
@ParaIndent { 2.00f }
@DisplayGap { 1.00v }
```

The values are lengths (Section 1.2), except that for reasons beyond our scope @ParaGap must be a length with an x appended, as shown. The @ParaGap option determines how much vertical space will be inserted by @PP and @LP. The default value, 1.30vx, is 30% more than the normal inter-line spacing; to get no extra spacing, change it to 1.00vx. The @ParaIndent option determines the width of the indent produced by @PP, and its default value is twice the current font size. The @DisplayGap option determines the amount of vertical space inserted by @DP, as well as the vertical space before and after displays.

1.9. Paragraph breaking

Paragraph breaking is the process of inserting line breaks into paragraphs at places appropriate to the column width. Lout works out suitable column widths and performs paragraph breaking automatically, finding an ‘optimal’ break with the method used by the T_EX system. It offers ten styles of paragraph breaking, which we will explore with the aid of this example:

```
It is a truth universally
acknowledged, that a single man
in possession of a good fortune,
must be in want of a wife.
```

Changing the paragraph breaking style is similar to changing the font, colour, or language, and is done using the @Break symbol:

```
ragged @Break ...
```

This example causes every paragraph in the following object to be broken using the ragged style, of which more below.

The first two of the ten styles perform *line adjustment*, which means that they enlarge the spaces between the objects making up each line so as to fill the lines completely:

adjust @Break ...	It is a truth universally acknowledged, that a single man in possession of a good fortune, must be in want of a wife.
-------------------	---

outdent @Break ...	It is a truth universally acknowledged, that a single man in possession of a good fortune, must be in want of a wife.
--------------------	---

The adjust style is frequently used, so it has been chosen as the default style. Outdenting adds a small space at the start of each line except the first, and is much less common.

The next four styles do not adjust lines, leaving the paragraph *ragged*:

ragged @Break ...	It is a truth universally acknowledged, that a single man in possession of a good fortune, must be in want of a wife.
-------------------	---

cragged @Break ...	It is a truth universally acknowledged, that a single man in possession of a good fortune, must be in want of a wife.
--------------------	---

rragged @Break ...	It is a truth universally acknowledged, that a single man in possession of a good fortune, must be in want of a wife.
--------------------	---

oragged @Break ...	It is a truth universally acknowledged, that a single man in possession of a good fortune, must be in want of a wife.
--------------------	---

The paragraph is broken in the same places as adjust breaks it, but the resulting lines are left-justified, centred, or right-justified with respect to each other, rather than adjusted; oragged is like outdent except the resulting lines are not adjusted.

If you have a few words that must be kept together on one line, the recommended way is to separate them by an ~ symbol:

According to Prof.~Jones, the effect of ...

It's best not to bother about this until you actually get a bad line break, since chances are good that the words will fall on one line anyway.

The last four styles differ from the first six in breaking the paragraph at the points where it is broken in the original input:

lines @Break ...

It is a truth universally
acknowledged, that a single man
in possession of a good fortune,
must be in want of a wife.

clines @Break ...

It is a truth universally
acknowledged, that a single man
in possession of a good fortune,
must be in want of a wife.

rlines @Break ...

It is a truth universally
acknowledged, that a single man
in possession of a good fortune,
must be in want of a wife.

olines @Break ...

It is a truth universally
acknowledged, that a single man
in possession of a good fortune,
must be in want of a wife.

The lines are left-justified, centred, right-justified, or outdented with respect to each other in the same way as for the ragged styles.

When using the lines style, there are some fine points concerning the proper use of white space. Consider this example:

```
@IndentedDisplay lines @Break @I {
Teach me to hear Mermaidess singing,
Or to keep off envies stinging,
    And finde
    What winde
Serves to'advance an honest minde.
}
```

The result is the indented display

*Teach me to hear Mermaidess singing,
Or to keep off envies stinging,
 And finde
 What winde
Serves to'advance an honest minde.*

This style is the only one for which it is useful to indent individual lines in the input; as the result shows, such indents will be respected. However, Lout's rule that only white space separating objects affects the result (Section 1.3) still holds, which means that indenting the first line is not effective:

```
@IndentedDisplay lines @Break @I {
  And finde
  What winde
  Serves to'advance an honest minde.
}
```

produces

```
And finde
  What winde
  Serves to'advance an honest minde.
```

This may seem awkward at first, but actually it is extremely convenient because you don't have to worry about whether the first line of the paragraph should appear on a new line as above, or immediately after the opening brace: space at that point does not separate two objects, so it has no effect. The indent can be obtained by starting the first line with an empty object (Section 1.5):

```
@IndentedDisplay lines @Break @I {
 {} And finde
  What winde
  Serves to'advance an honest minde.
}
```

The result is

```
And finde
  What winde
  Serves to'advance an honest minde.
```

as desired.

When using lines, clines, rlines, and olines @Break, blank lines are respected and ordinarily appear at their full height. However, it often looks better to give somewhat less than this to blank lines. For this there is the blanklinescale option to @Break:

```
@IndentedDisplay { lines blanklinescale 0.6 } @Break @I {
Go, and catch a falling star,
  Get with child a mandrake root,
Tell me, where all past years are,
  Or who cleft the Devil's foot,
Teach me to hear Mermaides singing,
Or to keep off envies stinging,
  And finde
  What winde
Serves to'advance an honest minde.
```

```
If thou be'st born to strange sights,
  Things invisible to see,
Ride ten thousand days and nights,
  Till age snow white hairs on thee,
Thou, when thou return'st, wilt tell me
All strange wonders that befell thee,
  And swear
  No where
Lives a woman true, and fair.
}
```

As shown, `blanklinescale` may appear at any point in the object to the left of `@Break`, followed by a number indicating how much to scale the usual height of a blank line by. The object to the left of `@Break` has to be enclosed in braces as shown, to ensure that its extent is clear. The result is

```
Go, and catch a falling star,
  Get with child a mandrake root,
Tell me, where all past years are,
  Or who cleft the Devil's foot,
Teach me to hear Mermaides singing,
Or to keep off envies stinging,
  And finde
  What winde
Serves to'advance an honest minde.

If thou be'st born to strange sights,
  Things invisible to see,
Ride ten thousand days and nights,
  Till age snow white hairs on thee,
Thou, when thou return'st, wilt tell me
All strange wonders that befell thee,
  And swear
  No where
Lives a woman true, and fair.
```

in which the verses are separated by considerably less than a full blank line; instead of a

baseline-to-baseline gap of twice the interline space, as usual, the gap here is only 1.6 times the interline space. Two blank lines would give 2.2 times the interline space, and so on. There is no unit of measurement associated with `blanklinescale`, because it is a scale factor, not a length.

To set the entire document in a paragraph breaking style other than `adjust`, you need to change the `@InitialBreak` option, as explained at the end of Section 1.10.

Some people don't like to see the first line of a paragraph alone at the foot of a page or column (the rest appearing on the next page). You can instruct Lout not to allow this with

```
unbreakablefirst @Break ...
```

meaning that the first line cannot be broken off from the rest of the paragraph. Similarly,

```
unbreakablelast @Break ...
```

instructs Lout to prevent the last line of a paragraph from appearing alone at the top of a page or column. These features would probably be invoked in the `@InitialBreak` option, like this:

```
@InitialBreak { unbreakablefirst unbreakablelast hyphen adjust 1.2fx }
```

You can turn them off with `breakablefirst @Break` and `breakablelast @Break`. In both cases Lout makes it happen by breaking at the previous place, either between paragraphs or two lines from the end of a paragraph. Both features are compatible with Lout's `@OptimizePages` option, which optimizes the overall page layout subject to these requirements.

1.10. Line spacing

The `@Break` symbol also controls the amount of space placed between the lines of paragraphs. This distance is best given using the `v` unit of measurement: `1v` is the current line separation (see Section 1.2 for a description of lengths in general). For example,

```
2vx @Break ...
```

produces double spacing in the paragraphs of the following object, and

```
0.9vx @Break ...
```

produces cramped spacing, which can be useful in large tables that don't quite fit on one page. The `x` following the `v` is required, but its meaning is beyond our scope [5].

To set the entire document in a different line spacing from the default, you need to change the `@InitialBreak` option. If you are using your own setup file (Section 4.1), change it there. If not, you can change it at the beginning of your document, as described in Section 3.1.

The default value of the `@InitialBreak` option produces the `adjust` paragraph breaking style with a line spacing of 1.20 times the current (that is, the initial) font size, and hyphenation on:

```
@InitialBreak { adjust 1.20fx hyphen }
```

To get double spacing, change it to

```
@InitialBreak { adjust 2.40fx hyphen }
```

To get ragged paragraphs with hyphenation off, change it to

```
@InitialBreak { ragged 1.20fx nohyphen }
```

and so on. It is a good idea to define the initial line spacing using the *f* unit, since then if you change the initial font size the line spacing will change with it. However, any length (Section 1.2) with an *x* appended will do: 14px for 14 point, 0.5cx for 0.5 centimetres, etc. Don't use the *v* unit though, because it refers to some *previous* line spacing, whereas here we are defining the line spacing for the first time.

1.11. Hyphenation

The `@Break` symbol also controls hyphenation: `hyphen @Break` turns it on, `nohyphen @Break` turns it off. For example, ragged breaking is often done without hyphenation:

```
@IndentedDisplay { ragged nohyphen } @Break {
This little paragraph will appear with
ragged ends to its lines.
}
```

Lout's method of choosing hyphenation points is copied from the \TeX system, except that Lout will never place a hyphen within a sequence of characters that form a ligature (fl and fi are the most common ligatures).

Hyphenation usually works well by itself; you should never need to interfere with its ideas of what to do. However, if you do want to tell Lout where you think a hyphen could be inserted, you can use the `&-` symbol:

```
after&-math
```

This both allows hyphenation at the point marked and prevents it in the adjacent word fragments. If `&-` occurs directly after a hyphen or slash character, hyphenation will be permitted but no extra hyphen will be inserted.

To prevent hyphenation of a word, enclose the word in a `@OneCol` symbol. To turn hyphenation off throughout the document, you need to set the `@InitialBreak` option to `nohyphen`, as described at the end of Section 1.10.

1.12. Margin kerning

The `@Break` symbol offers a variant of ordinary paragraph breaking called *margin kerning*, in which small characters that happen to end up at the start or end of a line protrude slightly into the margin. This is said to make documents look better, particularly in narrow columns. For example,

```
2i @Wide marginkerning @Break {
This is a test, just a little test, of
margin kerning. It should kern small
characters at the margins.
```

}

produces

This is a test, just a little test,
of margin kerning. It should
kern small characters at the
margins.

in which the comma at the end of the first line protrudes. (For the @Wide symbol, which produces a two-inch column here, see Section 8.10.)

As with most @Break options, you probably want this in your @InitialBreak option, described in Section 1.9, if you use it at all. By default there is no margin kerning. To turn it off in a context where it is on, use nomarginkerning @Break.

1.13. Underlining

The @Underline symbol underlines the following object:

This little paragraph of text will have
@Underline { three underlined words } in it.

produces

This little paragraph of
text will have three un-
derlined words in it.

The underlining is continuous unless a line break intervenes. You can't use this symbol to underline an arbitrary object: it is carefully designed to produce high-quality underlining of single words and parts of paragraphs, and it works only for those objects.

Each font contains information about how words in that font should be underlined: how far below the baseline the line should be drawn, and how thick. The @Underline symbol uses this information; the font it bases its underlining on is the font of the first object underlined if it is a word, or else the font of the enclosing paragraph.

The underline produced by @Underline will have the same colour as whatever is being underlined. If you want a different colour, you need the @ColouredUnderline or equivalently @ColoredUnderline symbol, which takes a colour on the left as well as the thing to be underlined on the right:

This little paragraph of text will have
blue @ColouredUnderline { three underlined words } in it.

produces

This little paragraph of
text will have three un-
derlined words in it.

The colours available are as for the @Colour symbol from Section 8.1.

There is no way to set a default value for the colour of a coloured underline, but you can make it easy to get an underline of a specific colour, by placing a definition at the start of your document, like this:

```
import @BasicSetup
def @MustCheck right x { blue @ColouredUnderline x }
```

This allows you to type @MustCheck instead of blue @ColouredUnderline. Definitions are explained in general in Section 2.13.

1.14. Languages other than English

When part of a document is written in a language other than English, Lout should be informed of this using the @Language symbol:

```
... the garter, he said: French @Language { 'Honi soit qui mal y
pense' }, and this saying ...
```

Changing language is quite analogous to changing font using the @Font symbol.

At the time of writing, the following languages were available:

Croatian Hrvatski	Italian Italiano it
Czech Cesky Cestina cs	Norwegian Norsk no
Danish Dansk da	Polish Polski pl
Dutch Nederlands nl	Portuguese Português pt
English en	Programming
EnglishUK en-GB	Russian ru
Esperanto eo	Slovak Slovensky Slovencina
Finnish Suomi fi	Slovenian Slovenia Slovenija sl
French Francais Français fr	Spanish Español es
German Deutsch de	Swedish Svenska sv
Hungarian Magyar hu	UpperSorbian hornjoserbsce serbsce

File include/langdefs in the distribution always has the exact list of known languages. As shown, most languages have alternative names, all equally acceptable to the @Language symbol. EnglishUK differs from English only by applying hyphenation rules said to be more appropriate for British English; Programming is for programming languages and is used by the symbols of Chapter 12.

Since accented characters (Section 1.4) are always available irrespective of the language, at first sight it might seem that there is no need to bother informing Lout what language you are writing in. However, words are hyphenated differently depending on the language, and some symbols have different results in different languages. For example,

```
Danish @Language @Date
```

produces

24. september, 2009

and the alphabetic list symbols of Section 2.2 also vary with the current language. So it's worth doing for the sake of knowing that non-English parts will appear as they should.

If your entire document is in a language other than English, you need to change the `@InitialLanguage` option:

```
@InitialLanguage { Deutsch }
```

If you are using your own setup file (Section 4.1), you can change it there. If not, you can change it at the start of your document, as explained in Section 3.1.

Czech, Polish, and Slovenian (at least) use the Latin2 character set, and users of these languages have to place

```
@SysInclude { latin2 }
```

at the start of their documents in order to get access to the Latin2 versions of the fonts.¹ These have family names such as TimesCE, CourierCE, HelveticaCE, and so on (CE standing for Central European), to distinguish them from the same fonts encoded in Latin1. The face names are unchanged. A typical Latin2 document would therefore start off like this:

```
@SysInclude { latin2 }
@SysInclude { doc }
@Document
  @InitialLanguage { Polish }
  @InitialFont { TimesCE Base 12p }
//
```

Depending on the document type there may be a few other font-setting options in the setup file that need to be changed; in fact, it might be best to produce your own setup file in this case, replacing `doc`, with the changed options in it. See Section 4.1 for how to do this. You could even start your setup file off with `@SysInclude { latin2 }` to avoid the trouble of typing it at the top of every document. Consult database file `latin2.ld` in the standard database directory for a complete list of Latin2 fonts.

Russian uses Cyrillic characters. In principle, users of Russian have to place

```
@SysInclude { russian }
```

at the very start of their documents in order to get access to Cyrillic fonts. However no such fonts are distributed with the current version of Lout, so this line does nothing at present. Other left-to-right languages are easily added, so consult the author if your language is not listed.

¹Prior to Version 3.21 of Lout, some accented characters were missing from these Latin2 fonts, but this deficiency has now been corrected by getting Lout to generate output for these characters which prints their base letter and accent separately.

1.15. The current date and time

The @Date and @Time symbols produce the current date and time:

It is now @Time on @Date.

produces something like

It is now 11.12 a.m. on 24 September, 2009.

The result depends on the current language.

Both symbols have a @Format option that changes the format of the result:

```
@Date @Format { @DayNum"/"@MonthNum"/"@ShortYear }
```

The result is the @Format option with the symbols replaced by the appropriate values:

24/9/09

The / characters have been enclosed in double quotes for the usual reason (Section 1.4).

Here is the full list of symbols that you can use within both @Format options:

@Year	The year, e.g. 1994
@ShortYear	The last two digits of the year, e.g. 94
@Month	The month, e.g. December
@ShortMonth	The month abbreviated, e.g. Dec
@MonthNum	The number of the month, between 1 and 12
@Day	The day of the week, e.g. Saturday
@ShortDay	The day abbreviated, e.g. Sat
@DayNum	The day of the month, between 1 and 31
@MeriDiem	a.m. or p.m.
@ShortMeriDiem	am or pm
@Hour	The hour, between 00 and 23
@ShortHour	The hour, between 0 and 23
@TwelveHour	The hour, between 1 and 12
@Minute	The minute, between 00 and 59
@Second	The second, almost always between 00 and 59

The default format for @Date in English is

```
@Date @Format { @DayNum @Month, @Year }
```

and the default format for @Time in English is

```
@Time @Format { @TwelveHour.@Minute @MeriDiem }
```

Both default formats depend on the current language, and so do @Month, @ShortMonth, @Day, and @ShortDay, @MeriDiem and @ShortMeriDiem.

1.16. Superscripts and subscripts

There are @Sup and @Sub symbols for producing superscripts and subscripts:

```
2 @Sup nd
```

produces

2nd

and the @Sub symbol works in a similar way. These symbols are probably never required in English language text, since the only uses for them are in footnotes, which produce the superscript automatically, and equations, which have their own versions of these symbols. Both symbols have a gap option which determines the vertical spacing.

1.17. Verbatim and piped text

The @Verbatim symbol¹ prints the following object exactly as it appears in the input file. All special meanings for characters, symbols, etc. are turned off; there is one result line for each input line. For example,

```
@IndentedDisplay @Verbatim {
A line of "verbatim" text
Another line, with a \ character
}
```

has result

```
A line of "verbatim" text
Another line, with a \ character
```

Use @F @Verbatim { ... } to get the result in a fixed-width font.

If the verbatim text contains { or } characters, then they should either be balanced or else you need to use the alternative form

```
@Verbatim @Begin
...
@end @Verbatim
```

so that there is no doubt about where the verbatim text ends. Although we have said that there are no special meanings, there is one exception to this rule: @Include and @SysInclude commands are recognized, allowing all or part of the verbatim text to come from some other file. Braces do not have to be balanced in that file.

Occasionally the first line of some verbatim text begins with some spaces that have to be preserved. This is a problem for @Verbatim because it ignores all white spaces following the opening brace and all white spaces preceding the closing brace. However, the alternative

¹Prior to Version 3.13 the @Verbatim symbol was restricted to Unix systems only. This restriction no longer applies to @Verbatim and @RawVerbatim, but it does apply to @Pipe, @PipeVerbatim, and @PipeRawVerbatim.

`@RawVerbatim` symbol stops ignoring white spaces at the opening as soon as a newline character is reached; in other words, it will preserve all white spaces following the first newline.

The `@Pipe` symbol (available on Unix-style systems only) may be used to pipe some text through a Unix command. For example,

```
@ID lines @Break "sort" @Pipe {
Gaskell, Elizabeth
Lawrence, D. H.
Austen, Jane
Dickens, Charles
}
```

will cause the object between braces following `@Pipe` to be piped without interpretation through the Unix `sort` command; its output is the result of the `@Pipe` command, here made into a display preserving the line breaks in the output. The final result will be the four authors, one per line, in alphabetical order. We can't show this result to you because that would make this manual not compilable on non-Unix systems.

The double quotes around `sort` are not necessary in this example, but may be in more complex ones. For example, one can see just the first few lines of the sorted result using

```
"sort | head" @Pipe ...
```

and here the quotes are necessary because `|` is one of the special characters that need quoting, according to Section 1.4. The quotes also serve to group the command into a single Lout object.

Some Unix commands don't need any input, and then the object following `@Pipe` may be empty. For example,

```
"ls" @Pipe {}
```

will list the files of the current directory.

Any Lout symbols in the result of the `@Pipe` symbol, such as `@PP`, `@Box`, and so on, will be interpreted in the usual way. This is convenient because it allows you to write your own Unix commands that include Lout symbols in their output. However, sometimes it is preferable if the output is treated verbatim. For example,

```
"pwd" @Pipe {}
```

attempts to print the current working directory, but this will not come out well because the output contains `/` symbols, which Lout will then attempt to interpret as Lout symbols. To avoid this problem, use `@PipeVerbatim` instead of `@Pipe`:

```
"pwd" @PipeVerbatim {}
```

This causes the output of the command to be enclosed in `@Verbatim @Begin` and `@End @Verbatim`. There is also a `@PipeRawVerbatim` symbol which encloses the output in `@RawVerbatim` rather than the ordinary `@Verbatim`.

1.18. Drop capitals

There are two symbols for producing drop capitals, `@DropCapTwo` and `@DropCapThree`. Place the capital to be dropped just before the symbol, and the rest of the paragraph after it:

```
I @DropCapTwo {
  t is a truth universally acknowledged, that a single man
  in possession of a good fortune, must be in want of a wife.
}
```

produces the object

It is a truth universally acknowledged, that
a single man in possession of a good
fortune, must be in want of a wife.

`@DropCapThree` is the same except that the capital is larger and spreads over three lines.

Because Lout occasionally gets the height of the enlarged capital slightly wrong, there is a `height` option which allows you to change the height if you need to:

```
H @DropCapTwo height { 1.5v }
{
  ...
}
```

This shows the default value for the height of the capital in `@DropCapTwo`: 1.5 times the current inter-line spacing. The default height in `@DropCapThree` is 2.5v.

These symbols produce an object which may appear anywhere in the usual way. A paragraph symbol will be needed after the paragraph. The paragraph breaking style of the body of the paragraph will be adjusted `nohyphen`; this cannot be changed at present.

1.19. Alternative conventions for white space

As Section 1.3 explains, when two objects are separated by one or more white space characters (spaces, tabs, and newlines), this same amount of white space will separate the two objects in the output.

Two other conventions for interpreting these white spaces have been used in other document formatting systems. Roughly, they are:

- `troff` Like Lout, except that at every point where a sentence ends at the end of an input line, add one extra space in the output.
- `TEX` Replace all sequences of two or more white spaces by one. Then, at every point where a sentence ends, whether or not it is at the end of a line, add one extra space in the output.

Lout offers these two alternative conventions by means of the `@InitialSpace` option. This is similar to the `@InitialFont` option described at the end of Section 1.6, in that you can set it at the

beginning of your document, like this:

```
@SysInclude { doc }
@Document
  @InitialSpace { lout }
//
@Text @Begin
...
@end @Text
```

or you can set it in the setup file. The above example shows the default value, `lout`, which produces Lout's usual spacing; the alternative values are `troff` and `tex`.

How to tell whether a sentence has ended is a vexed question. For the `troff` method, Lout looks for a word at the end of a line ending in one of `'`, `:`, `?`, or `!` optionally followed by either a right quote character or a right parenthesis. Actually, this depends on the current language (Section 1.14); the rule just given is for English, and other languages may differ.

The `tex` rule for where a sentence ends is slightly more complicated. Lout looks for a word, not necessarily at the end of an input line, which ends as described for `troff` but in addition has a lower-case letter preceding that.

In all cases you must use a paragraph symbol, such as `@PP` or `@LP`, to separate your paragraphs. The common convention of other systems, that a blank line marks a paragraph, is never true of Lout.

Whatever rule is adopted, there are occasional exceptions where you will have to indicate explicitly whether you want an ordinary space or a between-sentences space. For this there are two symbols, `~` (ordinary space) and `~~` (between-sentences space). For example,

```
Dr.~Kingston
```

will produce an ordinary space between the two words, even with `tex` which would otherwise consider that spot to be the end of a sentence. Spaces adjacent to these two symbols have no effect on the result. Please note however that `~` produces an unbreakable space (that is, one that will never be replaced by the end of a line) in contrast to just leaving a space, which is breakable.

Chapter 2. Adding Structure to Documents

2.1. Displays

The @Display symbol displays the following object in the centre of the page or column:

```
@Display @I { Invitation to Afternoon Tea }
```

has result

Invitation to Afternoon Tea

Space is inserted automatically above and below the display; no paragraph symbols are needed.

To make the display appear at the left margin instead of centred, use @LeftDisplay instead of @Display. To make an indented display, use @IndentedDisplay or @QuotedDisplay; the latter indents at the right margin as well as at the left. There are also @CentredDisplay and @CenteredDisplay symbols which centre the display just like @Display does, and @RightDisplay which right-justifies the display.

If you use displays frequently you might prefer abbreviated forms of their names. These are made from @ and the capital letters of the full name: @D, @LD, @ID, @QD, and @CD. Owing to a clash with the name of another symbol, @RightDisplay has no abbreviation.

Displays often need to be set using a different font, paragraph breaking style, and so on to the surrounding text. It's best to set out such displays like this:

```
@CentredDisplay @I clines @Break {  
  Invitation to Afternoon Tea  
  with  
  Mr. and Mrs. Gilbert Newington-Smith  
}
```

You can have as many of these symbols as you like, including specialized ones like @CurveBox and @Tbl. The only rule is that the display symbol must come first: @I @Display ... is wrong.

It's not a good idea to have one display immediately followed by another one, because there will be too much vertical space between them. Use a list instead (Section 2.2). Displays at the ends of paragraphs look awkward and are best avoided.

A display may come out partly on one page or column and partly on the next, if it has places where it obviously can be broken in two. For example, a display which is an ordinary paragraph of text might be broken in two between any two lines. To force a display to keep together on one page or column, use the @OneRow symbol like this: @Display @OneRow { ... }.

Other display symbols produce aligned and numbered displays, and raw displays (i.e. without vertical space). Although these can display any object as usual, in practice they are used

for mathematics, so they are described in Section 7.4.

Three setup file options control the appearance of displays. (For a general introduction to setup files and their options, consult Section 4.1.) Here they are with their default values:

```
@DisplayGap { 1.00v }
@DefaultIndent { 0.5rt }
@DisplayIndent { 2.00f }
```

`@DisplayGap` is the amount of vertical space inserted before and after displays, and may be any length (Section 1.2). The default value, `1.00v`, is equal to the current inter-line spacing.

`@DefaultIndent` is the indent produced by `@Display`; `0.5rt` produces centring, although why it does so is beyond our scope [5]. `@DisplayIndent` is the indent for `@IndentedDisplay`, and used at both margins by `@QuotedDisplay`. Its default value, `2.00f`, is twice the current font size.

2.2. Lists

The `@IndentedList` symbol introduces a sequence of items to be made into a displayed list:

```
preceding text
@IndentedList
@ListItem @l Emma
@ListItem @l { Mansfield Park }
@EndList
following text
```

After the initial `@IndentedList` symbol, each item is introduced by `@ListItem`, and the list ends with `@EndList`. The result here is

```
preceding text

    Emma

    Mansfield Park

following text
```

with space inserted automatically before, between, and after the items.

As the example shows, the `@IndentedList` symbol causes the items to be indented. Also available are `@LeftList`, `@QuotedList`, `@CentredList`, and `@CenteredList`, which format the items like the corresponding display symbols do. Other list symbols generate a *label* for each item. For example, `@NumberedList` causes the items to be numbered:

```
@Heading { Quiz }
@NumberedList
@ListItem { Which American statesman owned a two-storey clock? }
@ListItem { Which Yankee commander from the Civil War cut a
swathe of destruction through the State of Georgia? }
@EndList
```

has result

Quiz

1. Which American statesman owned a two-storey clock?
2. Which Yankee commander from the Civil War cut a swathe of destruction through the State of Georgia?

The generated labels are added at the left margin. Here is the full set of label-generating list symbols, showing the first label produced by each:

```
1. @NumberedList      (1) @ParenNumberedList
i. @RomanList         (i) @ParenRomanList
I. @UCRomanList       (I) @ParenUCRomanList
a. @AlphaList         (a) @ParenAlphaList
A. @UCAAlphaList      (A) @ParenUCAAlphaList
• @BulletList
* @StarList
– @DashList
```

The Roman numerals end at cc (200), but ordinary decimal numbers have no limit. The labels produced by the four alphabetical list symbols are determined by the current language; in English they start at a and end at z.

You may also supply your own labels using the @TaggedList symbol. Each item is introduced by @TagItem instead of @ListItem. Since such labels tend to be quite wide, there are @WideTaggedList and @VeryWideTaggedList symbols which leave extra space for them:

```
@WideTaggedList
@TagItem { 9 a.m. } { Breakfast in the Ipamena Lounge,
served with Irish coffee and fresh croissants. }
@TagItem { 10 a.m. } { Prof. A. Smith
speaks on 'The Wealth of Nations.' }
@EndList
```

Each @TagItem symbol is followed by the desired label between braces, and then the item proper. The label may be empty, but still its enclosing braces must be there. The result here is

```
9 a.m.   Breakfast in the Ipamena Lounge, served with Irish coffee and fresh croissants.
10 a.m.  Prof. A. Smith speaks on 'The Wealth of Nations.'
```

An alternative way to accommodate wide labels is the ‘drop item,’ which looks like this:

```
10 a.m.
    Prof. A. Smith speaks on ‘The Wealth of Nations.’
```

Individual items are dropped in this way by using `@DropTagItem` instead of `@TagItem`. There is also a `@DropListItem` symbol corresponding to `@ListItem`, but it is very rarely needed. Lout is not able to decide for itself whether a label is wide enough to require a drop item. Lout will refuse to skip to the next column or page between a drop tag and its item, preferring instead to move the drop tag to the next column or page.

Each list has a ‘raw’ version which omits the preceding space, and `@EndList` has a raw version which omits the following space. These are mainly used when an item is itself a list:

```
@ParenNumberedList
@ListItem {
    @RawParenRomanList
    @ListItem { MV Nominees,
hereinafter called the vendor, ... }
    @RawEndList
}
@EndList
```

produces

```
(1) (i) MV Nominees, hereinafter called the vendor, ...
```

If `@ParenRomanList` had been used instead of `@RawParenRomanList`, (1) and (i) would have appeared on different lines; or if `@EndList` had been used instead of `@RawEndList`, there would have been too much space following the list.

A list item may come out partly on one page or column and partly on the next, if it has places where it obviously can be broken in two. For example, a list item which is an ordinary paragraph of text might be broken in two between any two lines. To force a list item to keep together on one page or column, use the `@OneRow` symbol like this: `@ListItem @OneRow { ... }`.

Occasionally it is desirable to start a new page or column between two list items. This cannot be done by inserting `@NP` between them, because the space between two list items is a kind of no-man’s land where nothing is allowed to be. Instead, the `@ListNewPage` symbol is used: it is permitted only between two list items, and its effect is to make the following list item appear at the top of the next page or column. It may be used within any kind of list.

Another special list item is `@ListInterruptItem`. This prints its content without any numbering or formatting:

```
@NumberedList
@ListItem { This is the first list item. }
@ListInterruptItem { This is an interruption to the list. }
@ListItem { This is the second list item. }
@EndList
```

produces

1. This is the first list item.

This is an interruption to the list.

2. This is the second list item.

Although `@ListInterruptItem` is written like a list item, the result appears to be an interruption to the list. It may be used in any kind of list.

Yet another kind of list item symbol is `@ParagraphItem`, which introduces a list item whose labels are integrated into a paragraph:

```
@Heading { Extract from GNU General Public License }
@LeftList
@ParagraphItem {
You may copy and distribute verbatim copies of the Program's
source code as you receive it, in any medium, provided that you
conspicuously and appropriately publish on each copy an appropriate
copyright notice and disclaimer of warranty ...
}
@ParagraphItem {
You may modify your copy or copies of the Program or any portion
of it, thus forming a work based on the Program, and copy and
distribute such modifications or work under the terms of Section 1
above, provided that you ...
}
@endList
```

has result

Extract from GNU General Public License

1. You may copy and distribute verbatim copies of the Program's source code as you receive it, in any medium, provided that you conspicuously and appropriately publish on each copy an appropriate copyright notice and disclaimer of warranty ...

2. You may modify your copy or copies of the Program or any portion of it, thus forming a work based on the Program, and copy and distribute such modifications or work under the terms of Section 1 above, provided that you ...

Since the numbers are part of the item, the kind of list to use is just `@LeftList` rather than `@NumberedList`. It would be better if `@ListItem` could be used, but problems behind the scenes prevent this. `@ParagraphItem` has a `style` option that works much like the `style` option of `@List` described just below.

Another useful variation is the *multi-column list*, in which the items are spread over several columns within the current column. Any kind of list may be converted into a multi-column list. For example, here is how to get a multi-column bullet list:

```
@BulletList
  colnum { 3 }
  colgap { 1.0c }
  colheight { 5.0c }
```

followed by the list items and `@EndList` as usual. This list will appear spread over three columns, with the items placed down the first column, then down the second, and so on. The columns will have equal width, as wide as possible given that they are separated from each other by the gap given by `colgap`. Ideally, one would want the columns to have equal height, just enough to hold all the items; but since Lout is not clever enough to do this, you must specify a fixed height for each column, using the `colheight` option; and this height must be small enough to allow the entire list to fit onto one page, since it is effectively an unbreakable display.

The value of `colnum` must be either 1, 2, 3, 4, or 5. If it is 1 (the default value), `colgap` and `colheight` are not used and the result is an ordinary list. The value of `colgap` and `colheight` may be any width; the default values are those shown above. All the features available for ordinary lists and list items work in the usual way with multi-column lists: one may keep a list item in one column by enclosing it in `@OneRow`, cause a break to the next column using `@ListNewPage`, and so on. If there is not enough space in the columns to hold all the items (a real possibility since their height is fixed), any excess is dropped, sometimes with and sometimes without a confusing error message.

Every symbol introduced in this section has an abbreviated form consisting of `@` followed by its capital letters only. For example, `@RawNumberedList` abbreviates to `@RNL`, and `@ListItem` to `@LI`. The sole exception is `@RawList`, which has no abbreviation because `@RL` is the abbreviation for `@RomanList`.

Expert users will be interested to learn that all of the list symbols described in this section are derived from the two basic ones, `@List` and `@RawList`, merely by setting options. Here are all the options, together with their default values:

```
@List
  type { num }
  style { num }
  labelwidth { 2f }
  labelright { No }
  labelrightgap { 2s }
  indent { 0c }
  rightindent { 0c }
  gap { 1v }
  start { 1 }
  font { }
  break { }
  colnum { 1 }
  colgap { 1.0c }
  colheight { 5.0c }
```

These options may be used with all of the list and raw list symbols, except that some combinations don't make sense, for example `indent` with `@CentredList` or `style` with `@BulletList`, since

the list symbol has clearly already set the option.

The `type` option determines the type of numbering (Arabic, Roman, etc.) and is not intended for ordinary use, since there are distinct symbols for each type, as we have seen. The `style` option determines the format of the label, any `num` symbol within it being replaced by the number (in Arabic, Roman, etc. as determined by the `type` option) of the item. For example, `@ParenNumberedList` is just

```
@List
  style { (num) }
```

and `@BulletList` is just

```
@List
  style { @Bullet }
```

with `num` not mentioned since no number is wanted. The `@TaggedList` symbol and its variants also have the `style` option; in their case, the `num` symbol within it must be mentioned exactly once, and its value is set to produce the label supplied by the author.

The `labelwidth` option determines the width set aside for the labels; this is where `@WideTaggedList` and `@VeryWideTaggedList` differ from `@TaggedList`. If `labelright` is `Yes`, it means that the label is to appear right-justified in this width, apart from a width `labelrightgap` to the right of it to separate it from the content of the list item. The default value of `labelrightgap`, `2s`, is the width of two spaces. If `labelright` is `No`, `labelrightgap` is not used.

The `indent` and `rightindent` options determine the space left blank at the left and right margins. The value given to these options may be any length, for example `0.5i` (half an inch), or `0.5f` (half the current font size). Section 1.2 describes lengths in general. There are also three useful symbols denoting lengths: `@DisplayIndent` is the amount by which indented and quoted displays are indented; `@WideIndent` and `@VeryWideIndent` are the indents used by `@WideTaggedList` and `@VeryWideTaggedList`. Using these symbols helps to keep documents consistent.

The `gap` option determines the vertical space inserted between items. Once again this must be a length, although since it is vertical rather than horizontal, somewhat different kinds of lengths are appropriate: `1.5v` for 1.5 times the current vertical space between lines, or the default value, `@DisplayGap`, which produces the amount of vertical space used before and after displays. Owing to problems behind the scenes, there is no list option for the space before or after the list as a whole. To change this space in one list, use a raw list and insert your own paragraph symbols; to change it in every list there is a setup file option, described below.

The `start` option is the number assigned to the first item. It must be decimal:

```
@ParenRomanList
  start { 25 }
```

looks strange, but it is the correct way to number the first item (`xxv`).

The `font` option defines a font (or any value suited for the `@Font` symbol) which is to be applied to each item (but not the labels). For example, you might be bothered by the fact that a list item whose last line has no descenders in its letters is closer to the next list item, producing a slightly irregular appearance. One way to solve this problem is

```
@NumberedList
font { strut }
```

since the value `strut` given to the `@Font` symbol causes it to insert an invisible vertical strut into every word under the influence of that symbol. For more information, including another way to insert struts, consult Section 8.10.

The `break` option defines a break style (suitable for the `@Break` symbol) which is to be applied to each item. If you wanted each item in a ragged style, for example, you could just write

```
@NumberedList
break { ragged }
```

rather than laboriously enclosing each item in `ragged @Break`.

The last three options, `colnum`, `colgap`, and `colheight` work together to produce multi-column lists, as explained earlier. When the default value of `colnum` is used (i.e. 1), `colgap` and `colheight` are ignored and the result is an ordinary list.

Here is a larger example of these options in action. Setting both `indent` and `rightindent` to `@DisplayIndent` produces an effect similar to `@QuotedDisplay`:

```
preceding text
@List
style { @I {Item num}: }
indent { @DisplayIndent }
rightindent { @DisplayIndent }
labelwidth { @WideIndent }
start { 10 }
@ListItem { The vendor ... in the case of accident. }
@ListItem { The vendor ... adjacent to the facility. }
@endList
following text
```

The result is

```
preceding text

    Item 10: The vendor will not be liable for any injury caused by the escape of
    radiation or radioactive materials from the facility, nor for the costs of
    repair of any property damaged by nuclear blast or fallout in the case
    of accident.

    Item 11: The vendor will not be liable for any injury caused by radioactive
    materials being transported to or from the facility, nor for injury caused
    by radioactive materials stored adjacent to the facility.

following text
```

You can change the *default* values of the `labelwidth`, `labelright`, `labelrightgap`, `indent`, `rightindent`,

gap, and break options, by setting options called `@ListLabelWidth`, `@ListLabelRight`, `@ListLabelRightGap`, `@ListIndent`, `@ListRightIndent`, `@ListGap`, and `@ListBreak` options in the setup file (Section 4.1). These default values will then apply to every list in the document unless overridden by an option, just like the usual default values. The setup file also has a `@ListOuterGap` option which determines the gap before the first and after the last list item in non-raw lists.

2.3. Footnotes and endnotes

A footnote is created by typing

```
@FootNote { Like this. }
```

after the word that the footnote refers to. It will be numbered automatically and placed at the foot of the page or column;¹ or, if space there is insufficient, it may start on or run onto the following page or column. The footnote must be enclosed in braces.

The `@FootNote` symbol has a `@Location` option which determines where it goes:

```
@FootNote
  @Location { ColFoot }
{ ... }
```

places the footnote at the bottom of the column, and

```
@FootNote
  @Location { PageFoot }
{ ... }
```

places it at the bottom of the current page, occupying the full page width even in a multi-column document (this is occasionally useful for footnotes to headings). Of course, in a single-column document there is no difference anyway. The default value of the `@Location` option is `ColFoot`.

Endnotes work in exactly the same way as footnotes, except that the symbol to use is `@EndNote` and they appear either at the end of the document or at the end of some major part of it, depending on the type of document (Chapter 3). Endnotes are always column width and so have no `@Location` option.

Footnotes are usually labelled with consecutive Arabic numerals, but you can tell Lout to label a footnote (not an endnote) with something else, like this:

```
@FootNote
  @Label { @Dagger }
{ This footnote will be labelled with a dagger, not a number. }
```

whose result should appear at the bottom of this page.[†] Symbols commonly used for footnote labels include `@Dagger` (†), `@DaggerDbI` (‡), `@Star` (*), `@SectSym` (§), and `@ParSym` (¶), but you can use any object. If you want no label at all, use an empty object like this:

¹Like this.

[†]This footnote will be labelled with a dagger, not a number.

```
@FootNote
  @Label {}
```

Footnotes with a `@Label` option are excluded from the automatic numbering that applies to other footnotes.

The language of a footnote or endnote will be the language of the document as a whole. This is not necessarily the same as the current language at the point where the footnote or endnote occurs, or even the language of the enclosing large-scale structure symbol. It may be necessary to enclose the body of the footnote in a language symbol, like this:

```
@FootNote { French @Language { ... } }
```

Doing it the other way (French `@Language @FootNote ...`) is not effective.

A footnote attached to the very last line of a chapter or appendix of a book occasionally runs onto the first page of the following chapter or appendix, and this looks very poor. If this happens, the solution is to place an `@LP` after the last line (including the footnote).

In the rare case where more than one footnote is attached to one word, use `@AnotherFootNote` for the second and subsequent footnotes:

```
something or other.
@FootNote { The first footnote. }
@AnotherFootNote { The second footnote. }
```

This ensures that the superscripts will be separated by commas, as convention demands.

The setup file contains a number of options for controlling the appearance of footnotes. (See Section 4.1 for a general introduction to setup files and their options.) Here are all the options, with their default values:

```
@FootNoteThrough { No }
@FootNoteLocation { ColFoot }
@FootNoteNumbers { Arabic }
@FootNoteFont { 0.80f }
@FootNoteBreak { 1.20fx }
@FootNoteFormat { { number &0.05f } @Insert body }
@FootLen { 2.00c }
@FootAboveGap { 1.00v }
@FootGap { 0.20c }
```

There are also setup file options for controlling endnotes. Since they are quite similar to the ones for footnotes, we won't say any more about them here.

`@FootNoteThrough` may be `Yes` or `No`; `Yes` means that the footnotes are numbered continuously through the document (or through each chapter in the case of books); `No` means that the numbering begins afresh on each page. `@FootNoteLocation` determines the default value of the `@Location` option mentioned above; it may be either `ColFoot` or `PageFoot`.

`@FootNoteNumbers` determines how the footnotes are numbered; it may be `Arabic`, `Roman`, `UCRoman`, `Alpha`, or `UCAAlpha`, which give the obvious results. It may also be `Bullets`, which

uses sequences of bullets to mark the footnotes, following a style proposed by typographer Jan Tschichold, and it may be Symbols, which produces the traditional sequence of daggers and similar symbols.

@FootNoteFont and @FootNoteBreak determine the font and paragraph breaking style of footnotes. The default value of @FootNoteFont produces the same font family and face as the bulk of the document, but reduced to 0.8 times the original size.

@FootNoteFormat determines the format of the footnote. The number symbol within it must appear exactly once, and is replaced by the number of the footnote (if numbered). The body symbol is replaced by the body (that is, the content) of the footnote. The default value shown uses symbols from raw Lout to add a small space at the right of the number, then insert it at the beginning of the first paragraph of the body. Another suitable value might be

```
@FootNoteFormat { number |1fx body }
```

which places the body in a separate column to the number, one font width to the right of the left edge of the number.

@FootLen determines the length of the small horizontal line drawn above the footnotes; @FootAboveGap determines the minimum space to be left clear above this line; and @FootGap determines the vertical separation between footnotes. All three may be any length.

2.4. Margin notes and arbitrary placement

A note can be placed in the left margin by typing

A left note. @LeftNote { A left note. }

after the word that the note refers to. The note will appear in the margin at the same height on the page as that word, unless that would cause it to overlap a previous margin note, in which case it will be shifted downwards (but never onto the next page). The note may be an arbitrary Lout object; for example, you might type

A left note. @LeftNote @I { A left note. }

to make your note come out in italics.

You can get a note in the right margin by using @RightNote instead of @LeftNote. To get a note in the outer margin (left on even pages, right on odd pages), use @OuterNote; and for the opposite, use @InnerNote.

An inner note.

A right note.

An outer note.

By default, Lout produces margins that are 2.5 centimetres wide, which is not really enough to accommodate reasonable margin notes. To change these margins, you need to change options in the setup file, as explained in Section 4.3.

The appearance of the margin notes themselves is also determined by options in the setup file (for a general introduction to setup files and their options, consult Section 4.1). Here are the options and their default values:

```

@MarginNoteFont { 0.80f }
@MarginNoteBreak { ragged 1.10fx }
@MarginNoteHGap { 0.5c }
@MarginNoteVGap { 1.00v }
@MarginNoteWidth { 1.50c }

```

`@MarginNoteFont` determines the font; the default value produces the current font scaled to 0.8 times the current size. Slope 0.80f would yield italic notes, and so on. `@MarginNoteBreak` is the paragraph breaking style, similar to the `@InitialBreak` setup file option.

`@MarginNoteHGap` determines how far away from the adjacent text column the margin note will appear; the default value is 0.5 centimetres. Notice that, by this definition, margin notes will appear in the page body margin (Section 4.3) if there is one. `@MarginNoteVGap` is the minimum vertical separation between margin notes (i.e. it determines how far downwards a note will be shifted to avoid the previous one). `@MarginNoteWidth` determines the width of the column in which margin notes (both left and right) are set; the default value of 1.5 centimetres is suited to the 2.5 centimetre page margins that are the default, but if you widen the page or page body margins you will be able to increase `@MarginNoteWidth` too.

Left notes extend into the left margin (including the left page body margin) a total distance of `@MarginNoteHGap` plus `@MarginNoteWidth`, and it is up to you to make sure that this does not put them off the page. Similar remarks apply to right notes. And since notes are never shifted to the next page, only downwards, there is also a risk that a note will be shifted off the bottom of the page, if it is very long or if preceding notes obstruct it. Again, it is up to you to avoid this problem by keeping your notes small and not too close together.

Hello

Margin notes inside footnotes, figures and tables work well. Margin notes in multi-column documents are disastrous unless used very sparingly. Margin notes do not appear in plain text output (Section 3.6).

A more radical way to place objects at arbitrary points on the current page is provided by the `@Place` symbol:

```

@Place
  x { right - 1c - xsize }
  y { { foot + top } / 2 }
{
  @Box { Hello }
}

```

The placed object may be any object. This particular example produces a box whose x (horizontal) position is such that its right edge is one centimetre from the right edge of the page, and whose y (vertical) position is halfway up the page.

In addition to numbers, with or without units of measurement (Section 1.2), the following symbols may be used inside the x and y options:

left	The left edge of the page
right	The right edge of the page
foot	The foot edge of the page
top	The top edge of the page
+	Addition (positive is to the right and up)
-	Subtraction (negative is to the left and down)
*	Multiplication
/	Division
xsize	The width of the object being placed
xmark	The column mark of the object being placed (for expert users)
ysize	The height of the object being placed
ymark	The row mark of the object being placed (for expert users)

Negative numbers have to be enclosed in double quotes to avoid the initial - being mistaken for subtraction. The usual precedences and associativities apply to the mathematical operators; braces (not parentheses) may be used for grouping. It is best to give values to x and y that do not depend on any assumptions about where the coordinate system's origin is; this is true of the examples above. At the point where `@Place` occurs, the result is an empty object. As with margin notes, `Lout` does not know what is happening and will not lay out the rest of the page around the placed object.

2.5. Theorems, lemmas, corollaries, definitions, propositions, examples, and claims

A theorem is created like this:

```
@LD @Theorem
  @Title { Fermat's Last Theorem }
{
  @M {  $a^n + b^n \neq c^n$  } for all positive integers @M {  $a$  },
  @M {  $b$  }, @M {  $c$  } and @M {  $n$  } when @M {  $n > 2$  }.
  @LP
  @Proof I have a proof of this theorem, but the margin
  is too small to contain it. @EndProof
}
```

where we have used the `@LD` 'left display' symbol from Section 2.1 to get a left-justified display, and the `@M` symbol from Chapter 7 for the equations. The result is

Theorem 2.1 (Fermat's Last Theorem): $a^n + b^n \neq c^n$ for all positive integers a , b , c and n when $n > 2$.

Proof: I have a proof of this theorem, but the margin is too small to contain it. □

The `@Theorem` symbol produces an object with no adjacent vertical space, hence it needs to be used in conjunction with display or paragraph symbols. The theorem is numbered automatically, with the title and number inserted at the start of the first paragraph. `@Title` may be omitted.

`@Proof` produces **Proof:** with the appropriate following space, and `@EndProof` produces a box at the end of the line. They may be used anywhere, not just within theorems.¹

There are seven symbols that produce independently numbered sequences in this way. They are `@Theorem`, `@Definition`, `@Claim`, `@Proposition`, `@Lemma`, `@Corollary`, and `@Example`.

The setup file contains options which determine whether the theorem numbers include a chapter number (`@ChapterNumInTheorems`), or a section number (`@SectionNumInTheorems`), and so on. A section number automatically includes a chapter number, etc. There are also options to change the word printed. For example, if you need a sequence of conjectures, change the `@ClaimWord` setup file option to

```
@ClaimWord { Conjecture }
```

and use the `@Claim` symbol for your conjectures. You can even put

```
import @DocumentSetup
macro @Conjecture { @Claim }
```

into your `mydefs` file (Section 2.13) if you wish, so that you can write `@Conjecture` in your documents instead of `@Claim`.

The setup file also contains two options which control the format of the theorem (claims and so on have corresponding options). Here they are with their default values:

```
@TheoremTitleFormat { (title) }
@TheoremFormat { { @B { word @NumSep number title: } &2s } @Insert body }
```

The first option is used only when a `@Title` is given to the theorem, and it determines how the title is formatted: the title symbol within the option stands for the `@Title` option. The default value shown places parentheses around the title. The second option determines the format of the entire theorem. Within it, `word` stands for the value of `@TheoremWord`; `number` is the number of the theorem; `title` is the title of the theorem after formatting by `@TheoremFormat` (if there is a title; otherwise `title` is `@Null`, which prints as nothing and even deletes the preceding space as required); and `body` is the body of the theorem. The default value prints the word, number and title with a colon in bold, and inserts them and two spaces into the first paragraph of the body; another value might be

```
@TheoremFormat { @B { word @NumSep number title } @LP body }
```

which places the header in bold on a line by itself, separated from the body by a paragraph break. For `@NumSep` see page 114.

Owing to problems behind the scenes, the `@Theorem` symbol and its companions have a potential efficiency problem: although all numbers are finalized on the second run, it takes Lout time proportional to the square of the highest theorem number to do this. So large numbers of theorems numbered together might be slow.

¹ Occasionally `@EndProof` does not appear as far to the right as it should. This problem can be fixed by using `@LD @HEXpand @Theorem`, which instructs Lout to make sure that as much horizontal space as possible is allocated to the theorem.

2.6. Figures and tables

Figures are created in a similar way to footnotes:

```
@Figure
  @Caption { Basser Lout }
  @Diag vstrut { yes } treehsep { 1c } {
    @HTree { @Box Lout @FirstSub arrow { yes } @Box PostScript }
  }
```

The `@Figure` symbol places the following object (which in this example is created using the advanced graphics features of Chapter 9) at the top of the following column or page, labelled by the `@Caption` option and automatically numbered. You can see this example at the top of page 48. Tables are obtained in the same way using `@Table` instead of `@Figure`. There is a third symbol called `@Floater`. It won't be mentioned again, but it works exactly like `@Figure` and `@Table`.

`@Figure` and `@Table` each have an `@InitialLanguage` option which determines the language of the figure or table. If this is omitted, the language of the document as a whole will be used, not the language where the figure or table occurs.

The two symbols also have a `@CaptionPos` option, which determines whether the caption appears above or below the figure or table. The default is `Below`, the alternative is `Above`.

The question of what is a suitable running header to print on pages containing figures and tables (possibly from different sections) is a rather awkward one. On any page with a figure or table at the top, Lout uses whatever running header was appropriate for the text on the previous page. In practice it seems to work quite well.

If your document contains many figures, large figures, or multi-page figures, you are likely to encounter cases where Lout's assignment of figures to pages is not pleasing. In that case, you can improve things by moving the figures around within the body text, and by using the `@Location` option of the `@Figure` symbol, which determines where the figure will appear. Its possible values are

<code>PageTop</code>	The figure will appear at the top of the following page, occupying the full page width; or, if there is insufficient space there (owing to other figures already present), at the top of the first subsequent page with sufficient space.
<code>EvenPageTop</code>	Like <code>PageTop</code> except that the first page of the figure or table will be an even-numbered (left-hand or verso) page – useful for double-page spreads.
<code>FullPage</code>	Like <code>PageTop</code> except that nothing else will appear on the same page as the figure except the usual running headers and footers, and possibly other <code>FullPage</code> figures and tables. ¹
<code>EvenFullPage</code>	Like <code>FullPage</code> except that the first page of the figure or table will be an even-numbered (left-hand or verso) page, like <code>EvenPageTop</code> .

¹This location replaces the `@FullPage` option of earlier versions of Lout, which has been withdrawn.

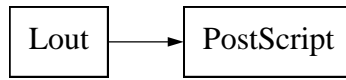

Figure 2.1. Basser Lout

PageFoot	The figure will appear at the foot of the current page, occupying the full page width; or, if there is insufficient space there, at the top of the following page and so on as for PageTop.
ColTop	The figure will appear at the top of the following column, occupying the column width; or, if there is insufficient space there, at the top of the first subsequent column with sufficient space. This is different from PageTop only in multi-column documents.
ColFoot	The figure will appear at the foot of the current column, occupying the column width; or, if there is insufficient space there, at the top of the following column as for ColTop. This differs from PageFoot only in multi-column documents.
ColEnd	The figure will appear in a column at the end of the document (or chapter, appendix etc. in the case of books). There is no PageEnd value corresponding to ColEnd.
AfterLine	The figure will appear as a column-width display immediately after the line in the final printed document in which it occurs.
TryAfterLine	The same as AfterLine unless there is insufficient space in the current column to hold the displayed figure, in which case it switches to ColTop instead.
Display	The figure will appear as a display at the point it occurs. There is no TryDisplay value corresponding to Display.
Raw	The figure will appear as an object, with no extra spacing, at the point it occurs. This is useful, for example, for getting two figures side by side in one display: use a displayed table containing two raw figures.

The @Table symbol also has this option. The default location is PageTop, but this can be changed by changing the @FigureLocation and @TableLocation setup file options.

The numbers assigned to figures and tables, and their ordering in any list of figures or tables, is based on where they appear in the final printed document, not on where they appear in the source files. This is better for the reader in the unusual case of a fixed figure being overtaken by a floating one. If a section number is printed as part of a figure number, and the figure floats forward from one section into another, the figure number will reflect the later section, not the earlier one as it should. You can fix this problem by moving the figure to an earlier point in the section, or by not having section numbers in figures (see below).

@Figure and @Table each have a @OnePage option, whose value may be Yes or No. Setting @OnePage to Yes causes the figure or table and its caption to be kept together on one page or column (enclosing the body of the figure or table in @OneRow would have the same effect except that it would not incorporate the caption, hence the need for this option). You need to be certain that the whole assembly will fit on one page when setting @OnePage to Yes. If it doesn't, Lout should warn you with a message such as

25.3c object too high for 23.4c space; will try elsewhere

giving the size of the oversize object and the size of the space it failed to fit into; but (unfortunately) it does not give a clear indication of whether trying elsewhere succeeded or not. When you see this message you need to check for yourself whether the figure was actually printed or not; it may mean merely that the figure was put back to a later page than the first possible one.

The *default* value of the @OnePage option for each figure or table depends on the value of its @Location option as follows:

No	PageTop	ColTop	ColEnd	Raw
Yes	PageFoot	ColFoot	Display	AfterLine TryAfterLine

These choices represent a guess that figures that the user is happy to see at the page foot or in a display are probably going to be small enough to keep on one page, but that other figures may not be. In any case, these are only default values and you may set @OnePage as you wish.

By default, the body of the figure will be centred, and this usually looks best, at least for small figures. @Figure and @Table each have a @Format option which controls this format:

```
@Figure
  @Format { @CurveBox @HExpand @CC @Body }
```

Within the @Format option, the @Body symbol stands for the body of the figure or table; it must appear exactly once. Display symbols such as @CentredDisplay may not be applied to the @Body symbol; instead, there are @ll, @QQ, @CC, and @RR, which indent, quote, centre, or right-justify the following object. The example just given centres the figure inside a @CurveBox which is horizontally expanded (by the @HExpand symbol, which is not specific to figures) to occupy the full width of the page or column, rather than fitting snugly around the figure.

Although @CC will always centre the figure or table, occasionally it underestimates the amount of space available to centre in, and hence the figure or table appears only partly centred, or even left justified. This occurs when nothing on the page extends the full width of the page. If this problem occurs, use

```
@Format { @HExpand @CC @Body }
```

The @HExpand symbol expands the space available to the following object to the maximum possible amount, so that the centring is with respect to the full available width as desired.

The @Format option applies to just the body of the figure, not to its caption. It applies to each page or column of a multi-page or multi-column figure; for example, the above format will draw a box around each page of a multi-page figure, and each page will be separately centred. ColEnd and Raw figures are exceptions to this rule: they always apply the format to the figure as a whole. This means that you cannot box multi-page figures of these two types, since the result would be an unbreakable object too large to fit on one page.

There are setup file options for controlling the appearance of figures and tables. Only those for figures will be given here, since the ones for tables are identical except that Table replaces Figure in their names. Here they all are:¹

¹These are as of Version 3.15 and above. Prior to that there were @CaptionFont, @CaptionBreak, and @CaptionFormat options, and @CaptionFormat took values that did not include the caption symbol.

```

@FigureLocation { PageTop }
@FigureFormat { @CC @Body }
@FigureWord { figure }
@FigureNumbers { Arabic }
@FigureCaptionPos { Below }
@FigureCaptionFont { }
@FigureCaptionBreak { }
@FigureCaptionFormat { @B { word @NumSep number. &2s } @Insert caption }
@MakeFigureContents { No }
@FigureListWord { figurelist }

```

`@FigureLocation` is the default value of the `@Location` option of figures. Changing it, for example to `FullPage`, changes the location of all figures at once. You may still override this location for any individual figure, however, by giving that figure a `@Location` option. In a similar way, `@FigureFormat` is the default value of the `@Format` option (this shows why figures are centred by default) and `@FigureCaptionPos` is the default value of `@CaptionPos`.

`@FigureWord` determines the word that is part of the figure number. The default value, `figure`, produces ‘Figure’ or its equivalent in the current language; any other value produces itself.

`@FigureNumbers` determines whether figures are numbered automatically or not; the choices are `None`, `Arabic`, `Roman`, `UCRoman`, `Alpha`, and `UCAAlpha`. Depending on the document type and where the figure or table occurs, the number might include a chapter number as well. This is determined by options in the setup file for your document type; for example,

```
@SectionNumInFigures { No }
```

appears in the report setup file, and means that a section number will not appear in the figure number (unless you change the option to `Yes`).

`@FigureCaptionFont` and `@FigureCaptionBreak` determine the font and paragraph breaking style used in the captions of figures. Their default values are empty, meaning to use the initial font and break styles; but, for example, you could have

```
@FigureCaptionFont { -2p }
```

in your setup file to get a smaller font size in your captions.

The `@FigureCaptionFormat` option determines the format of the caption. Within it, the symbol `word` stands for the ‘Figure’ word as defined by `@FigureWord`; the number symbol stands for the number of the figure; and `caption` stands for the body of the caption. The default value shown above prints the word and number and a period in bold, inserted together with a gap of two spaces into the first paragraph of the caption. If you don’t use the `@Insert` symbol you’ll run into problems with multi-paragraph captions.

You can get a list of figures at the start of your document by setting the `@MakeFigureContents` setup file option to `Yes`. The format of these lists will follow the format of tables of contents. These lists are only available in books (Section 3.3). The title printed above the list of figures is determined by the `@FigureListWord` option; the default value, `figurelist`, produces ‘List of Figures’ or its equivalent in the current language; any other value produces itself.

2.7. Large-scale structure: chapters, sections, etc.

Lout's large-scale structure symbols vary with the type of document (@Chapter for books, @Overhead for overhead transparencies, etc.), but they all work in the same way. Here is a typical example, @Section, as it would actually be used:

```
@Section
  @Title { Allocation of teachers }
@Begin
@PP
Apart from the usual need to avoid clashes, the allocation of teachers must
ensure that no teacher teaches more than seven periods per day, or ...
@End @Section
```

First comes the symbol itself, then any options in the usual way, and then the following object, enclosed in @Begin and @End @Section. The following object, also called the body of the section, may contain paragraphs, displays, and all the other features as usual. The body should begin with a paragraph symbol, which may be @PP or @LP as you prefer. The result is a section like the present one, automatically numbered, with the @Title option for its heading, preceded by a conditional new page symbol (Section 1.8).

When @Section symbols are used within an ordinary document, they must be bracketed by @BeginSections and @EndSections symbols, like this:

```
@SysInclude { doc }
@Doc @Text @Begin
preceding text
@BeginSections
@Section ... @End @Section
@Section ... @End @Section
...
@Section ... @End @Section
@EndSections
@End @Text
```

This arrangement is reminiscent of the one for lists, and, as for lists, there may be no paragraph or new page symbols before, between, or after the sections.

The @Begin ... @End @Section that brackets the body of each section may be abbreviated to { ... }. However, the long form is recommended because it helps Lout to detect missing or extra braces within the body of the section.

To change the gap between sections, you need to change the @SectionGap option in the setup file, as explained in Chapter 3. If you just want a new page or column before one section, then use the @NewPage option of that section, like this:

```

@Section
  @Title { Bandicoots and quolls }
  @NewPage { Yes }
@Begin
...
@end @Section

```

The `@NewPage` option is only available with large-scale structure symbols that usually do not appear on a new page (like `@Section`), and it forces them to appear on a new page. You can't use it with large-scale structure symbols that usually appear on a new page (like `@Chapter`) to force them not to – there is no way to do that.

All large-scale structure symbols have a `@Tag` option, whose use is explained in Section 2.8, and a `@RunningTitle` option. If running page headers have been requested, `@RunningTitle` will be used if it is given, otherwise `@Title` will be used for the running header. For example, the present section begins like this:

```

@Section
  @Title { Large-scale structure: chapters, sections, etc. }
  @RunningTitle { Large-scale structure }
  @Tag { largescale }
@Begin
...

```

The point is that the section title is rather long for a running title, and so we use `@RunningTitle` to get an abbreviated version of it.

Section titles typically appear in Bold face in the section heading, but in Roman face in tables of contents and running page headers. So if part of your title is in italics, enclose it in `@I` rather than just `@I` to ensure that you get the right kind of italics in both contexts.

All large-scale structure symbols also have an `@InitialLanguage` option which sets the current language for the duration of that symbol. However, footnotes, endnotes, figures, tables, references, and index entries are set in the initial language of the document as a whole, unless you change their language explicitly using the `@Language` symbol.

The remainder of this section describes the setup file options for controlling the appearance of large-scale structure symbols. (For an introduction to setup files, consult Section 4.1.) These options mainly appear in the third `@Use` clause, since exactly which large-scale structure symbols exist depends on the type of document. For example, here are the setup file options from the doc setup file relating to appendices:

```

@AppendixWord { appendix }
@AppendixNumbers { UCAAlpha }
@FirstAppendixNumber { 1 }
@AppendixHeadingFont { Bold }
@AppendixHeadingBreak { ragged 1.2fx nohyphen }
@AppendixHeadingFormat { number @DotSep title }
@AppendixGap { 2.0v @OrlfPlain 2f }
@AppendixInContents { Yes }
@AppendixNumInTheorems { No }
@AppendixNumInDisplays { Yes }
@AppendixNumInFigures { No }
@AppendixNumInTables { No }
@AppendixPrefix { }

```

There are similar options for each large-scale structure symbol. Here is a brief explanation.

`@AppendixWord` contains the word that is to be prefixed to the appendix number in full headings. The special value `appendix` produces `Appendix` or its equivalent translated into the current language. Any other value produces itself.

`@AppendixNumbers` determines the style of numbering of appendices, and may be `Arabic`, `Roman`, `UCRoman`, `Alpha`, `UCAAlpha`, or `None` meaning unnumbered. Most common is `Arabic`, but appendices traditionally use upper-case letters, hence the value `UCAAlpha` given above.

`@FirstAppendixNumber { 1 }` is the number (always in `Arabic`) to assign to the first appendix. It is almost always 1, but a few people like to start their numbering from 0; this is only possible if the style of numbering specified by `@AppendixNumbers` is `Arabic`.

`@AppendixHeadingFont` and `@AppendixHeadingBreak` specify the font and paragraph breaking style to be applied to the appendix heading (relative to `@InitialFont` and `@InitialBreak`); the default values shown above produce `Bold` in the current font family and size, and ragged breaking without hyphenation.

`@AppendixHeadingFormat` defines the format of the appendix heading. Within it, the symbols `number` and `title` stand for the appendix number (including the appendix word) and title respectively. The `@DotSep` symbol produces a dot and two spaces, except when there is no number, when it produces nothing. For example, to draw a full-width rule under the heading, change this option to

```
@AppendixHeadingFormat { number @DotSep title @LP @FullWidthRule }
```

Arbitrary formats are acceptable.

`@AppendixGap` determines the vertical space to leave between appendices; the default above leaves `2v`, except that when plain text output is in effect it leaves `2f` instead. To get a new page between appendices, use the magic value `2b`, which is raw `Lout` for new page. In books, the major components (preface, introduction, tables of contents, parts, chapters, appendices, and indexes) always start on a new page and there is nothing you can do to change that.

`@AppendixInContents` determines whether the appendix will be listed in the table of contents, and may be `Yes` or `No`. The next few options determine whether an appendix number will be included in the numbers assigned to theorems etc., numbered displays, figures, and tables.

There is a `@StructPageNums` setup file option which determines whether page numbers will include the numbers of large-scale structure symbols. If it is Yes, `@AppendixPrefix` is prefixed to all page numbers of pages containing appendices. For example, setting `@AppendixPrefix` to APP- produces page numbers APP-A-1, APP-A-2, and so on. The object separating each element of such compound numbers is determined by the `@NumberSeparator` setup file option, which has default value . but which can easily be set to - or -- if desired.

Running page headers above appendices always include the title of the appendix, so there is no option for specifying whether to do so or not. But for subappendices and other such smaller units, the choice of whether to mention them in running headers is left to the user:

```
@SubAppendixNumInRunners { Yes }
```

Despite the misleading name, this option determines whether the entire subappendix *title* as well as number will be used as a running header.

2.8. Cross references and links

Cross references are a useful feature of documents, but they are a problem for authors. Suppose that at one point of your document you have

We hold these truths to be self-evident, that all men are created equal,
that they are endowed by their Creator with certain inalienable Rights,
that among these are Life, Liberty, and the pursuit of Happiness...

and that at some other point, earlier or later, you have

The anti-slavery cause, founded as it was on the Declaration
of Independence (page 181), could appeal to patriotic as
well as moral sentiments...

This is a *cross reference*, and the problem is that as the document is revised, the Declaration of Independence might move to page 185, and the cross reference must be found and changed.

Lout has a simple solution to this problem. Instead of writing the page number, write

The anti-slavery cause, founded as it was on the Declaration
of Independence (page `@PageOf { decl.of.ind }`), could appeal to
patriotic as well as moral sentiments...

instead, and at the point referred to, write

We `@PageMark decl.of.ind` hold these truths to be self-evident, that...

Inserting `@PageMark decl.of.ind` will not affect the result, but Lout makes a note of the number of the page on which the word preceding it appears, and inserts that number in place of `@PageOf decl.of.ind`. The tag, `decl.of.ind`, may be any simple word (actually Lout will accept a multi-word tag, but they are very inconvenient and better avoided). The braces are there, as usual, to control grouping: we don't want the following punctuation characters in the tag.

One tag called `last.page` is created automatically for you. `@PageOf last.page` gives the

number of the last page of the document. For example, the result for this document is 327.

Cross referencing also applies to large-scale structure symbols such as @Chapter and @Section (any symbol with a @Title option), as well as @FootNote, @EndNote, @Figure, @Table, @Floater, the numbered display symbols, and @ListItem and @DropListItem (but not @TagItem and @DropTagItem). Each of these symbols has a @Tag option:

```
@Section
  @Title { Cross references }
  @Tag { cross }
@Begin
@PP
Cross references are a useful ...
```

Now you can use the @PageOf symbol to find the number of the page on which the symbol's result begins, and the @NumberOf symbol to find its number:

```
For further information on this point, please consult
Section @NumberOf cross (page @PageOf { cross }).
```

produces

For further information on this point, please consult Section 2.8 (page 54).

For symbols with a @Title option (chapters, sections, etc.) or a @Caption option (@Figure, @Table, and @Floater) there is also the @TitleOf symbol, which returns the value of the @Title or @Caption option:

```
For further information on this point, please consult
the @TitleOf { cross } section.
```

produces

For further information on this point, please consult the Cross references and links section.

But this symbol won't work for footnotes, list items, and other things without a title or caption.

For those with more expertise in using Lout, there is a @PageParityOf symbol which is very similar to @PageOf except that it returns one of the two words Odd and Even instead of a page number, indicating whether the object it references is printed on an odd or even page. For example, @PageParityOf cross produces Even.

Like all tags, the value of the @Tag option should be a simple word (although Lout does accept multi-word tags). Cross referencing of list items yields just the number of the item, in Arabic, Roman, or whatever; it does not include the surrounding parentheses or other decorations introduced by the list's style option.

To work cross references out, Lout has to process your document more than once, storing information between runs in special files it creates whose names end in .li and .ld. A complex document like this Guide requires five runs, but since every run produces a perfectly good PostScript file suitable for proof reading, in fact you need two runs to start with and one run per

cycle of revision thereafter, only one more than would have been necessary in any case.

The cross referencing system assumes that each Unix directory contains only one Lout document (possibly spread over many files). If you keep several documents in one directory you can turn off the cross referencing with the `-s` flag:

```
lout -s simple > simple.ps
```

Since this will cause question marks to replace footnote and section numbers, and other products of cross referencing, it is only feasible for simple documents. Alternatively, you can reset cross referencing when switching from one document to another, by removing file `lout.li`. You should also remove this file if your document changes radically – from a report to a book, say.¹

PDF viewers and recent versions of PostScript viewers offer a high-tech version of cross references called *links*, which allow the user to click on, say, the entry for a section in a table of contents and be immediately transported to the page on which that section begins. In principle, anything could happen when a link is clicked on, but Lout only offers two kinds of links: *internal links* that transport the user to some page in the current document, and *external links* that transports the user to a URL location on the World Wide Web.

Lout automatically makes an internal link out of every page number it prints in the table of contents and in the index, and every reference citation. You can also insert your own links, using the `@CrossLink` symbol like this:

```
See cross @CrossLink { Section @NumberOf cross }
```

The `@CrossLink` symbol consumes two objects, one to its left and the other to its right, and we'll explain each of these now.

The object on the right (`Section @NumberOf cross` in our example) can be an arbitrary Lout object: you don't have to have `@NumberOf` or `@PageOf` inside it, although in practice you often will, since it makes sense to put a low-tech link wherever you have a high-tech one, for the benefit of readers of paper versions. This object on the right is what is printed, so the overall result in this example is

```
See Section 2.8
```

But, beyond this, clicking anywhere on this object on the screen will invoke the link, transporting the user to some other page.

The object on the left (`cross` in our example) must be a tag that is acceptable to the `@PageOf` symbol described earlier in this section. The link will transport the user who clicks on it to the

¹An unfortunate and long-standing bug causes Lout to crash occasionally when reading from a cross-reference database file that it wrote on the preceding run. The problem has to do with mistakenly taking a literal word, or part of such a word, as an invocation of a symbol. The crash will occur on the *second* run (because the database file is written, not read, on the first run), and might be accompanied by an error message mentioning routine `AttachEnv` or `SetTarget`. You can make it happen, for example, by including

```
pnformat @Index { watch me crash! }
```

in your document – the `pnformat` tag, a literal word, will be mistaken for the `pnformat` option of `@Index` by the database reader. If this problem appears, try enclosing tags that you entered recently in double quotes. Enclosing `pnformat` above in double quotes fixes the example problem.

page that `@PageOf` would point to if given that tag. You can ensure that your tag is acceptable in the usual ways: by using `@PageMark`, or by giving the tag as the `@Tag` option of a chapter, section, etc. as described earlier in this section.

A moment ago we said that the object to the right of `@CrossLink` is what is printed by the `@CrossLink` symbol. This is true by default, but there is a `@CrossLinkFormat` option in the setup files which allows you to change the appearance of this printed object. (See Section 4.1 for a general description of setup files and their options.) The default value of `@CrossLinkFormat` is

```
@CrossLinkFormat { @Body }
```

Within the `@CrossLinkFormat` option, the `@Body` symbol stands for the object to the right of `@CrossLink`. It is actually the value of `@CrossLinkFormat` that is printed, so, for example, changing it to

```
@CrossLinkFormat { blue @Colour @Underline @Body }
```

causes all link objects to be printed in blue and underlined. If you want a special format just for one link, there is a `@Format` option to `@CrossLink` that overrides `@CrossLinkFormat`:

```
cross @CrossLink @Format { @CurveBox @Body } { Section @NumberOf cross }
```

You can also give the formatting you want directly, since the object to the right of `@CrossLink` can be an arbitrary Lout object:

```
cross @CrossLink @CurveBox { Section @NumberOf cross }
```

However, in this form the `@CrossLinkFormat` setup file option is still applied.

External links are obtained in much the same way as internal ones, except that the symbol to use is `@ExternalLink` and instead of supplying a tag, you need to supply a URL:

```
"http://lout.wiki.sourceforge.net/" @ExternalLink { Lout Home Page }
```

Once again the result is the object to the right, modified by any `@Format` option; and there is an `@ExternalLinkFormat` setup file option that works in the same way as `@CrossLinkFormat`. This time, though, the effect is to jump right out of your document to the given place on the World Wide Web, assuming that the software you are using to display your document is capable of such a thing.

At present, the `@CrossLink` and `@ExternalLink` symbols behave as though a `@OneCol` symbol encloses the object to their right. This means that that object is kept together on one line of any enclosing paragraph, and inter-word spaces within it are not adjusted along with the inter-word spaces of any enclosing paragraph. This deficiency might be corrected in the future, but meanwhile it means that it is best to keep your objects on the right short.

2.9. Tables of contents

Lout takes note of the titles of all your large-scale structure symbols (Section 2.7) and what pages they begin on, and it uses this information to produce a table of contents like the one at the start of the present document. It is totally automatic; you do nothing.

Some details of the appearance of the table of contents, including whether to make one or not, are controlled by options in the setup file. The default setting is to make one in books but not to in other types of documents, but by changing the setup file you can have a table of contents in any type of document.

Section 4.1 describes setup files in general and how to change the options within them. The options relevant to tables of contents and their default values are:

```
@MakeContents { No }
@ContentsGap { 0.2v }
@ContentsGapAbove { 0.8v }
@ContentsGapBelow { 0.0v }
@ContentsFont { Bold }
@ContentsPartGapAbove { 1.0v }
@ContentsPartGapBelow { 0.0v }
@ContentsFormat { number @DotSep title }
@ContentsLeader { .. }
@ContentsLeaderGap { 4s }
@ContentsRightWidth { 3f }
```

The `@MakeContents` option may be `Yes` or `No`, and determines whether a table of contents is made or not. Its default value is `No` but it is set to `Yes` in the book setup file.

`@ContentsGap` determines how much vertical space to leave above each line of the table of contents, in addition to the usual single line spacing; its value may be any length (Section 1.2). The default value, `0.2v`, is twenty percent of the current inter-line spacing.

Some entries, such as those for chapters and appendices in books, are more important than others. `@ContentsGap` does not apply to these entries; instead, `@ContentsGapAbove` and `@ContentsGapBelow` are used above and below each of them, again in addition to the usual single line spacing. `@ContentsFont` also applies only to these ‘major entries’, and determines their font. The default value causes them to appear in **Bold**.

`@ContentsPartGapAbove` and `@ContentsPartGapBelow` are like `@ContentsGapAbove` and `@ContentsGapBelow`, except that they are used before and after contents entries that denote book parts.

`@ContentsFormat` determines the format of each entry of the table of contents. Within it, `number` stands for the number of the chapter, section, or whatever, and `title` for its title. The default value, `number @DotSep title`, produces the number followed by a dot, two spaces, and the title, or just the title if there is no number.

`@ContentsLeader` is the object which is repeated across the page to connect each entry with its page number; popular values are `..` and `.` and the empty object. `@ContentsLeaderGap` determines how far apart these objects are; the default value, `4s`, is four times the width of a space character. `@ContentsLeaderGap` may be `0s`, but only if `@ContentsLeader` is non-empty.

`@ContentsRightWidth` reserves some space at the far right for page numbers. Any entry wide enough to intrude into this space is broken into two or more lines to keep it clear.

In addition to these options, each document type has options that determine which large-scale structure symbols will be listed in the table of contents. For example, among the options

to the @BookSetup symbol in the book setup file are these:

```
@ChapterInContents { Yes }
@sectionInContents { Yes }
@SubSectionInContents { Yes }
@SubSubSectionInContents { No }
@AppendixInContents { Yes }
@SubAppendixInContents { Yes }
@SubSubAppendixInContents { No }
```

Each may be either Yes or No; these default values produce entries for everything except sub-subsections and sub-subappendices.

2.10. Glossaries

A glossary¹ is a section at the end of a document containing terms and their definitions, with a reference back to the page of the document where each term is first used. It's similar to an index, except that there are fewer entries and they are longer and more spaced out – for reading rather than just reference.

In order to get a glossary, you have to be using either the book or report setup file, and you have to make your own copy of the setup file (as described in Section 4.1) and change the @MakeGlossary option within it to Yes. Lout does not insert a glossary automatically. The glossary will appear at the end of the document, immediately before any index.

To make an entry in the glossary, place something like this in your main text at the point you are defining the term:

```
Object @Glossary {
  Part of a document occupying a rectangular area;
  may be a simple word, or a collection of smaller
  objects composed in arbitrary ways.
}
```

The object to the left of @Glossary is the term being defined, and the object to the right is its definition. Nothing will appear in the main text where you put this, but the term will appear in the glossary, accompanied by its definition and the page number of this spot.

The term should be just a word or a short sequence of words. The definition may be as long and complex as you wish, containing paragraphs, displays, and so on.

The glossary items will appear sorted alphabetically. You can use the sortkey option of @Glossary to provide a separate sorting key:

```
{@Char flori} @Glossary sortkey { flori } {
  The flori character.
}
```

¹The features described in this section are closely based on a design by Thorsten Seitz.

This entry will appear in the list where things beginning with `f` do, not where the florin character code would place it. If you do this, since the term being defined is no longer used as a sort key it is free to be an arbitrary object, not restricted to be a word or a short sequence of words.

Creating a glossary entry does not automatically create an index entry (Section 2.11). If you want an index entry for your glossary term as well (as you probably will) you need to make that separately, and you will need to use a different tag from the tag used by the glossary entry (which is either the term being defined, or `sortkey` if given). To make an index entry that points into the actual glossary, which you also probably need, just place your index entry somewhere inside the definition.

In your main text you may want to indicate to the reader that some word or phrase appears in the glossary. For that there is the `@InGlossary` symbol:

... where you can put one `@InGlossary { object } ...`

The thing between braces does not actually have to be in the glossary; `@InGlossary` usually just changes the font, by default to small capitals, and it does not change anything unless `@MakeGlossary` is `Yes`.

The remainder of this section explains how to change the appearance of the printed glossary, by setting options in the setup file. For a general introduction to setup files and their options, see Section 4.1; here we just explain how the particular options relating to glossaries work.

Most of the glossary options appear within the `@DocumentSetup @Use` clause. Here they are (except `@GlossaryFormat` which we'll discuss in a moment) with their default values:

```
@MakeGlossary { No }
@GlossaryText { @Null }
@GlossaryFont {}
@GlossaryBreak {}
@GlossaryGap { @DisplayGap }
@GlossaryColumnNumber{ 2 }
@GlossaryColumnGap { 1.00c @OrIfPlain 6s }
@InGlossaryFont { smallcaps }
@InGlossaryFormat { @Body }
```

First comes `@MakeGlossary`, which determines whether to make a glossary, as we know.

`@GlossaryText` is some arbitrary text that will be placed before the first entry of the glossary. You can also give this option to the `@Book` and `@Report` symbols, and that would probably be the best place since such text is usually part of the document content, not the setup.

`@GlossaryFont` and `@GlossaryBreak` are font and break style options which are applied to each glossary entry. The default values don't change the font or break style at all.

`@GlossaryGap` determines the vertical separation between one glossary entry and the next. You can give any length (Section 1.2) here; the default is the gap used around displays.

`@GlossaryColumnNumber` and `@GlossaryColumnGap` determine the number of columns on glossary pages, and the width of the gap between them. By default you get two columns per page and a one centimetre gap (or six spaces in plain text output), as for indexes (Section 2.11).

`@InGlossaryFont` and `@InGlossaryFormat` determine the appearance of the result of the

@InGlossary symbol. The first changes the font; the second allows for more radical formatting. Within it, @Body stands for the object following the @InGlossary object, and you can do anything you like with it here. For example,

```
@InGlossaryFormat { @CurveBox @Body }
```

would cause @InGlossary to enclose the following object in a curvebox (which would look horrible, of course). The default values change to small capitals but nothing more.

@GlossaryFormat, which we omitted earlier because it is more complex, determines the format of each glossary entry. Here it is with its default value:

```
@GlossaryFormat {
  +3p @Font @S @Name @Right @I { @Word&&page @PageNum }
  @DP
  @RawIndentedDisplay @Body
}
```

We'll go through this bit by bit.

First, the value of the option is longer than usual so we have spread it over three lines. There is nothing significant in this; end of line is the same as a space to Lout, and we've used three lines just to show the value clearly.

Within @GlossaryFormat three symbols are made available specially:

@Name	Will be replaced by the term being defined
@PageNum	Will be replaced by the number of the page of the spot where the @Glossary symbol is placed
@Body	Will be replaced by the definition

Now let's look at what the default format does. The first bit,

```
+3p @Font @S @Name
```

produces the term being defined, three points larger than would have been the case otherwise, and in small capitals. The @Right symbol causes what follows it to appear at the far right, so

```
@I { @Word&&page @PageNum }
```

will appear at the right of the column on the same line as the term. The value of @Word&&page is just page in the current language, and @PageNum is a page number as we know, so this produces something like

page 143

at the right. After that we have @DP which leaves a display-sized vertical gap, then the body appears in an indented display, made Raw so that there is no trailing vertical space.

You can change this option to anything you like. For example, suppose you prefer bold to small capitals, you want the page number in parentheses after the term, and you want each entry

to be kept together in one column:

```
@GlossaryFormat {
  @OneRow {
    @B @Name (@I { @Word&&page @PageNum })
    @DP
    @RawIndentedDisplay @Body
  }
}
```

And so on.

There are a few more setup file options for glossaries, to be found in the @BookSetup or @ReportSetup @Use clause of the setup file. Here they are with their default values:

```
@GlossaryWord { glossary }
@GlossaryInContents { Yes }
@GlossaryPrefix { }
```

The first determines the word that will be used as the title of the glossary. The default value shown produces Glossary in English and its equivalent in other languages. You could change it, for example, to

```
@GlossaryWord { List of Definitions }
```

@GlossaryInContents determines whether the glossary will be listed in the table of contents if there is one; and @GlossaryPrefix is used by structure page numbers.

2.11. Indexes

Although Lout is not clever enough to guess what entries should go in your index, it will do almost everything else for you: sort the entries and attach the correct page numbers automatically. As for tables of contents, the default setting is to have an index in books but not in other types of documents. This and a few aspects of the appearance of the index can be changed by changing the setup file, as explained at the end of this section.

Now, suppose you are discussing Galileo and you want his name in your index. Let's be ambitious and say that you want the index to contain something like this:

```
Galileo Galilei
  life of, 201
  telescope, his use of, 201–203
  trial of, 205–211, 242, 395
```

These lines show off Lout's five tricks: the first is a *raw entry* (no page number attached); the second is a *sub-entry* (indented); the third has a *page number range* instead of a single page number; and the fourth has a *merged entry* (several page numbers or ranges within one entry) and a *special element* (the page number in italics).

We'll get to them in a moment, but first, let's see how to get a basic entry, like this one:

Galileo Galilei, 201

To get this into your index, type

```
galileo @Index { Galileo Galilei }
```

at the point where you mention Galileo. Nothing will be printed there, but the object following the @Index symbol will be placed in the index, with a comma and the correct page number appended automatically.

The object preceding the @Index symbol is a compulsory key which is used for sorting the index entries,¹ but which is not itself printed anywhere. It is best to construct these sorting keys from lower-case letters and the . character only, beginning with a letter, although multi-word keys are allowed. These sorting keys do not have to be distinct from the tags used in cross referencing; however, they do have to be distinct from each other, unless you want merged entries (see below).

Our first trick, raw entries (no page number attached), is very easy: just use @RawIndex instead of @Index. So the first line of our ambitious example is obtained by

```
galileo @RawIndex { Galileo Galilei }
```

This could go anywhere, since no page numbers are involved.

Our second trick, sub-entries, is also very easy, since a sub-entry differs from an ordinary entry only by having an indent. The symbol is @SubIndex, so the second line of our ambitious example is produced by

```
galileo.life @SubIndex { life of }
```

You should always give sub-entries the same sorting key as their corresponding main entries, plus a . and another word, because then you can be certain that the sorting will place sub-entries directly after their main entries. There is a @SubSubIndex symbol that produces a double indent, and there are @RawSubIndex and @RawSubSubIndex symbols.

For our third trick, page number ranges, we use the to option of the @Index, @SubIndex, and @SubSubIndex symbols. For example, to produce the sub-entry

```
telescope, his use of, 201–203
```

put

```
galileo.telescope @SubIndex to { gt.end } { telescope, his use of }
```

¹The collating sequence used to decide what comes after what is either the collating sequence used by the memcmp() library routine (just the underlying binary character codes), or else the one used by the strcoll() collating sequence, which understands accented characters and whose effect depends on your locale. To find out whether strcoll() is in use or not, type `lout -V` which prints out several lines of this and similar information, including information about command line flags to switch between the two kinds of collation.

If the sorting you get turns out to be not what you expected, the first thing to try is the replacement of all accented letters in index keys by unaccented ones. Sorting is quite an intractable problem: even if strcoll() gets the sorting right for one language, there still remains the problem of sorting multilingual indexes.

at the beginning of the range, and

```
@PageMark { gt.end }
```

at the end. You can use any tag you like inside the `to` option, as long as it differs from every other tag (notice that sorting keys do not have to differ from tags, but `to` options do: this is because `to` options go into `@PageMark` like other tags do, and if two tags are the same we would have an ambiguous result of `@PageOf`). If both ends of the range fall on the same page, the `to` option is ignored: you will never get 201–201.

Our fourth trick is the merged entry:

```
trial of, 205–211, 242, 395
```

The main thing to grasp is that this merged entry was originally three separate entries (sub-entries in this case):

```
trial of, 205–211
trial of, 242
trial of, 395
```

We already know how to produce these three entries, using three `@SubIndex` symbols, one with a `to` option. Now we have discovered that `Lout` is able to merge several entries into one entry. This raises two questions: how does `Lout` know which entries to merge? and given those entries, what does the merging produce?

The answer to the first question is that `Lout` merges entries whose sorting keys are equal. The merged entry above is produced by these three entries, placed in the appropriate places:

```
galileo.trial @SubIndex to { gtrial.end } { trial of }
galileo.trial @SubIndex { trial of }
galileo.trial @SubIndex { trial of }
```

The entries are merged because they have the same sorting key (`galileo.trial`), not because they happen to have the same content (`trial of`). In fact, once the page numbers are added the content is not the same at all.

Now, having decided that the three entries

```
trial of, 205–211
trial of, 242
trial of, 395
```

must be merged, what does `Lout` do? Without being too formal, it finds the shortest larger entry that contains everything in the given entries, more or less, preserving the order in which the entries' points of origin appear in the final printed document.

If the entries are not different at all, then the result will be the same as each of them. With this in mind, let us return to our initial, ambitious example:

Galileo Galilei
 life of, 201
 telescope, his use of, 201–203
 trial of, 205–211, 242, 395

We now know how to produce all four of these entries, but one problem of some practical importance remains. Suppose we delete the section on the life of Galileo. If we had put the entry that produces ‘Galileo Galilei’ in that section, we might inadvertently delete it, and the other two sub-entries will lose their main entry. Before deleting anything, we must hunt through it for index entries and ponder their significance, an error-prone and time-wasting thing to do.

The solution is as follows. When an index entry has sub-entries, make it raw, and repeat it just before each of its sub-entries:

```
galileo @RawIndex { Galileo Galilei }
galileo.life @SubIndex { life of }
```

at the first place,

```
galileo @RawIndex { Galileo Galilei }
galileo.telescope @SubIndex { telescope, his use of }
```

at the second, and so on. Now it is easy to verify that every sub-entry has a main entry; and when deleting a sub-entry we can and should delete the adjacent main entry. After sorting, our index entries will be

galileo	Galileo Galilei
galileo	Galileo Galilei
galileo	Galileo Galilei
galileo	Galileo Galilei
galileo	Galileo Galilei
galileo.life	life of, 201
galileo.telescope	telescope, his use of, 201–203
galileo.trial	trial of, 205–211
galileo.trial	trial of, 242
galileo.trial	trial of, 395

The first five entries have the same sorting key, and will be merged as required.

Each index entry symbol has a `pnformat` option, which affects the way the page number of the entry is printed in the index. For example,

```
galileo.trial @SubIndex pnformat { Main } { trial of }
```

indicates that this is an entry of format `Main`. By default the format is `Ordinary`; it may be `Main`, producing a bold page number in the index, or `Special`, producing an italic page number.

As the name suggests, the `pnformat` option is actually a format option, within which the `@PageNum` symbol stands for the index page number, so you could even write

```
galileo.trial @SubIndex pnformat { @Underline @PageNum } { trial of }
```

to get an underlined page number. However, it is rarely a good idea to use the `pnformat` option in this way. Better to decide once and for all what variants on the basic format you are going to have, call one variant `Main` and the other `Special`, use the setup file options described later in this section to redefine the appearance of page numbers for these two index entry formats, and explain in the `@IndexText` what the formats mean.

When index entries with different formats are merged, naturally each page number preserves its own format. If there are two merged entries with the same page number but different formats, the result is plausible but indeterminate. A page number range is formatted according to the format of the index entry which is its starting point. To change the format of the *stem* of the index entry, just do the usual thing. For example,

```
galileo @Index @I { Galileo Galilei }
```

will cause the stem of the entry to appear in an italic font.

The language of the index entry will be the initial language of the document as a whole, which is not necessarily the language at the point where the index entry occurs. To get the correct language you will need a `@Language` symbol following the `@Index` symbol:

```
galileo. @Index Italian @Language { Galileo Galilei }
```

or whatever. If you don't do this your index entry might be hyphenated incorrectly.

Although the page numbers in index entries will be kept up to date automatically as the document changes, as all cross references are, it is best to refrain from inserting index entries until the document is complete and an overall plan of the structure of the index can be made. Place index entries for floating figures and tables within their captions.

Large indexes may benefit from *spacers* – empty spaces or even headings between the parts for each letter of the alphabet. One simple way to get blank line spacers is with `@RawIndex`, like this:

```
b @RawIndex {}
c @RawIndex {}
d @RawIndex {}
...
z @RawIndex {}
```

These phantom entries will insert blank lines before the region of each English letter except 'a'. In fact there is a symbol called `@IndexBlanks` that makes exactly these 25 entries. Unfortunately, these blanks will occasionally appear at the top of a column, and if there are no tags beginning with `x`, for example, there will be two blank lines between the `w` and `y` entries. You can start off with `@IndexBlanks` and replace it later by the appropriate subset, if necessary.¹

A more elaborate kind of spacer can be placed into the index with the `@IndexSpacer` symbol, like this:

¹For Lout to solve this problem automatically, it would need to be told which letter each index entry belongs under, perhaps by symbols `@AIndex`, `@BIndex`, etc. The author felt that this would have been too tedious.

a @IndexSpacer A

This is roughly equivalent to a @RawIndex A in that it puts the entry A at sort position a; but it also places extra space above and below it, and it includes a font change, so that the A stands out like a heading (you can see the effect in the index of this document). @IndexSpacer also includes a conditional new page effect, so that the spacer never appears alone at the bottom of a column.

You need to change things slightly for the first spacer:

a @InitialIndexSpacer A

to tell Lout to omit the unwanted space above it. There is an @IndexLetters symbol which places the 26 spacers

a @InitialIndexSpacer A

b @IndexSpacer B

...

z @IndexSpacer Z

into your document for you in one go. Users of other alphabets are recommended to define a similar symbol of their own.

The remainder of this section describes how to change the appearance of the index by setting options in the setup file. For setup files and their options in general, consult Section 4.1.

There are several setup file options for the index. Here they are with their default values:

```
@MakeIndex { No }
@IndexText { @Null }
@IndexFont { }
@IndexBreak { oragged 1.2fx }
@IndexFormat { @Body }
@SubIndexFormat { {1f @Wide}@Body }
@SubSubIndexFormat { {2f @Wide}@Body }
@IndexTypeOrdinary { @PageNum }
@IndexTypeMain { @B @PageNum }
@IndexTypeSpecial { @I @PageNum }
@IndexRangeFormat { @From--@To }
@IndexColumnNumber { 2 }
@IndexColumnGap { 1.00c }
@IndexCtd { Yes }
@IndexCtdWord { continued }
@IndexCtdFormat { @Body @I (@CtdWord) }
@IndexSpacerAbove { 2v }
@IndexSpacerBelow { 1v }
@IndexSpacerFont { +3p }
@IndexSpacerFormat { @Body }
```

The @MakeIndex option, which may be Yes or No, determines whether to produce an index

or not. Although the default value is No, any type of document may be given an index just by changing it to Yes. This has already been done in the book setup file, but not in the others.

@IndexText is some text to put at the start of the index, after the heading but before any index entries. It will appear full width on the page. This option is also available as an option of the @Document, @Report, and @Book symbols.

@IndexFont determines the font and font size of index entries (e.g. Times Base 12p). Leaving it empty as above produces the same font as the rest of the document. @IndexBreak is the paragraph breaking style applied to index entries; oragged is the traditional and best way.

@IndexFormat allows a more radical control of the appearance of the index entry than just its font and break style. Within it, the @Body symbol stands for the entry, not including any page numbers. The default value just leaves the index entry as is, but the corresponding options for formatting subindexes (@SubIndexFormat and @SubSubIndexFormat) are more interesting:

```
@SubIndexFormat { {1f @Wide}@Body }
```

causes subindexes to begin with an indent of width 1f, immediately followed by the entry. For more information about lengths like 1f, see Section 1.2. Another possible format is

```
@SubIndexFormat { -- @Body }
```

which causes the subindex to begin with an en-dash and two spaces instead of an indent.

@IndexTypeOrdinary, @IndexTypeMain, and @IndexTypeSpecial give the page number format to use when the index entry type is Ordinary, Main, and Special respectively. Within them the @PageNum symbol stands for the page number or page number range being printed. The value of these options can be an arbitrary object. If the value of a pformat option is not Ordinary, Main, or Special, then the pformat option itself is printed; it too may contain a @PageNum symbol, as explained earlier.

@IndexRangeFormat gives the format to use when a page number range, such as 5–8, is to be included in an index entry. Within it the symbols @From and To stand for the first and last page numbers respectively. These will always be different when @IndexRangeFormat is used; Lout knows never to insert a range when the two end points are equal. The default value just separates the two numbers by an en-dash with no space.

@IndexColumnNumber and @IndexColumnGap determine the number of index columns per page, and the gap between them, and are exactly analogous to the @ColumnNumber and @ColumnGap options described in Section 2.12.

The next three options work together to control the appearance of running headers¹ in the index:

```
@IndexCtd { Yes }
@IndexCtdWord { continued }
@IndexCtdFormat { @Body @I (@CtdWord) }
```

¹Owing to problems behind the scenes, if more than three copies of the same running header appear on the same page, their horizontal positions will become confused, probably resulting in the apparent disappearance of all but the last three. Of course, this is highly unlikely to happen, since it means there must be a four-column index with a page on which all four columns have the same running header.

If an `@Index` entry has `@SubIndex` entries that run over to the next column, Lout will print an unobtrusive running header at the top of that column, something like this in English:

```
procrastination (ctd.)
```

It will print two running headers if a `@SubIndex` entry has `@SubSubIndex` entries that run over, one for the main entry and an indented one for the sub-entry. You can turn off these running headers by setting `@IndexCtd` to `No`. A particular word is associated with index running headers; by default it is `ctd.` in English and its equivalent in other languages. This is what the default value, `continued`, of the `@IndexCtdWord` option gives you; if you want some other word, change that option to the word you want. Finally, you can control the format of the running headers using `@IndexCtdFormat`. Within this option, the symbol `@Body` stands for the value of the index entry that is running over (as formatted by `@IndexFormat`, `@SubIndexFormat`, or `@SubSubIndexFormat` but without any page numbers), and `@CtdWord` stands for the word produced by the `@IndexCtdWord` option. The default value of `@IndexCtdFormat`, shown above, yields the index entry followed by `@IndexCtdWord` in italics and parentheses.

Finally, we have four options to control the appearance of index spacers:

```
@IndexSpacerAbove { 2v }
@IndexSpacerBelow { 1v }
@IndexSpacerFont { +3p }
@IndexSpacerFormat { @Body }
```

`@IndexSpacerAbove` and `@IndexSpacerBelow` determine the amount of extra space to insert above and below index spacers (except that `@InitialIndexSpacer` uses `0v` for its above space). Any lengths from Section 1.2 are acceptable here; the default lengths shown are two times and one times the current inter-line spacing. `@IndexSpacerFont` may contain any font change acceptable to the `@Font` symbol; the default increases the size by 3 points. For more radical changes to the spacer format, `@IndexSpacerFormat` allows any symbols to be applied to the spacer object, which is represented by the symbol `@Body` within this option. For example,

```
@IndexSpacerFormat { @Underline @Body }
```

will cause the spacer to be underlined.

The `@IndexSpacer` symbol has `above`, `below`, `font`, and `format` options which override the four setup file options. For example, `@InitialIndexSpacer` is equivalent to

```
@IndexSpacer above { 0v }
```

Whether you will ever need to vary the appearance of index spacers individually in this way is very doubtful, but the capacity is there.

Lout offers the possibility of having up to three independent indexes (useful for author indexes, etc.). The other two are called index A and index B, and they precede the main index in the output. Just replace `Index` by `IndexA` to refer to index A, and by `IndexB` to refer to index B. For example,

```
smith.j @IndexA { Smith, John }
```

will insert an index entry to index A, and @IndexBBlanks will insert the usual 25 blank entries into index B. There are setup file options to change the titles of indexes.

In large projects it might help to rename the @IndexA symbol to something else, such as @AuthorIndex. This can be done by placing

```
import @DocumentSetup
macro @AuthorIndex { @IndexA }
```

in the mydefs file. See Section 2.13 for an introduction to the mydefs file; the word macro is needed here instead of def because we are introducing a new name for an existing symbol, not defining a new symbol.

2.12. Multiple columns

You can change the number of columns of text per page, and the width of the gap between the columns, by changing these two setup file options:

```
@ColumnNumber { 1 }
@ColumnGap { 1.00c }
```

If you are using your own setup file (Section 4.1), you can find and change them there. If not, @ColumnNumber may be changed at the beginning of your document (Section 3.1).

@ColumnNumber may be any number between 1 and 10, with default value 1 as shown, and @ColumnGap may be any length (Section 1.2). The column width is derived from these options using the obvious formula

$$columnwidth = \frac{pagewidth - margins - (@ColumnNumber - 1) \times @ColumnGap}{@ColumnNumber}$$

You must ensure that this comes to something reasonable.

These two options do not apply to pages containing an index. For them there are similar setup file options called @IndexColumnNumber and @IndexColumnGap (Section 2.11).

Most document types permit you to have multiple columns, but certain things will be kept full width regardless of the @ColumnNumber option: figures and tables, chapter headings, and so on. The details vary with the document type, so are deferred to Chapter 3.

2.13. Defining new symbols

Whenever you find yourself typing the same thing repeatedly, you can save a lot of time by defining your own personal symbol to stand for that thing. For example, suppose you type your company's name, Batlow Food Distributors Pty. Ltd., frequently. You can define your own symbol, @Batlow say, so that

Concerning your crate supply contract with @Batlow, @Batlow wishes to ...

produces

Concerning your crate supply contract with Batlow Food Distributors Pty. Ltd., Batlow Food Distributors Pty. Ltd. wishes to ...

You will never have to type Batlow Food Distributors Pty. Ltd. again.

The method is to create a file called `mydefs` in your current directory, containing definitions like this:

```
import @BasicSetup
def @Batlow { Batlow Food Distributors Pty. Ltd. }
```

The meaning of the first line, `import @BasicSetup`, will be explained shortly. After that comes `def` for ‘define,’ then the name of the symbol being defined, then its value between braces. So this example defines a symbol called `@Batlow` to stand for the object following it between braces. Lout will read this file during its setup phase (Section 4.1). Alternatively, you can place definitions directly into your document files, following your `@SysInclude` lines and before `@Doc`, `@Report`, or whatever symbol your document proper starts with.

Your symbols may have any names you wish made from letters and `@`. However, it is good practice to have exactly one `@`, at the start, and to choose distinctive names that have no chance of being the same as the name of any existing symbol. `@Batlow` is a good choice, for example.

The object between braces is quite arbitrary; in particular, it may contain symbols. For example, suppose you frequently need a small grey box:

```
import @BasicSetup
def @GreyBox { @Box paint { lightgrey } {} }
```

This defines a `@GreyBox` symbol that produces `□`. Most of the symbols in this guide are from the *BasicSetup package*, which is why `import @BasicSetup` is required: it makes these symbols available to the definition, and can actually be omitted before definitions like the one for `@Batlow` which do not use any symbols. However it does no harm, so we place it in front of every definition as a matter of course.¹

Now suppose you frequently need a grey box, but enclosing different things: `ENTRY` one moment, `EXIT` the next. You could try omitting the `{}` from the definition above, but that does not work, because Lout notices the missing object while reading the definition, and inserts an empty object in the usual way (Section 1.5).

However, there is a way to define a `@GreyBox` symbol so that `@GreyBox ENTRY` produces `ENTRY`, `@GreyBox EXIT` produces `EXIT`, and so on:

```
import @BasicSetup
def @GreyBox right x { @Box paint { lightgrey } x }
```

The addition of `right x` immediately after the symbol’s name places `@GreyBox` into that class of symbols, like `@l` and `@Box`, which consume and transform the object to their right. The `x` in `right x` means that the object to the right will be referred to as `x` within the definition. So in

¹ Later chapters of this guide introduce specialized symbols for producing tables, equations, diagrams, graphs, and computer programs. You need a different import clause when using those symbols within a definition, because they are not from the *BasicSetup package*. Examples may be found in the chapters concerned.

```
@GreyBox { Hello world }
```

@GreyBox consumes the following object, which becomes x, so that the value is

```
@Box paint { lightgrey } { Hello world }
```

which produces `Hello world`.

It is a good principle to choose symbol names that refer to what the symbol is for, rather than how it does what it does. Here is a good example:

```
import @BasicSetup
def @Poetry right x { lines @Break @| x }
```

This kind of name is very pleasant to use, since it allows you to forget about what is going on behind the scenes:

```
@IndentedDisplay @Poetry {
  Teach me to hear Mermaides singing,
  Or to keep off envies stinging,
    And finde
    What winde
  Serves to'advance an honest minde.
}
```

Most of Lout's symbols follow this principle.

You can define symbols that consume the object to their left as well as the object to their right, as the @Font, @Break, and @Colour symbols do:

```
import @BasicSetup
def @HeadingBox left x right y
{ @Box { @CentredDisplay @Heading x y }
}
```

This definition occupies several lines only because it is long; as usual, end of line is the same as one space. Now

```
Cheating @HeadingBox {
  The Department uses assignments ... of that student alone.
}
```

is much easier to type than the equivalent example in Section 8.3. The result is the same:

Cheating

The Department uses assignments both as a teaching device and as a major component of its assessment of each student. It therefore requires that all programs, exercises etc. handed in bearing an individual student's name be the work of that student alone.

Do not use a paragraph, display, or list symbol at the beginning or end of a definition, since the result is not what people who do it are hoping for.

Chapter 3. Types of Documents

Particular types of documents have specialized formatting requirements: title pages in books, abstracts in technical reports, and so on. Lout provides a range of *document types* with the appropriate specialized features for each type.

There are five types: ordinary documents, technical reports, books, overhead transparencies, and stand-alone illustrations. The features of all other chapters are available within each document type, but the features of one type are not available within other types.

3.1. Ordinary documents

Ordinary documents are the simplest kind, consisting of a plain sequence of numbered pages. To produce an ordinary document, use the doc setup file and the @Doc symbol:

```
@SysInclude { doc }
@Doc @Text @Begin
...
@end @Text
```

where ... stands for the body of your document. This is the arrangement from Section 1.1 for getting started. Alternatively, you can begin with @Document instead of @Doc:

```
@SysInclude { doc }
@Document
@InitialFont { Times Base 12p }
@InitialBreak { adjust 1.2fx hyphen }
@InitialSpace { lout }
@InitialLanguage { English }
@PageOrientation { Portrait }
@PageHeaders { Simple }
@FirstPageNumber { 1 }
@ColumnNumber { 1 }
@OptimizePages { No }
@Unpaginated { No }
//
@Text @Begin
...
@end @Text
```

This shows all the options of @Document, with their default values. As usual with options, the options of @Document may be given in any order, and only the ones that need to be changed need be given at all. Notice the // after the last option. Its meaning is beyond our scope, but total disaster will ensue if it is forgotten. The @Doc symbol is an abbreviation for @Document //,

which is why you don't need // with @Doc.

The eight options are a selection of setup file options (Section 4.1) that frequently need to be changed. If your changes to the overall formatting are confined to these options, you can change them here and avoid having your own setup file. If you already have your own setup file, change them in either place and omit them in the other.

@InitialFont is the font of the bulk of the document, and should contain a family, a face, and a size. The default value selects the Times family, the Base face, and the 12 point size.

@InitialBreak controls the behaviour of paragraph breaking in the bulk of the document. It should have three parts: a paragraph breaking style (adjust, ragged, etc.), an inter-line spacing (1.2fx for single spacing, 2.4fx for double spacing, and so on), and either hyphen or nohyphen for turning hyphenation on or off. It may also have nobreakfirst or nobreaklast (or both), meaning to disallow a page break after the first line of a paragraph, or before the last, respectively.

@InitialSpace determines how Lout treats white space between two objects, as described in Section 1.19. @InitialLanguage determines the language of the bulk of the document.

@PageOrientation determines the orientation of the page. Its value may be Portrait (the default), Landscape, ReversePortrait, or ReverseLandscape. See Section 4.2 for further details.

@PageHeaders determines the appearance of page headers and footers throughout the document, and may be None, Simple, Titles, or NoTitles. Section 4.4 has the details, but just briefly, None means no page headers at all, Simple means a page number between hyphens at the top of each page except the first, Titles produces full running titles as in this guide, and NoTitles is like Titles with the running titles omitted, leaving just the page numbers.

@FirstPageNumber is the page number given to the first page.

@ColumnNumber is the number of columns per page in the bulk of the document, and may be anything from 1 (the default value) to 10. It is possible to produce full-width ordinary text in a multi-column document, using the @FullWidth symbol:

```
@SysInclude { doc }
@Document
  @ColumnNumber { 2 }
//
@Text @Begin
@FullWidth {
@CentredDisplay @Heading { NOTICE TO TRESPASSERS }
}Trespassers are hereby notified that, ...
@end @Text
```

This produces a full-width heading above a two-column body. The word Trespassers has been placed immediately after the closing brace of @FullWidth because (regrettably) any space here will appear before Trespassers in the output. Alternatively you could use a paragraph symbol:

```
@FullWidth {
@CentredDisplay @Heading { NOTICE TO TRESPASSERS }
}
@PP
Trespassers are hereby notified that, ...
```

You can have several `@FullWidth` symbols, producing full-width text wherever you want. Just be aware that `@FullWidth` always causes a fresh page to be begun, it will never appear on the same page as a figure or table, and it is not able to hold a table of contents, a section, or an appendix.

Lout ordinarily places lines onto a page until space runs out, then moves to the next page and so on. This often produces ugly empty spaces at the bottoms of pages preceding large unbreakable displays. Setting the `@OptimizePages` option to `Yes` causes Lout to examine the overall situation and try to minimize the ugliness, using the `TeX` optimal paragraph breaking algorithm. It takes two runs to do this, with intermediate results stored in Lout's cross reference database (Section 2.8); so deleting file `lout.li` will reset it, which might be wise after major changes. It is possible for the optimizer to cycle, never settling on a single final best version; this is usually caused by footnotes or floating figures inserted at points that end up near page boundaries.

The `@Unpaginated` option, whose value is ignored unless plain text output is in effect, produces unpaginated output when changed to `Yes` (see Section 3.6).

Within the `@Text` symbol, it is possible to have a sequence of sections:

```
preceding text
@BeginSections
@Section ... @End @Section
@Section ... @End @Section
...
@Section ... @End @Section
@EndSections
```

as described in Section 2.7. Within any section, a similar arrangement produces subsections:

```
preceding text
@BeginSubSections
@SubSection ... @End @SubSection
@SubSection ... @End @SubSection
...
@SubSection ... @End @SubSection
@EndSubSections
```

Within any subsection, there may be sub-subsections, obtained using `@BeginSubSubSections`, `@SubSubSection`, and `@EndSubSubSections`. There are no sub-sub-subsections.

Also within the `@Text` symbol only, there may be a sequence of appendices:

```
preceding text
@BeginAppendices
@Appendix ... @End @Appendix
@Appendix ... @End @Appendix
...
@Appendix ... @End @Appendix
@EndAppendices
```

These will be 'numbered' A, B, C etc. as is conventional. Within any appendix there may be a sequence of subappendices, obtained in the usual way using `@BeginSubAppendices`,

@SubAppendix, and @EndSubAppendices. There are sub-subappendices as well, following the same pattern, but no sub-sub-subappendices.

In addition to the @Title option, each large-scale structure symbol (@Section, @SubSection, @SubSubSection, @Appendix, @SubAppendix, and @SubSubAppendix) has a @Tag option for cross referencing (Section 2.8), an @InitialLanguage option for changing the language of that part of the document, and a @RunningTitle option which will be used in place of @Title in running headers if given. @RunningTitle is useful when the full title is rather long.

The features described in other chapters are all available within ordinary documents. Endnotes and references appear automatically at the end of the document. Figures are labelled Figure 1, Figure 2, etc., and tables are labelled Table 1, Table 2, etc.

To get a table of contents, set the @MakeContents option in the setup file to Yes, and insert the symbol @ContentsGoesHere at the point where you would like the table of contents to appear, anywhere before the first section:

```
@SysInclude { doc }
@Text @Begin
@CentredDisplay @Heading { Safety Procedures }
@Heading { Contents }
@DP
@ContentsGoesHere
@DP
...
@End @Text
```

You must supply your own heading, as well as paragraph symbols before and after. Regrettably, @ContentsGoesHere may not be placed inside a display, nor inside @FullWidth.

To get an index, set the @MakeIndex option in the setup file to Yes, and follow the instructions in Section 2.11. The index will appear automatically at the end of your document.

Within the doc setup file there is an @OrdinarySetup symbol whose options control the appearance of features specific to ordinary documents (in other words, the features described in this section). Here is a representative sample of these options, showing their default values:

```
@Use { @OrdinarySetup
# @IndexWord { index }
# @AppendixWord { appendix }
# @SectionNumbers { Arabic }
# @SectionHeadingFont { Bold }
# @SectionGap { 2.00v }
# @SectionInContents { Yes }
# @SectionContentsIndent { 0f }
}
```

Section 4.1 explains how to make your own setup file and change its options.

The @IndexWord option determines what the index is called, if there is one. The default value, index, produces the word ‘Index’ in the current language. Any other value produces itself. The @AppendixWord option is similar; its default value is ‘Appendix’ in the current language.

`@SectionNumbers` determines how sections will be numbered, and may be `None`, `Arabic`, `Roman`, `UCRoman`, `Alpha`, or `UCAAlpha`. The default value is `Arabic` for sections and also all other large-scale structure symbols except appendices, for which it is `UCAAlpha`. This produces the appendices numbered in upper-case letters (A, B, C, etc.) that were mentioned earlier.

`@SectionHeadingFont` is the font used for section headings. The default value produces the bold face from the family of the initial font. A family name or size is also acceptable:

```
@SectionHeadingFont { Helvetica Base +2p }
```

makes the section heading appear in the Helvetica font, two points larger than the initial size.

`@SectionGap` determines how much space is left blank before each section title; the default value shown above is twice the current inter-line spacing. The special value `2b` may be used to get a page break rather than a space. There are similar options for other large-scale structure symbols, which determine how much space is left before each one.

`@SectionInContents` determines whether or not an entry is made in the table of contents for each section; it may be `Yes` or `No`, but would always be `Yes`. The default value of the corresponding options for sub-subsections and sub-subappendices, however, is `No`. `@SectionContentsIndent` determines the indent of the contents entry if printed at all; the default value shown above, `0f`, asks for zero indenting, so the entry will appear at the left margin.

3.2. Technical reports

To make a technical report, start off with the report setup file and the `@Report` symbol:

```

@SysInclude { report }
@Report
  @Title {}
  @Author {}
  @Institution {}
  @DateLine { No }
  @AtEnd {}
  @CoverSheet { Yes }
  @ContentsSeparate { No }
  @InitialFont { Times Base 12p }
  @InitialBreak { hyphen adjust 1.2fx }
  @InitialSpace { lout }
  @InitialLanguage { English }
  @PageOrientation { Portrait }
  @PageHeaders { Simple }
  @ColumnNumber { 1 }
  @FirstPageNumber { 1 }
  @OptimizePages { No }
  @AbstractDisplay { Yes }
  @AbstractTitle { Abstract }
  @Abstract {}
  @GlossaryText { @Null }
  @IndexText { @Null }
  @IndexAText { @Null }
  @IndexBText { @Null }
//

```

This shows all the options of `@Report`¹ with their default values. As usual with options, they may be given in any order, and only the ones whose values need to be changed need be given at all. The meaning of the `//` symbol is beyond our scope, but disaster will ensue if it is forgotten.

The `@Title` option holds the title of the report. It will be printed using the clines paragraph breaking style (Section 1.9), which centres each line, so it makes sense to have multi-line titles:

```

@Report
  @Title {
The solution of real instances of
the timetabling problem
}
...

```

With a multi-line title, each line after the first should begin at the left margin, not indented. It doesn't matter where the first line begins, because space following an open brace is ignored.

The `@Author` and `@Institution` options hold the author's name and institution or address, and will also be printed using the clines style. If there are several authors but only one institution, list all the authors in the `@Author` option:

¹Before Version 3.13, `@Abstract` followed `//` rather than preceded it, and had some options that are now withdrawn. Old documents may therefore need some superficial rearrangement.

@Author { Tim B. Cooper and Jeffrey H. Kingston }

With more authors, or with more than one institution, it is best to ignore the @Institution option and place all the information within the @Author option, enclosing institution information in @I symbols. In extreme cases, a table with columns of authors might be necessary (Chapter 6).

@DateLine may be set to No, meaning no dateline, Yes, meaning print the current date, or anything else, which is taken to be a date and printed:

@DateLine { 4 July, 1776 }

A good plan is to use @DateLine { Yes } until the report is finalized.

The @AtEnd option will come out on a single unnumbered page with no page headers or footers, and using the same margins as for even pages, after the very last page of the report; even after the index if there is one. It is intended to make it possible to include a back cover, so @PageOf last.page does not take account of any @AtEnd page.

The remaining options (except @Abstract) are setup file options (Section 4.1) that frequently need to be changed. If your changes to the overall formatting are confined to these options, you can change them here and avoid having your own setup file. If you already have your own setup file, change them in either place and omit them in the other.

If @CoverSheet is Yes, an unnumbered cover sheet will be produced containing the title, author, institution, abstract, and dateline. Otherwise they will appear on the first page. The ‘cover sheet’ is in reality a sequence of Intro pages (Section 4.4), numbered by default with Roman numerals on pages after the first.

In order to get a table of contents, it is necessary to use your own setup file (Section 4.1 explains how to do this) and to set the @MakeContents option within it to Yes. The table of contents will ordinarily appear beginning on the first page, but if the @ContentsSeparate option of @Report is set to Yes it will appear on separate pages.

@InitialFont is the font of the bulk of the report, and should contain a family, a face, and a size. The default value selects the Times family, the Base face, and the 12 point size.

@InitialBreak controls the behaviour of paragraph breaking in the bulk of the report. It should have three parts: a paragraph breaking style (adjust, ragged, etc.), an inter-line spacing (1.2fx for single spacing, 2.4fx for double spacing, and so on), and either hyphen or nohyphen for turning hyphenation on or off. It may also have nobreakfirst or nobreaklast (or both), meaning to disallow a page break after the first line of a paragraph, or before the last, respectively.

@InitialSpace determines how Lout treats white space between two objects, as described in Section 1.19. @InitialLanguage determines the language of the bulk of the report.

@PageOrientation determines the orientation of the page. Its value may be Portrait (the default), Landscape, ReversePortrait, or ReverseLandscape. See Section 4.2 for further details.

@PageHeaders determines the appearance of page headers and footers. Its value may be None, Simple, Titles, or NoTitles. Section 4.4 has the details, but just briefly, None produces no page headers, Simple produces a centred page number between hyphens on every page except the cover sheet and the first page, Titles produces full running titles as in the present document, and NoTitles is like Titles with the running titles omitted, leaving just the page numbers.

@ColumnNumber is the number of columns per page in the bulk of the report, and

may be anything from 1 (the default value) to 10. However, there is nothing analogous to the `@FullWidth` symbol of ordinary documents. Instead, the cover sheet, title material, and all figures and tables will be printed full width, and the rest will be set in columns. There is a separate `@IndexColumnNumber` option in the setup file which determines the number of columns in the index (Section 2.11).

`@FirstPageNumber` is the page number given to the first page.

Lout ordinarily places lines onto a page until space runs out, then moves to the next page and so on. This often produces ugly empty spaces at the bottoms of pages preceding large unbreakable displays. Setting the `@OptimizePages` option to `Yes` causes Lout to examine the overall situation and try to minimize the ugliness, using the \TeX optimal paragraph breaking algorithm. It takes two runs to do this, with intermediate results stored in Lout's cross reference database (Section 2.8); so deleting file `lout.li` will reset it, which might be wise after major changes. It is possible for the optimizer to cycle, never settling on a single final best version; this is usually caused by footnotes or floating figures inserted at points which end up near page boundaries.

Finally we have three options that control the abstract. `@AbstractDisplay` may be `Yes` or `No`; it determines whether the abstract is displayed (occupying the full page width except for an indent at each side like a quoted display) or inline (occupying the column width). There is a more general option, `@AbstractFormat`, in the setup file that offers more formatting choices. `@AbstractTitle` is the title of the abstract; its default value is `Abstract` or its equivalent in the current language. Finally, `@Abstract` contains the abstract itself; it may be empty or absent, in which case there will be no abstract. The abstract may contain footnotes in the usual way.

The `@GlossaryText`, `@IndexText`, `@IndexAText`, and `@IndexBText` symbols allow you to insert some arbitrary text after the title of the glossary, index, etc., and before the entries.

After the compulsory `//` comes the report body in the form of a sequence of sections:

```
@Section
  @Title { Introduction }
@Begin
@PP
...
@End @Section
```

No `@BeginSections` or `@EndSections` symbols are needed. The general rule is that you need these bracketing symbols only when you are inside something else. Sections lie inside `@Text` in ordinary documents, but they don't lie inside anything else in technical reports.

A section may have subsections, between `@BeginSubSections` and `@EndSubSections`:

```
preceding text
@BeginSubSections
@SubSection ... @End @SubSection
@SubSection ... @End @SubSection
...
@SubSection ... @End @SubSection
@EndSubSections
```

Within each subsection there may be sub-subsections, each introduced by `@SubSubSection`,

with the whole sequence bracketed by `@BeginSubSubSections` and `@EndSubSubSections`:

```
preceding text
@BeginSubSubSections
@SubSubSection ... @End @SubSubSection
@SubSubSection ... @End @SubSubSection
...
@SubSubSection ... @End @SubSubSection
@EndSubSubSections
```

There are no sub-sub-subsections.

After the sections comes an optional sequence of appendices:

```
@Appendix
  @Title { Derivation of the renewal formula }
@Begin
@PP
...
@End @Appendix
```

No `@BeginAppendices` or `@EndAppendices` symbols are needed, because (like the sections above) these appendices do not lie inside any other large-scale structure symbol. The appendices are numbered A, B, C, etc., as is conventional for them. Within each appendix there may be a sequence of subappendices, obtained with the `@SubAppendix` symbol and bracketed by `@BeginSubAppendices` and `@EndSubAppendices`:

```
preceding text
@BeginSubAppendices
@SubAppendix ... @End @SubAppendix
@SubAppendix ... @End @SubAppendix
...
@SubAppendix ... @End @SubAppendix
@EndSubAppendices
```

There are sub-subappendices following the same pattern, but no sub-sub-subappendices.

The report ends with the last section or appendix; any reference list or index will be appended automatically. Although we have described how to create reports as though everything was in one large file, in practice it is much better to divide the report into multiple files, following the method given in Section 3.8.

In addition to the `@Title` option, each large-scale structure symbol (`@Section`, `@SubSection`, `@SubSubSection`, `@Appendix`, `@SubAppendix`, and `@SubSubAppendix`) has a `@Tag` option for cross referencing (Section 2.8), an `@InitialLanguage` option for changing the language of that part of the document, and a `@RunningTitle` option which will be used in place of `@Title` in running headers if given. `@RunningTitle` is useful when the full title is rather long.

The features described in other chapters are all available within technical reports. To get a table of contents, change the `@MakeContents` option in the setup file to `Yes`; the rest is automatic, and you don't need the `@ContentsGoesHere` symbol from ordinary documents. To get an index,

again you need only change the `@MakeIndex` setup file option to `Yes`. Endnotes and references appear at the end of the report. Figures and tables are numbered 1, 2, 3, etc.

Within the report setup file there is a `@ReportSetup` symbol whose options control the appearance of features specific to reports (in other words, the features described in this section). Section 4.1 explains setup files and their options in general; here is a representative sample of these options, showing their default values:

```
@Use { @ReportSetup
# @CoverSheet { Yes }
# @DateLine { No }
# @ReferencesBeforeAppendices { No }
# @AbstractWord { abstract }
# @ContentsWord { contents }
# @SectionNumbers { Arabic }
# @SectionHeadingFont { Bold }
# @SectionGap { 2.00v }
# @SectionInContents { Yes }
# @SectionContentsIndent { 0f }
}
```

`@CoverSheet` and `@DateLine` are as for `@Report`; you can set them in either place as you prefer. `@ReferencesBeforeAppendices` determines whether the reference list is printed out before or after any appendices. `@AbstractWord` determines the value of the title of the abstract if none is given there; its default value, `abstract`, produces ‘Abstract’ in the current language. `@ContentsWord` is similar; its default value produces ‘Contents’ in the current language. The other four options control the appearance of sections, and there are similar options for controlling the other large-scale structure symbols.

`@SectionNumbers` determines how sections will be numbered, and may be `None`, `Arabic`, `Roman`, `UCRoman`, `Alpha`, or `UCAAlpha`. The default value is `Arabic` for sections, and also for all large-scale structure symbols except appendices, for which it is `UCAAlpha`. This produces the appendices numbered in upper-case letters (A, B, C, etc.) that were mentioned earlier.

`@SectionHeadingFont` is the font used for section headings. The default value shown above produces the bold face from the family of the initial font. A family name and size is acceptable here as well:

```
@SectionHeadingFont { Helvetica Base +2p }
```

produces section headings in the Helvetica font, two points larger than the initial font size.

`@SectionGap` determines how much space is left blank before each section title; the default value shown above is twice the current inter-line spacing. The special value `2b` may be used to get a page break rather than a space. `@SectionInContents` determines whether or not an entry is made in the table of contents for each section; it may be `Yes` or `No`. `@SectionContentsIndent` determines how far the contents entry is indented from the left margin if printed at all. There are similar options for other large-scale structure symbols.

3.3. Books

To produce a book, start off with the book setup file and the @Book symbol:

```
@SysInclude { book }
@Book
  @Title {}
  @Author {}
  @Edition {}
  @Publisher {}
  @BeforeTitlePage {}
  @OnTitlePage {}
  @AfterTitlePage {}
  @AtEnd {}
  @InitialFont { Times Base 12p }
  @InitialBreak { adjust 1.2fx hyphen }
  @InitialSpace { lout }
  @InitialLanguage { English }
  @PageOrientation { Portrait }
  @PageHeaders { Titles }
  @ColumnNumber { 1 }
  @FirstPageNumber { 1 }
  @IntroFirstPageNumber { 1 }
  @OptimizePages { No }
  @GlossaryText { @Null }
  @IndexText { @Null }
  @IndexAText { @Null }
  @IndexBText { @Null }
//
```

This shows all the options of @Book with their default values. As usual, these options may be given in any order, and only those to be changed need be given at all. The meaning of the // symbol after the last option is beyond our scope, but total disaster will ensue if it is forgotten.

The @Title, @Author, and @Edition options will appear on the title page, in the clines paragraph breaking style which centres each line (Section 1.9). The @Publisher option will appear at the foot of the title page.

The @BeforeTitlePage option will come out on the page (or pages) preceding the title page. This is where publishers advertise other books of a similar kind, perhaps from a series.

If @OnTitlePage is given it will replace the title page that usually appears, superseding the @Title, @Author, @Edition, and @Publisher options in the process.

The @AfterTitlePage option will come out on the page (or pages) following the title page. This is where publishers traditionally put copyright notices, information about production, and cataloguing-in-publication data. If this option is empty or omitted, there will be no such pages.

The @AtEnd option will come out on a single unnumbered page with no page headers or footers, and using the same margins as for even pages, after the very last page of the book; even after the index if there is one. It is intended to make it possible to include a back cover, so @PageOf last.page (Section 2.8) does not take account of any @AtEnd page. (To make a colophon, which occupies any number of numbered pages after the index, consult the

@Colophon symbol below.)

The remaining options are a selection of setup file options (Section 4.1) that frequently need to be changed. If your changes to the overall formatting are confined to these options, you can change them here and avoid having your own setup file. If you already have your own setup file, change them in either place and omit them in the other.

@InitialFont is the font of the bulk of the book, and should contain a family, a face, and a size. The default value selects the Times family, the Base face, and the 12 point size.

@InitialBreak controls the behaviour of paragraph breaking in the bulk of the book. It should have three parts: a paragraph breaking style (`adjust`, `ragged`, etc.), an inter-line spacing (1.2fx for single spacing, 2.4fx for double spacing, and so on), and either `hyphen` or `nohyphen` for turning hyphenation on or off. It may also have `nobreakfirst` or `nobreaklast` (or both), meaning to disallow a page break after the first line of a paragraph, or before the last, respectively.

@InitialSpace determines how Lout treats white space between two objects, as described in Section 1.19. @InitialLanguage determines the language of the bulk of the book.

@PageOrientation determines the orientation of the page. Its value may be `Portrait` (the default), `Landscape`, `ReversePortrait`, or `ReverseLandscape`. See Section 4.2 for further details.

@PageHeaders determines the appearance of page headers and footers. Its value may be `None`, `Simple`, `Titles`, or `NoTitles`. Section 4.4 has the details, but just briefly, `None` and `Simple` are not really suitable for books, `Titles` produces full running titles as in the present document, and `NoTitles` is like `Titles` with the running titles omitted, leaving just the page numbers.

@ColumnNumber is the number of columns per page in the bulk of the book, and may be anything from 1 (the default value) to 10. Irrespective of its value, all prefatory material, all chapter and appendix headings, and all figures and tables will be printed full width. There is a separate @IndexColumnNumber option in the setup file which determines the number of columns in the index (Section 2.11).

@FirstPageNumber is the page number to be given to the first non-introductory page. @IntroFirstPageNumber is the page number of the first introductory page; it will usually appear in Roman but must be given in Arabic.

Lout ordinarily places lines onto a page until space runs out, then moves to the next page and so on. This often produces ugly empty spaces at the bottoms of pages preceding large unbreakable displays. Setting the @OptimizePages option to `Yes` causes Lout to examine the overall situation and try to minimize the ugliness, using the T_EX optimal paragraph breaking algorithm. It takes two runs to do this, with intermediate results stored in Lout's cross reference database (Section 2.8); so deleting file `lout.li` will reset it, which might be wise after major changes. It is possible for the optimizer to cycle, never settling on a single final best version; this is usually caused by footnotes or floating figures inserted at points which end up near page boundaries.

The @GlossaryText, @IndexText, @IndexAText, and @IndexBText symbols allow you to insert some arbitrary text after the title of the glossary, index, etc., and before the entries.

After the compulsory `//` comes an optional preface:

```

@Preface
  @Title { About this book }
@Begin
@PP
...
@End @Preface

```

Since the title of most prefaces is simply Preface, that is the default value in English of the @Title option. Within the preface, just before @End @Preface, there may optionally be a sequence of sub-prefaces enclosed in @BeginSubPrefaces and @EndSubPrefaces, like this:

```

@BeginSubPrefaces
@SubPreface ... @End @SubPreface
@SubPreface ... @End @SubPreface
@EndSubPrefaces

```

After the preface there will automatically appear a table of contents listing the introduction, chapters, sections, subsections, appendices, sub-appendices, bibliography, and index as appropriate.

The pages up to this point will be numbered in lower case Roman numerals; subsequent pages will be numbered in Arabic starting from the @FirstPageNumber option of @Book. There is a setup file option for changing this to a single numbering sequence (see below).

Next comes an optional abbreviations sections, exactly like the preface except that its name is @Abbreviations and the default title in English is Abbreviation. There are no sub-abbreviations, and no support for what goes inside; you need to use a list or table to lay out the abbreviations, in the usual way.

Next comes an optional introduction, exactly like the preface except that its name is @Introduction and the default title in English is Introduction:

```

@Introduction
@Begin
@PP
...
@End @Introduction

```

It may have sub-introductions, exactly like sub-prefaces:

```

@BeginSubIntroductions
@SubIntroduction ... @End @SubIntroduction
@SubIntroduction ... @End @SubIntroduction
@EndSubIntroductions

```

After the introduction comes a sequence of chapters in the usual style:

```

@Chapter
  @Title { Australian Native Plants }
@Begin
@PP
...
@End @Chapter

```

No `@BeginChapters` or `@EndChapters` symbols are needed, because these chapters are not inside any other large-scale structure symbol.

In addition to all the usual options for large-scale structure symbols, `@Chapter` offers `@BypassWord`, which may be used to replace the ‘Chapter’ word for this chapter only. For example,

```

@Chapter
  @BypassWord { Appendix }
...

```

could be used to place (what appears to the reader to be) an Appendix at the end of a part, or indeed anywhere at all. The chapter numbers are not affected. To change this word in all chapters, the `@ChapterWord` setup file option is preferred.

Within a chapter, there may be a sequence of sections, each introduced by `@Section`, all bracketed by `@BeginSections` and `@EndSections`:

```

preceding text
@BeginSections
@Section ... @End @Section
@Section ... @End @Section
...
@Section ... @End @Section
@EndSections

```

Within each section there may be subsections, each introduced by `@SubSection`, and the sequence as a whole bracketed by `@BeginSubSections` and `@EndSubSections`:

```

preceding text
@BeginSubSections
@SubSection ... @End @SubSection
@SubSection ... @End @SubSection
...
@SubSection ... @End @SubSection
@EndSubSections

```

The subsections may contain sub-subsections, but there are no sub-sub-subsections.

After the chapters comes an optional sequence of appendices. Each is introduced by `@Appendix` in the usual way:

```

@Appendix
  @Title { Climatic Regions of Australia }
@Begin
@PP
...
@End @Appendix

```

No `@BeginAppendices` or `@EndAppendices` symbols are needed, because (like chapters) these appendices do not lie inside any other large-scale structure symbol. The appendices are numbered A, B, C, etc., as is conventional for them. Within each appendix there may be a sequence of subappendices, obtained with the `@SubAppendix` symbol and bracketed by `@BeginSubAppendices` and `@EndSubAppendices`:

```

preceding text
@BeginSubAppendices
@SubAppendix ... @End @SubAppendix
@SubAppendix ... @End @SubAppendix
...
@SubAppendix ... @End @SubAppendix
@EndSubAppendices

```

There are sub-subappendices following the same pattern, but no sub-sub-subappendices.

Apart from any colophon, described below, the book ends with the last chapter or appendix; any reference list or index will be appended automatically. Although we have described how to create books as though everything was in one large file, in practice it is much better to divide the book into multiple files, following the method given in Section 3.8.

In addition to the `@Title` option, each large-scale structure symbol (i.e. `@Preface`, `@Introduction`, `@Chapter`, `@Section`, `@SubSection`, `@SubSubSection`, `@Appendix`, `@SubAppendix`, and `@SubSubAppendix`) has a `@Tag` option for cross referencing (Section 2.8), an `@InitialLanguage` option for changing the language of that part of the document, and a `@RunningTitle` option which will be used in place of `@Title` in running headers if given. This last is useful when the full title is rather long.

The `@Chapter` symbol has three additional options for dividing the book into parts:

```

@Chapter
  @PartNumber { Part A }
  @PartTitle { The Ancient World }
  @PartText { ... }

```

Any chapter with a non-empty `@PartNumber` or `@PartTitle` option will become the first chapter of a part. It will be preceded by two pages containing the part number, title, and text, and there will also be an entry made in the table of contents. Parts are *not* numbered automatically: you have to supply your own numbers or letters as shown above.

After the last chapter or appendix, an optional colophon may be given:

```
@Colophon @Begin
```

```
This document was typeset using the Lout document  
formatting system. The resulting PostScript file  
was converted to PDF using GNU @! { ps2pdf }.
```

```
@End @Colophon
```

For this to work, however, the `@MakeColophon` option of the setup file must be changed to `Yes` (see next paragraph). A colophon appears at the very end of the book, after the index. It may occupy several pages, and these will be numbered as usual. See also the `@AtEnd` option above, which is intended to hold a one-page unnumbered back cover. As the example suggests, colophons these days are generally used for notes concerning how a book was produced. They are an old form that has been revived; previously, according to my dictionary, they contained information now printed on the title page.

A colophon is like a preface except that it appears at the end, and should logically be implemented like the `@Preface` symbol. Unfortunately, owing to problems behind the scenes it has instead been implemented like glossaries and indexes: you have to set a `@MakeColophon` option in the setup file to `Yes`. There are setup file options for setting the font and break style, column number and column gap, and heading (`@ColophonFont`, `@ColophonBreak`, `@ColophonColumnNumber`, `@ColophonColumnGap`, and `@ColophonWord`). There are also `@ColophonInContents` and `@ColophonPrefix` options for determining whether the colophon appears in the table of contents, and its prefix when structured page numbers are used.

The features described in other chapters are all available within books. A table of contents and index will appear automatically, and you will need to change the setup file to avoid them. Endnotes will appear at the end of the enclosing preface, introduction, chapter, or appendix. The numbering of figures and tables includes a chapter or appendix number: the first figure of Appendix C will be Figure C.1, and so on. Figures and tables within the preface or introduction are numbered 1, 2, 3, etc. A figure or table will never appear on the same page as the beginning of a chapter or appendix. References work as described in Chapter 5. As explained there, it is possible to have a list of references at the end of each chapter as well as at the end of the book.

Within the book setup file there is a `@BookSetup` symbol whose options control the appearance of features specific to books (in other words, the features described in this section):

```

@Use { @BookSetup
  # @TitlePageFont { Helvetica Base }
  # @SeparateIntroNumbering { Yes }
  # @PrefaceAfterContents { No }
  # @ReferencesBeforeAppendices { No }
  # @ChapterStartPages { Any }
  # @ChapterWord { chapter }
  # @ChapterNumbers { Arabic }
  # @ChapterHeadingFont { Bold 2.00f }
  # @ChapterHeadingBreak { ragged 1.2fx nohyphen }
  # @ChapterHeadingFormat { number @DotSep title }
  # @AboveChapterGap { 3.00f }
  # @ChapterInContents { Yes }
  # @ChapterContentsIndent { 0f }
}

```

This is just a representative sample of these options. Section 4.1 explains how to make your own setup file and change its options; here we just explain what the options do.

`@TitlePageFont` is the font used on the title page of the book, not including a size.

`@ChapterStartPages` determines what kinds of pages chapters and other major components of the book may begin on, and may be `Any`, `Odd`, or `Even`, meaning any page, odd-numbered pages only, or even-numbered pages only. It may also be `SamePage`, which means that chapters and appendices will continue directly after the previous chapter or appendix, on the same page (other major components such as the table of contents and index will start on a fresh page as usual). If you switch to `SamePage`, you will probably need to adjust `@ChapterHeadingFont` and `@AboveChapterGap`, described below, since their default values are intended for use with chapters and appendices that start on a fresh page; and you will also need to begin the body of your chapter with a paragraph symbol such as `@LP` or `@PP`, since otherwise there will be no vertical space between the chapter heading and body.

`@SeparateIntroNumbering` determines whether the introductory part of the book is to have a separate numbering sequence or not. `@ReferencesBeforeAppendices` determines whether any final list of references appears before or after any appendices. `@ChapterWord` determines the word used in chapter titles; its default value, `chapter`, produces ‘Chapter’ in the current language. The other six options control the appearance of chapters, and there are similar options for controlling the other large-scale structure symbols.

`@ChapterNumbers` determines how chapters will be numbered, and may be `None`, `Arabic`, `Roman`, `UCRoman`, `Alpha`, or `UCAAlpha`. The default value is `Arabic` for chapters and also for all large-scale structure symbols except appendices, for which it is `UCAAlpha`. This produces the appendices numbered in upper-case letters (A, B, C, etc.) that were mentioned earlier.

`@ChapterHeadingFont` is the font used for chapter headings. The default value shown above produces the bold face of the initial font family, at twice the initial size. A family name is acceptable here as well. `@ChapterHeadingBreak` is the break style for chapter headings.

`@ChapterHeadingFormat` allows you to change the format of the heading. The symbol `number` within it will be replaced by the number of the chapter (actually including the word `Chapter` as well in the current language, e.g. `Chapter 12`); the symbol `title` within it will be

replaced by the title. So you could write, say,

```
@ChapterHeadingFormat { @Box paint { lightgrey } { number @DP title } }
```

to get the title below the number, both enclosed in a box. The default value uses the `@DotSep` symbol from Section 4.4 to show the number and title separated by a dot and two spaces, like

```
@ChapterHeadingFormat { number. title }
```

except when there is no number. This option is applied to other major headings, in the preface, introduction, table of contents, appendices, reference list, and index. In all these other cases, `number` is an empty object, except for appendices, when it contains Appendix A or whatever.

There is a `@PartHeadingFormat` option for determining the format of part headings. It works in the same way as `@ChapterHeadingFormat`, with `number` and `title` symbols standing for the relevant `@PartNumber` and `@PartTitle` options. The default value is

```
@PartHeadingFormat { @CD number @DP @CD title }
```

which centres the number and title. The default paragraph breaking style is `clines`, but you may place a `@Break` symbol within `@PartHeadingFormat` to change this.

The example of boxed titles for chapters given above suffers from two practical deficiencies. First, the box won't extend right across the page, and second, when there is no number we don't want `@DP` either. Here is a value for `@ChapterHeadingFormat` that solves both problems:

```
@ChapterHeadingFormat {
  number @Case {
    {} @Yield @Box paint { lightgrey } @HEExpand { title }
    else @Yield @Box paint { lightgrey } @HEExpand { number @DP title }
  }
}
```

The `@Case` symbol (Expert's Guide [5]) distinguishes between the cases where `number` is empty and non-empty; the `@HEExpand` symbol expands the horizontal space occupied by the heading to the maximum possible, so that when the box is drawn around it it will occupy the full page width. The format can be as complicated as you like, and there is no need to squeeze it all onto one line; as always, the end of a line is the same as one space.

Every chapter and appendix begins on a new page. `@AboveChapterGap` determines how much space is left blank above the chapter title; the default value is three times the initial font size. There are similar options for other large-scale structure symbols, which determine how much space is left before each one.

`@ChapterInContents` determines whether or not an entry is made in the table of contents for each chapter; it may be `Yes` or `No`, but would always be `Yes`. The default value of the corresponding options for sub-subsections and sub-subappendices, however, is `No`. `@ChapterContentsIndent` determines how far from the left margin the contents entry is indented if it is printed at all. The default value shown above causes no indenting; but the default values for the corresponding `@SectionrContentsIndent` and `@SubSectionrContentsIndent` symbols are `3f` and `6f` respectively, producing the familiar indenting structure.

3.4. Overhead transparencies

To produce overhead transparencies¹ (hereafter called overheads), start off with the slides setup file and the `@OverheadTransparencies` symbol:

```
@SysInclude { slides }
@OverheadTransparencies
  @Title {}
  @RunningTitle {}
  @Author {}
  @Institution {}
  @DateLine { No }
  @InitialFont { Times Base 20p }
  @InitialBreak { ragged 1.2fx nohyphen }
  @InitialSpace { lout }
  @InitialLanguage { English }
  @PageOrientation { Portrait }
  @PageHeaders { Titles }
  @FirstPageNumber { 1 }
  @FirstOverheadNumber { 1 }
  @FirstLectureNumber { 1 }
  @OptimizePages { No }
//
```

This shows all the options of `@OverheadTransparencies` with their default values. As usual with options, they may be given in any order, and only the ones whose values need to be changed need be given at all. The meaning of the `//` symbol after the last option is beyond our scope, but disaster will ensue if it is forgotten.

If `@Title` is not empty, an initial overhead will be produced containing the `@Title`, `@Author`, `@Institution`, and `@DateLine` options. `@DateLine` may be set to `No`, meaning no dateline, `Yes`, meaning print the current date, or anything else, which is taken to be a date and printed.

Each overhead has a running header printed in small type at the top left. The `@RunningTitle` option goes into this header, or, if there is no `@RunningTitle` option, `@Title` is used instead.

The remaining options are a selection of setup file options (Section 4.1) that frequently need to be changed. If your changes to the overall formatting are confined to these options, you can change them here and avoid having your own setup file. If you already have your own setup file, change them in either place and omit them in the other.

`@InitialFont` is the font in which the overheads will be set, and should contain a family, a face, and a size. A good font size for overheads is 20 points, so that is the default size.

`@InitialBreak` controls the behaviour of paragraph breaking in the overheads. It should have three parts: a paragraph breaking style (`adjust`, `ragged`, etc.), an inter-line spacing (1.2fx for single spacing, 2.4fx for double spacing, and so on), and either `hyphen` or `nohyphen` for turning

¹In Version 3.15 overhead transparencies were updated and brought into line with the other document types. Although existing source files do not need to be modified, their printed appearance may change (spacing, running headers). There are some new setup file options, and some changes to existing setup file options.

hyphenation on or off. Adjusted lines and hyphenated words are difficult to read from overheads, so the default is not to have them. `@InitialSpace` determines how Lout treats white space between objects (Section 1.19). `@InitialLanguage` determines the language of the overheads.

`@PageOrientation` determines the orientation of the page. Its value may be `Portrait` (the default), `Landscape`, `ReversePortrait`, or `ReverseLandscape`. See Section 4.2 for further details.

`@PageHeaders` determines the appearance of page headers and footers. Its value may be `None`, `Simple`, `Titles`, or `NoTitles`. Section 4.4 has the details, but just briefly, `None` produces no page headers, `Simple` produces page numbers only, `Titles` produces full running titles, and `NoTitles` is similar to `Simple` in this context.

`@FirstPageNumber` is the number given to the first page, `@FirstOverheadNumber` is the number given to the first overhead, and `@FirstLectureNumber` is the number given to the first lecture, of which more below. See preceding sections for `@OptimizePages`.

After the compulsory `//` come the overheads themselves. There are two alternatives: a series of overheads, corresponding to a single lecture, or a series of series of overheads, corresponding to a series of lectures. If the first is wanted, use this arrangement:

```
@SysInclude { slides }
@OverheadTransparencies
  @Title { ... }
  @Author { ... }
  @DateLine { ... }
  ...
//
@Overhead ... @End @Overhead
@Overhead ... @End @Overhead
...
@Overhead ... @End @Overhead
```

`@Overhead` is a large-scale structure symbol, similar to `@Section`, with the usual options:

```
@Overhead
  @Title { Trends in investment since 1980 }
  @RunningTitle { Investment }
  @Tag { investment }
  @InitialLanguage { English }
@Begin
...
@End @Overhead
```

If `@Title` is given it will appear as a centred, bold display at the beginning of the overhead. As usual, these options may be given in any order or omitted altogether.

The body of the overhead is quite arbitrary. Typically one tends to use lists and displays more than paragraphs, but all the usual features are available. Each overhead begins on a fresh page, but it may occupy more than one page.

`@Overhead` also has a `@Format` option which allows you to specify an arbitrary format for the body of the overhead (that is, everything except its title). For example,

```
@Format { @CurveBox @HEExpand @VExpand @Body }
```

encloses the body in a curvebox, with the box expanded to the full available width and height. Unlike the similar option for figures and tables, however, this `@Format` option unfortunately has not been set up to work with multi-page overheads, so if you use the format just given you have to make sure your overheads all fit on one page. To draw boxes around the *entire* page, use the `@PageBox` setup file options.

Lout does not provide any special support for overlays. A good way to make them is to first produce one overhead containing all the layers simultaneously. Once this is correct, enclose the entire body of the overhead in white `@Colour`, make one copy of the text of the overhead for each layer, separating the copies with `@NP` (new page) symbols, and, in each copy, enclose the parts that are to appear in that layer in black `@Colour` (or any other colour). This works because white `@Colour` makes an object invisible without altering its size.

We turn now to the second major alternative, which is a series of lectures, like this:

```
@SysInclude { slides }
@OverheadTransparencies
  @Title { ... }
  @Author { ... }
  @DateLine { ... }
  ...
//
@Lecture ... @End @Lecture
@Lecture ... @End @Lecture
...
@Lecture ... @End @Lecture
```

`@Lecture` is a large-scale structure symbol, again with the usual options:

```
@Lecture
  @Title { Macro-Economic Policies for the Nineties }
  @RunningTitle { Macro-economic policies }
  @Tag { macro-economics }
  @InitialLanguage { English }
@Begin
...
@End @Lecture
```

If `@Title` is non-empty the series of overheads will begin with an overhead containing the title alone, centred on the page using the `clines` paragraph breaking style. This means that it makes sense to have a multi-line title. Any text following the `@Begin` will appear under the lecture title as you would expect. Within the body of `@Lecture`, place a series of overheads bracketed by `@BeginOverheads` and `@EndOverheads`:

```
@BeginOverheads
@Overhead ... @End @Overhead
...
@EndOverheads
```

The @Overhead symbol is exactly as described earlier.

The features described in other chapters are available with overheads. Endnotes and references appear automatically at the end of the overheads. You can have a table of contents, by setting the @MakeContents option of the setup file to Yes. It will appear automatically after any title overhead. The setup file options have been set on the assumption that you want your lectures to appear in the table of contents, but not individual overheads. It is not possible to have an index, and it is not possible to have multiple columns.

Within the slides setup file there is an @OverheadSetup symbol whose options control the appearance of features specific to overheads (in other words, the features described in this section). Here are some of these options and their default values:

```
@Use { @OverheadSetup
# @DateLine { No }
# @FirstOverheadNumber { 1 }
# @FirstLectureNumber { 1 }
# @ContentsWord { contents }
# @LectureNumbers { Arabic }
# @OverheadNumbers { Arabic }
# @TitlePageFont { Helvetica Base }
# @TitleFormat { @Center clines @Break title }
# @AuthorFormat { @Center clines @Break author }
# @InstitutionFormat { @Center clines @Break @I institution }
# @DateLineFormat { @Center date }
# @AboveTitleGap { 0.5i }
# @AboveAuthorGap { 1.0i }
# @AboveInstitutionGap { 0.5i }
# @AboveDateLineGap { 0.5i }
# @LectureHeadingFont { Bold 1.20f }
# @LectureHeadingFormat { @Centre number @DP @Centre title @DP }
# @OverheadHeadingFormat { @Centre title @DP }
# @OverheadHeadingFont { Bold }
# @LectureInContents { Yes }
# @OverheadInContents { No }
# @ReferencesInContents { Yes }
}
```

For an introduction to setup files and their options, consult Section 4.1. The first four options are as for @OverheadTransparencies as described above. @ContentsWord determines the table of contents heading; its default value, contents, produces ‘Contents’ in the current language. @LectureNumbers and @OverheadNumbers determine the style of numbering of lectures and overheads, and may be None, Arabic, Roman, UCRoman, Alpha, or UCAAlpha as usual. Next come options for setting the font of the overall title page, the format of the title, author, institution, and dateline parts of it, the gap above the title, author, institution, and dateline that appear on that page; then options controlling the appearance of the headings at the start of each lecture and overhead, and finally options which determine which entries are made in any table of contents.

The @LectureHeadingFormat option determines the format of the heading of each lecture.

Within it, the symbol number stands for the number of the lecture, including the ‘Lecture’ word if there is one, and title stands for the title of the lecture. The default value centres the number and title, with display gaps below each one. @OverheadHeadingFormat is similar; it has the same symbols but the default value chooses not to use number.

Other setup file options exist which permit you to have a box drawn around each overhead, and to change the page size, margins, and orientation. These are described in Chapter 4.

Section 4.4 describes the setup file options that control the appearance of page headers and footers. With overheads, the values given to the @MajorTitle, @MinorTitle, @MajorNum, and @MinorNum symbols within those options are as follows. If @Lecture is being used:

@MajorTitle	The @RunningTitle option of @OverheadTransparencies, or its @Title option if @RunningTitle is absent;
@MinorTitle	The @RunningTitle option of the current @Lecture, or else its @Title option if @RunningTitle is absent;
@MajorNum	The number of the current @Lecture;
@MinorNum	A two-part number, for example 5.2, containing the number of the current @Lecture and the number within that lecture of the current overhead.

If @Lecture is not being used:

@MajorTitle	The @RunningTitle option of @OverheadTransparencies, or its @Title option if @RunningTitle is absent;
@MinorTitle	Empty;
@MajorNum	Empty;
@MinorNum	The number of the current overhead.

The first page occupied by any overhead is a Start page; subsequent pages are NonStart pages. There are no Intro pages.

3.5. Stand-alone illustrations

This section describes how to use Lout to produce an illustration for inclusion in some other document, which may itself be a Lout document but need not be. The opposite process, the inclusion of an illustration in a Lout document, is the subject of Section 8.9.

Suppose you want to produce the following logo for inclusion in some other document:



This is just an object, and it is not hard to make it using Lout’s graphics features:

```
45d @Rotate @CurveBox { ARMY @LP 180d @Rotate ARMY }
```

The problem is that objects ordinarily come out on pages with margins, page numbers, and so

forth, which we don't want here. The solution is to use the illustration document type, whose setup file, curiously enough, is called picture:

```
@SysInclude { picture }
@Illustration {
  45d @Rotate @CurveBox { ARMY @LP 180d @Rotate ARMY }
}
```

After the usual @SysInclude line comes one @Illustration symbol. Following it is an arbitrary object which becomes the entire result, with no pages and no margins, ready for inclusion in some other document as an illustration.

The @Illustration symbol has options for setting the initial font, paragraph breaking style, colour, and language. Here they are with their default values:

```
@Illustration
@InitialFont { Times Base 12p }
@InitialBreak { adjust 1.2fx hyphen }
@InitialSpace { lout }
@InitialLanguage { English }
@InitialColour { black }
@InitialBackgroundColour { white }
{
  ...
}
```

You can specify any colour from the list in Section 8.1, for example blue, and then your illustration will have that colour wherever it is included.

Because there are no pages, the width and height of the result are indeterminate, depending on how large the object turns out to be. This makes things very awkward for filled paragraphs and centring, which depend on knowing how much space is available to be occupied. So you should either avoid filled paragraphs and all displays and lists altogether in illustrations, or else enclose your object in a @Wide symbol:

```
@Illustration 5c @Wide {
  ...
}
```

to make clear how wide you want your illustration to be.

The technical name for a file containing a stand-alone illustration is 'encapsulated PostScript file' or 'EPS file' for short. To get Lout to produce an encapsulated PostScript file instead of an ordinary PostScript file, you have to use the -EPS Unix command line flag. For example, suppose the Lout file containing our example illustration is called army; then the appropriate Unix command for formatting it is

```
lout -EPS army > army.eps
```

An EPS file is supposed to contain only one 'page', so Lout will refuse to generate any second or subsequent pages when the -EPS flag is given. There is also a minor difference in format

between ordinary and encapsulated PostScript files, which is why the `-EPS` flag is needed at all.

3.6. Plain text documents

Occasionally you may need to produce an output file containing plain text rather than PostScript, for example for an online manual entry or to send as electronic mail. Any document that can be produced by Lout in PostScript can be produced in plain text as well, by adding a `-p` flag to the Unix command line:

```
lout -p simple
```

No other changes are required. Here we are sending the output directly to the screen, but it can be redirected to a file, or piped through the `more` command for viewing one page at a time, etc.

Of course, plain text is an extremely limited medium of communication compared with PostScript, and this forces Lout to make some rather drastic compromises:

- Symbols like `@Bullet`, which stand for unusual characters, produce printable characters which approximate the PostScript ones. For example, `@Bullet` produces `o`. However, the `@Char` and `@Sym` symbols often produce unprintable characters, and are best avoided;
- All font and size changes are ignored, since plain text has only one font and size. Every character is taken to be $\frac{1}{10}$ inch wide and $\frac{1}{6}$ inch high;
- No underlines are printed;
- No margin notes are printed;
- Scaled objects are not printed unless the scale factor happens to be 1;
- Rotated objects are not printed unless the angle happens to be zero degrees. This means that page orientations (Section 4.2) other than Portrait do not work;
- Ruled lines are not printed, and paint and colour options are ignored. This spoils the graphics and graphs of Chapters 8, 9, and 10.

Despite the problems, many things work surprisingly well. Tables, for example, look very good. It does no harm to try things and see if they work out.

The worst problem with plain text is that characters cannot be placed at arbitrary points on the page. A superscript, for example, is impossible to place correctly, so Lout uses a different layout for footnote labels (and makes a mess of equations, which are best avoided). Because of this problem it's best to make all horizontal lengths multiples of $\frac{1}{10}$ inch (conveniently expressed as `1s`), and all vertical lengths multiples of $\frac{1}{6}$ inch (conveniently expressed as `1f`). To help you do this, the setup files contain many entries that look like this example:

```
# @InitialBreak { {adjust 1.2fx hyphen} @OrIfPlain {ragged 1fx nohyphen} }
```

The meaning is that the value of `@InitialBreak` will be `adjust 1.2fx hyphen` usually, but will switch to `ragged 1fx nohyphen`, which is better suited to plain text, if the `-p` command line flag is used. These setup file values allow you to switch from PostScript to plain text and back again

without changing anything at all except the `-p` command line flag.

If you use `lout -P` instead of `lout -p`, the plain text output will contain a form-feed character (control-L) after each page except the last. This character causes most printing devices to start a new page, which is very useful when your page height is not exactly right.

The `@Document` symbol (Section 3.1) has an `@Unpaginated` option which, when set to `Yes`, causes the plain text output to appear unpaginated, that is, in one long continuous stream with no page breaks. Its value is ignored if plain text output is not in effect, so it can be safely set to `Yes` in documents intended for formatting both ways. The usual margins apply; footnotes appear at the end; floating figures and tables do not work. Lout stupidly reads the entire document before producing any output when this option is used, so if the document is long you might run out of memory.

3.7. PDF (Adobe Portable Document Format) documents

You can get Lout to produce PDF (Adobe Portable Document Format) output as an alternative to PostScript, by adding `-PDF` to the command line like this:

```
lout -PDF simple > simple.pdf
```

No other changes are required.

When viewed with a PDF viewer, entries in tables of contents and indexes can be clicked on and this transports the viewer to the part of the document referenced by the link, as described in Section 2.8. Recent versions of PostScript support this feature too, via the *pdfmark* feature, and Lout's PostScript contains links expressed in this way. Unfortunately, few PostScript viewers know how to handle these links; those that don't just ignore them.

Regrettably, the PDF output produced by Lout is inferior at graphics: the advanced features of the `@Diag` and `@Graph` packages do not produce any output. One can still format documents that contain them, but the results are disappointing. The only way to get the best of everything is to produce PostScript, and then either pass it through a 'distillation' program to produce PDF, or else view it with a PostScript viewer that understands links.

When generating PostScript for subsequent distillation to PDF, the `@DocInfo` symbol may be useful. Placed anywhere in the document, it generates PostScript which causes the subsequent PDF to contain a 'document info dictionary' containing the author of the document, its title, and some keywords:

```
@DocInfo
  author { Jeffrey H. Kingston }
  title { A User's Guide to the Lout Document Formatting System }
  keywords { Lout, PostScript, PDF }
```

The values of the options are restricted to sequences of simple words, as shown, since this is all that PDF document info dictionaries may contain. All three options are optional; if one is omitted, the dictionary will simply not have the corresponding entry, which is legal in PDF. There is no way to have the author and title taken automatically from `@Author` and `@Title` options.

3.8. Organizing large documents

It is not a good plan to store a large document in a single large file. It takes too long to find things in it, and if some catastrophe occurs, you lose the lot. Lout encourages you to break documents into pieces by its willingness to read a sequence of files (lout file1 file2 ...). For large documents, the following plan is recommended.

Suppose you are making a book whose third chapter contains sections on banksias, grevilleas, acacias, and eucalypts. Place each section, from @Section to @End @Section, in a separate file, making four files called, say, banksias, grevilleas, acacias, and eucalypts. Then make a single file for the chapter as a whole whose contents are as follows:

```
@Chapter
  @Title { Australian Native Plants }
  @Tag { natives }
@Begin
Australian native plants provide a distinctive identity to the garden. Although
less colourful than their European alternatives, some banksias and grevilleas do
flower strongly, and of course the acacias (wattles) are unsurpassable in late winter.
@BeginSections
@Include { banksias }
@Include { grevilleas }
@Include { acacias }
@Include { eucalypts }
@EndSections
@End @Chapter
```

The @Include symbol causes Lout to read the file whose name follows it between braces, just as though the contents of that file had been included at that point.

With this arrangement you can easily rearrange the order of the sections: just swap their @Include lines. You should be using Lout's automatic cross referencing features (Section 2.8), so you don't have to worry about keeping cross references up to date. You can also temporarily delete a section by placing a # character at the start of its line:

```
# @Include { acacias }
```

This works because # is the *comment character*: Lout will ignore this character (unless enclosed in double quotes) and everything following it up to the end of the line. You can even temporarily delete every section except the one you are working on at the moment, using these comments.

Suppose now that this chapter file is called natives, and you have others called preface, flowers, etc. Then you can make one file (call it garden) for the whole book like this:

```

@SysInclude { book }
@Book
  @Title { The Australian Garden }
  @Author { Martha S. Vineyard }
//
@Include { preface }
@Include { flowers }
@Include { shrubs }
@Include { natives }
@Include { trees }

```

You can play the same tricks here: swap chapters around, or temporarily delete one or more with a #. When a chapter is finished you can temporarily delete it to save formatting time and paper, and bring it back at the end. To format the book, use `lout garden > out.ps` in Unix. Lout will read each `@Include` file as it comes to it, and if it finds an `@Include` of a section while reading a chapter file, it will read the section too.

If the order of your chapters is fairly stable, it might be advantageous to use the `@Bypass-Number` option of `@Chapter` (described in Appendix B) to fix the numbers of all your chapters, so that you get correct chapter numbers even when formatting one chapter at a time.

If you decide to store chapters in separate Unix directories, make sure that any `/` characters in the file names are enclosed in double quotes:

```
@Include { "natives.dir/acacias" }
```

Be careful not to give the directory the same name as your chapter file. You might also find it useful to construct your book *top-down*, as computer scientists call it, laying out all the chapters and sections as empty skeletons and filling their contents in later.

When some part of your document has to be repeated, one way to avoid entering it twice is to place that part in a separate file and use `@Include` in two places to include it twice. This works, but there are two caveats. First, it may be better to use a definition (Section 2.13), since that gives you an object with a name, which you can use with confidence anywhere at all. Second, Lout treats `@Include` in a peculiar way when it appears in the setup part of a document (in definitions, databases, and the `@Use` clauses that appear within setup files): it reads the file as usual the first time, and silently skips it the other times. This is done to simplify the handling of files of definitions that depend on other files of definitions, as described in the Expert's Guide [5].

Chapter 4. Changing the Overall Format

The symbols of Lout make many decisions behind the scenes. Even the humble @PP symbol has to decide how much vertical space to leave, and how far to indent the first line of the paragraph. How to change these decisions is the subject of this chapter.

4.1. Setup files

As mentioned briefly in Section 1.1, each Lout document begins with an instruction to include (i.e. to read) a *setup file*:

```
@SysInclude { doc }
```

The setup file's name in this example is `doc`, and the `Sys` in `@SysInclude` means that `doc` is stored in the *Lout system include directory*, which is where all the standard setup files are kept. Each document type (Chapter 3) has its own setup file, and each specialized package (for equations, tables, and so on) has a setup file too.

To change the overall format of a document, you need to create your own setup file by copying and modifying one of the standard ones. We will assume that you are making an ordinary document, with the `doc` setup file, but a similar procedure works for any setup file.

You first need to find out the name of the Lout system include directory, by typing

```
lout -V
```

in Unix. This causes Lout to print out various facts about itself. Then, supposing that this tells you that the Lout system include directory is `/usr/lout/include`, type the Unix command

```
cp /usr/lout/include/doc mydoc
```

to place a copy of the `doc` setup file in your directory, renaming it `mydoc`. Since `doc` is read-only, you may also need to change the mode of `mydoc` to be writable (by `chmod +w mydoc` in Unix). Now replace

```
@SysInclude { doc }
```

at the beginning of your document by

```
@Include { mydoc }
```

and Lout will read `mydoc` as the setup file instead of `doc`. Since the two files are at present identical, this has changed nothing so far; but now any changes you make to `mydoc` will affect your document. Notice the use of `@Include` rather than `@SysInclude`; `@Include` will search your current directory for `mydoc`, whereas `@SysInclude` searches only the system directory.

The remainder of this section is a tour through `doc`, explaining the various parts and how to

modify them. The first lines that actually do anything are these:

```
@SysInclude { langdefs }
@SysInclude { bsf }
@SysInclude { dsf }
@SysInclude { docf }
```

We already know that `@SysInclude` causes Lout to read a file from the Lout system include directory. File `langdefs` tells Lout what languages there are, and files `bsf` and `dsf` contain the definitions of the `BasicSetup` and `DocumentSetup` packages, in which all the symbols of the first two chapters of this guide are defined. File `docf` contains extra definitions specific to ordinary documents (as distinct from technical reports, books, or the other document types of Chapter 3). So this line will be different in the setup files for those other types.

The next line is

```
@Include { mydefs }
```

This searches your current directory for a file called `mydefs`, which (as Section 2.13 explains) is intended to hold your own personal set of definitions of new symbols. It does no harm if there is no `mydefs` file in your current directory, because `@Include` then searches the Lout system include directory for it, and there is an empty `mydefs` file there. When using your own setup file, you might prefer to delete `@Include { mydefs }` and put your definitions in its place, so that you have one file of setup material rather than two.

Next we come to the `BasicSetup @Use` clause. It looks like this:

```
@Use { @BasicSetup
# @InitialFont { Times Base 12p }
# @InitialBreak { {adjust 1.20fx hyphen} @OrlfPlain {ragged 1fx nohyphen} }
# @InitialSpace { lout }
# @InitialLanguage { English }
# @InitialColour { black }
# @InitialBackgroundColour { white }
# @OptimizePages { No }
# @HeadingFont { Bold }
# @ParaGap { 1.3vx @OrlfPlain 1f }
# @ParaIndent { 2.00f @OrlfPlain 5s }
}
```

`@BasicSetup` is a symbol, and `@InitialFont`, `@InitialBreak`, etc. are its options. There are more options than we've shown; the display above just shows the first few. You change the overall format of your document by changing these options.

A `#` causes Lout to ignore that character and the rest of the line (such ignored parts are called *comments* and `#` is the *comment character*). As it stands, then, the options are all hidden within comments, so their default values (shown within braces in the comments) are in force. To change an option, delete the `#` and change the value between braces. For example, to set the document in Helvetica 10 point font, change the `@InitialFont` line to

```
@InitialFont { Helvetica Base 10p }
```

We won't go through all the options now, since they are the subject of following sections.

The `@OrlfPlain` symbol that appears within some setup file options is used to set the value of the option differently when plain text output (Section 3.6) is being produced. For example, the default value of `@InitialBreak` is usually `adjust 1.20fx hyphen`, but when plain text is being produced it switches to `ragged 1fx nohyphen`. When changing such options you can leave the `@OrlfPlain` symbol there and change one or both of the alternative values as you wish.

Next comes a similar `@Use` clause, for the `DocumentSetup` package:

```
@Use { @DocumentSetup
# @PageType { A4 @OrlfPlain Other }
# @PageWidth { 80s }
# @PageHeight { 66f }
# @PageOrientation { Portrait }
# @PageBackground {}
# @TopMargin { 2.5c @OrlfPlain 6f }
}
```

This one has many options, starting with options for page layout as shown, then going on to figures and tables, tables of contents, etc.

The standard setup files are all much the same up to this point; the main variation is that in some files, some options are already set. The slides setup file, for example, contains

```
@InitialFont { Times Base 20p }
```

so that overhead transparencies will have a large font size. However, now comes a third `@Use` clause whose symbol and options depend on the document type. For ordinary documents (i.e. in the doc setup file) this clause is (once again we show just some of the options):

```
@Use { @OrdinarySetup
# @IndexWord { index }
# @AppendixWord { appendix }
# @SectionNumbers { Arabic }
# @AppendixNumbers { UCAAlpha }
# @SectionHeadingFont { Bold }
}
```

In the slides setup file for overhead transparencies, we find this:

```

@Use { @OverheadSetup
# @DateLine { No }
# @ContentsWord { contents }
# @FirstOverheadNumber { 1 }
# @OverheadNumbers { Arabic }
# @TitlePageFont { Helvetica Base 1.5f }
# @OverheadHeadingFont { Bold }
# @OverheadInContents { No }
}

```

In general this third @Use clause assigns values to options specific to the document type we are using, whereas the first and second @Use clauses assign values to options that are relevant to many or all document types.

The setup file ends with a comment identifying a spot where database declarations may be put, and two such declarations, one for fonts and the other for reference printing styles.

The setup files used with other packages, such as C and C++ program printing, diagrams, and graphs, are similar to the doc setup file we have just gone through. They contain a @SysInclude line analogous to @SysInclude { dsf } for reading the package's definition, followed by a @Use clause for setting the package's options. The same procedure is followed for changing these options. For example, to change the options of the diag package, copy file diag from the Lout system include directory to your directory, replace the

```
@SysInclude { diag }
```

line at the top of your document by @Include { mydiag }, then edit mydiag and change the options as you wish.

If you are using several packages and you would like a single setup file, that is quite easy to arrange. For example, suppose you have

```

@Include { mydoc }
@Include { mydiag }
@Include { mycprint }

```

To create a single setup file, just concatenate these three files into one file (call it mysetup, say), and replace the three lines by

```
@Include { mysetup }
```

As explained earlier, you can even replace the @Include { mydefs } line within the setup file by the actual definitions, giving just one file of setup material for the entire document.

4.2. Page size and page orientation

This section explains how to use the setup file options that determine page size and page orientation. Here they are with their default values:

```
@PageType { A4 }
@PageWidth { }
@PageHeight { }
@PageOrientation { Portrait }
```

The default value at your site may be different, since installers of Lout are recommended to set it to the usual size of a piece of paper at their location. The easy way to change the page size is to set the `@PageType` option to the name of the paper you use:

	<i>width in points</i>	<i>height in points</i>
@PageType { Letter }	612p	792p
@PageType { Tabloid }	792p	1224p
@PageType { Ledger }	1224p	792p
@PageType { Legal }	612p	1008p
@PageType { Statement }	396p	612p
@PageType { Executive }	540p	720p
@PageType { A0 }	2380p	3368p
@PageType { A1 }	1684p	2380p
@PageType { A2 }	1190p	1684p
@PageType { A3 }	842p	1190p
@PageType { A4 }	595p	842p
@PageType { A5 }	420p	595p
@PageType { B4 }	729p	1032p
@PageType { B5 }	516p	729p
@PageType { Folio }	612p	936p
@PageType { Quarto }	610p	780p
@PageType { 10x14 }	720p	1008p

This will automatically assign the widths and heights shown above to the `@PageWidth` and `@PageHeight` options, so you don't have to worry about those options. If your paper size is not on this list, set `@PageType` to `Other` and supply your own width and height:

```
@PageType { Other }
@PageWidth { 12.0c }
@PageHeight { 18.0c }
```

The width and height may each be any length (Section 1.2), and do not have to be in points.

The basic page orientations are *portrait* and *landscape*:

```
@PageOrientation { Portrait }
```



```
@PageOrientation { Landscape }
```



When changing to Landscape, do not change the page type, page width, or page height, and do not change the way you feed your paper into the printer. Lout knows what to do.

Two other orientations are provided which are 180° rotations of the basic ones:

@PageOrientation { ReversePortrait }



@PageOrientation { ReverseLandscape }

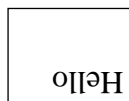

ReverseLandscape might be useful when post-processing the PostScript output to print two landscape pages per sheet. The @PageOrientation symbol is available at the start of a document, as well as in the setup file, like @InitialFont and @PageHeaders.

4.3. Page margins, page boxes, and page backgrounds

There are six options for setting the top and bottom margins on each page, and the left and right margins on odd and even pages. Here they are with their default values:

```
@TopMargin { 2.50c }
@FootMargin { 2.50c }
@OddLeftMargin { 2.50c }
@OddRightMargin { 2.50c }
@EvenLeftMargin { 2.50c }
@EvenRightMargin { 2.50c }
```

When setting these options you must ensure that

$$\text{@OddLeftMargin} + \text{@OddRightMargin} = \text{@EvenLeftMargin} + \text{@EvenRightMargin}$$

In other words, the total margin on odd pages must be the same as on even pages.

In addition, four options are provided which add extra left and right margins to the page *body* (that is, everything but the running headers and footers):

```
@OddLeftBodyMargin { 0c }
@OddRightBodyMargin { 0c }
@EvenLeftBodyMargin { 0c }
@EvenRightBodyMargin { 0c }
```

The default is to add no page body margins, as shown. Most people who use page body margins would change only @OddRightBodyMargin and @EvenLeftBodyMargin, since those are the outside margins. As for ordinary margins, the total (left plus right) page body margin must be the same on odd and even pages. Margin notes (Section 2.4) occupy body margin space.



You can have a box drawn around each page if you wish. Here are the relevant options and their default values:

```

@PageBoxType { None }
@PageBoxMargin { 1.00c }
@PageBoxLineWidth {}
@PageBoxPaint { None }
@PageBoxShadow { 0.06c }

```

You get boxes by changing the @PageBoxType option:

@PageBoxType { None }	(no box)
@PageBoxType { Box }	
@PageBoxType { CurveBox }	
@PageBoxType { ShadowBox }	

Page boxes reduce the amount of space available to the page contents, so your columns will become somewhat narrower and shorter when you introduce them.

The @PageBoxMargin, @PageBoxLineWidth, @PageBoxPaint, and @PageBoxShadow options affect the page box exactly as the margin, linewidth, paint, and shadow options described for other boxes in Section 8.3 do. For example,

```

@PageBoxType { CurveBox }
@PageBoxMargin { 1.0c }
@PageBoxPaint { grey }

```

draws a curved box, painted grey, around each page, with a one centimetre margin between its boundary and the page contents. If the left margin is 2.5 centimetres, say, this gives a total left margin from the page edge to the page contents of 3.5 centimetres.

More generally, you can enclose each page in any object at all, by means of the @PageEnclose option:

```
@PageEnclose { @Body }
```

Within this option, @Body stands for the page, and it must occur exactly once. You could place a curved box around each page, for example, by writing

```
@PageEnclose { @CurveBox @Body }
```

This is of course also available from the @PageBox symbols, but with @PageEnclose there are infinitely many other possibilities.

Finally, it is possible to have something other than the usual white background on the page, using the @PageBackground option:

```
@PageBackground { @Scale 60d @Rotate lightgrey @Colour DRAFT }
```

The value of the option is an object which is drawn on each page, within the margins, before the page contents are drawn. This example draws a large word DRAFT in light grey diagonally across each page:

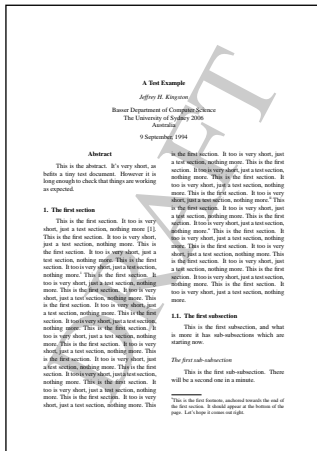

You have to find a suitable angle by experiment. As Section 8.6 explains, @Scale with no scale factor only takes account of the available horizontal space, not the available vertical space, so if your angle is too steep the result will be too tall for the page and you will get a regrettably obscure warning message about a ‘broken size constraint.’ The solution is to try a smaller angle.

Another useful page background draws marks to show where the margins lie:

```
@PageBackground { @BoundaryMarks }
```

produces something like this around each page:

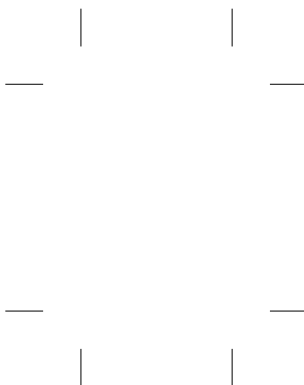

The @BoundaryMarks symbol has options for controlling the line width (thickness), the line length, and the gap between the ends of the lines and the corner of the text area:

```
@PageBackground {
  @BoundaryMarks
    linewidth { 0.2p }
    length { 0.5c }
    gap { 0.5c }
}
```

This shows the default values: 0.2 points for line width, 0.5 centimetres for the others.

4.4. Page numbers and running headers

A *page header* is a line at the top of a page containing a page number or running title. A *page footer* is a similar line at the bottom of a page. This section describes the setup file options that control the appearance of page headers and footers.

There are four basic styles, selected by the `@PageHeaders` option:

<code>@PageHeaders { None }</code>	No page headers, no page footers.
<code>@PageHeaders { Simple }</code>	No footers, and a centred page number between hyphens for header on every page whose number is not 0 or 1.
<code>@PageHeaders { Titles }</code>	Full running titles as in the present document.
<code>@PageHeaders { NoTitles }</code>	Page numbers placed as for Titles, but with the titles themselves blanked out.

Titles and NoTitles use Lout's cross-referencing machinery, so will require a few runs to settle down. None and Simple do not, so they work first time and may be used with the `-s` command line flag. Section 2.8 has a fuller discussion of these ramifications of cross referencing.

The next step is to set the page numbers, using the `@PageNumbers` and `@FirstPageNumber` options. There are two useful values for `@PageNumbers`:

<code>@PageNumbers { Arabic }</code>	Arabic page numbers
<code>@PageNumbers { Roman }</code>	Lower-case Roman page numbers

although the full range of choices is None, Arabic, Roman, UCRoman, Alpha, and UCAAlpha. `@FirstPageNumber` is the number of the first page. Its default value is of course 1, although

```
@FirstPageNumber { 0 }
```

might be useful if the first page is really an unnumbered cover sheet. `@FirstPageNumber` must be an Arabic number even if `@PageNumbers` is set to something other than Arabic.

Some document types, such as books and technical reports with cover sheets, have a separate introductory sequence of pages preceding the main sequence. For the page numbers on introductory pages there are two options, `@IntroPageNumbers` and `@IntroFirstPageNumber`, which are exactly analogous to `@PageNumbers` and `@FirstPageNumber`. It is traditional to number introductory pages using Roman numerals, so Roman is the default value of `@IntroPageNumbers`.

Let's summarize the five options so far by looking at their values in the book setup file,

which was used to produce the present document:

```
@PageHeaders { Titles }
@PageNumbers { Arabic }
@FirstPageNumber { 1 }
@IntroPageNumbers { Roman }
@IntroFirstPageNumber { 1 }
```

The remainder of this section goes beyond these basic choices to explain how to change the detailed appearance of page headers and footers. Inevitably it gets quite a lot harder.

Pages are classified by the page header options in three ways:

1. *Odd vs. even.* The first page is odd, the second is even, the third is odd, and so on. If `@FirstPageNumber` is set to an even number, the first page will have that number, but it will still be classified as odd.
2. *Start vs. non-start.* A start page is the first page of some major part of the document (a chapter, say); other pages are non-start. The Simple header type uses a simpler definition: a page whose number is 0 or 1 is a start page, all others are non-start.
3. *Intro vs. non-intro.* Intro pages form a separate sequence of pages that precede the main (non-intro) sequence. They typically contain prefatory material such as a title page, preface, and table of contents. In a book there will always be an even number of Intro pages, even if it means that the last one is empty.

These classifications are quite independent of each other: a page could be a non-intro start odd page, or an intro non-start even page, and so on. This makes eight ($2 \times 2 \times 2$) possibilities altogether. Depending on the type of document there may also be pages that Lout will never place a page header or footer on (e.g. pages containing part titles in books).

If you choose `@PageHeaders { None }`, there are no page headers or footers, so there is nothing more to say. If you choose `@PageHeaders { Simple }`, then eight options become relevant for controlling the page headers on each of the eight kinds of pages. Here they are with their default values:

```
@OddTop { @Centre { - @PageNum - } }
@EvenTop { @Centre { - @PageNum - } }
@StartOddTop { @Null }
@StartEvenTop { @Null }
@IntroOddTop { @Null }
@IntroEvenTop { @Null }
@IntroStartOddTop { @Null }
@IntroStartEvenTop { @Null }
```

If the word Start is missing from an option name, the option applies to non-start pages; if Intro is missing, it applies to non-intro pages. Another eight options control footers in the same way:

```

@OddFoot { @Null }
@EvenFoot { @Null }
@StartOddFoot { @Null }
@StartEvenFoot { @Null }
@IntroOddFoot { @Centre @PageNum }
@IntroEvenFoot { @Null }
@IntroStartOddFoot { @Centre @PageNum }
@IntroStartEvenFoot { @Null }

```

The value of the option is an object which becomes the header or footer. It may be any object, but there are some peculiarities that will be explained now.

The full set of symbols of the BasicSetup package can be used when setting page header options (and indeed any of the options of the @BasicSetup @Use clause package), as well as symbols from special-purpose packages that have been included before this setup file. This means you can use any symbol you might reasonably expect to. But footnotes and floating figures and tables, for example, are not from BasicSetup so cannot be used.

There are five symbols of special relevance to page headers and footers: @Null, @Centre, @Center, @Right, and @PageNum.

The @Null symbol is similar to the empty object in printing as nothing, but in addition it removes the vertical space that ordinarily separates the header line from the page body. If there is no header there should be no vertical space either, so always use @Null rather than the empty object in header and footer options.

@Centre and @Center centre the following object, and @Right right-justifies it:

```
at left @Centre { - 27 - } @Right { at right }
```

produces

```
at left                - 27 -                at right
```

The objects should be enclosed in braces if they contain spaces.

The @PageNum symbol produces the number of the current page, in Arabic, Roman, etc. as specified by the @PageNumbers or @IntroPageNumbers option. @PageNum is available only within page header and footer options.

To get the *last* page into a header, so that you can have page headers like ‘Page 5 of 8’, you need @NumberOf last.page as described in Section 2.8. You might have

```
@Centre { Page @PageNum of @NumberOf last.page }
```

as the value of @EvenTop and the rest.

At this point you might like to pause and verify that the default values of the sixteen options given above produce what we said they would: no footers, and a centred page number between hyphens on every page whose number is not 0 or 1. It should be clear now what to do if you want to remove the hyphens, move the numbers to the page footer, make them bold, have them at the left on even pages and at the right on odd pages, and so on.

A different set of sixteen options applies when @PageHeaders is set to Titles or NoTitles.

Here are the eight options for headers, with their default values:

```
@RunningOddTop { @I { @MinorNum @DotSep @MinorTitle }
  @Right @B @PageNum }
@RunningEvenTop { @B @PageNum
  @Right @I { @MajorNum @DotSep @MajorTitle } }
@RunningStartOddTop { @Null }
@RunningStartEvenTop { @Null }
@RunningIntroOddTop { @Null }
@RunningIntroEvenTop { @Null }
@RunningIntroStartOddTop { @Null }
@RunningIntroStartEvenTop { @Null }
```

Some options occupy two lines, but only because they are long: as usual, the end of a line is the same as one space. Here are the options for footers:

```
@RunningOddFoot { @Null }
@RunningEvenFoot { @Null }
@RunningStartOddFoot { @Centre { Bold 0.8f } @Font @PageNum }
@RunningStartEvenFoot { @Centre { Bold 0.8f } @Font @PageNum }
@RunningIntroOddFoot { @Right @PageNum }
@RunningIntroEvenFoot { @PageNum }
@RunningIntroStartOddFoot { @Null }
@RunningIntroStartEvenFoot { @Null }
```

All these options are similar to the earlier ones, in providing one option for each of the eight kinds of pages. The names are the same except that `Running` is added to each. Remember that a start page is now one that begins a major part of the document.

In addition to the symbols described earlier for simple page headers and footers, these running header options may contain the symbols `@MajorNum`, `@MajorTitle`, `@MinorNum`, `@MinorTitle`, `@DotSep`, `@NoDotSep`, `@DotJoin`, `@NoDotJoin`, `@DashJoin`, and `@NumSep` described below.

The exact values of `@MajorNum`, `@MajorTitle`, `@MinorNum`, and `@MinorTitle` depend on the document type, but they are intended to describe what is on the current page. Here are some values typical of books:

```
@MajorNum    Chapter 2
@MajorTitle  Adding Structure to Documents
@MinorNum    2.7
@MinorTitle  Tables of contents
```

It is not possible to change the values assigned to these symbols, but the sixteen options allow you to choose whether to use them and how to arrange them, in the usual way.

The `@DotSep` symbol consumes the objects to its left and right and produces them separated by a dot and two spaces:

```
@MinorNum @DotSep @MinorTitle
```

is the same as

```
@MinorNum. @MinorTitle
```

However, if either object is empty, the dot and two spaces are omitted. It's a fine point, needed mainly for unnumbered chapters and sections. `@DotJoin` is the same as `@DotSep` but without the two spaces. `@NoDotSep` is the same as `@DotSep` but leaving out the dot, `@NoDotJoin` is the same as `@DotJoin` but again leaving out the dot, and `@DashJoin` is the same as `@DotJoin` except that '-' replaces the dot.

Lout uses `@DotSep` between numbers and titles by default. To get rid of all dots between numbers and titles it is necessary to change all occurrences of `@DotSep` in the setup file to `@NoDotSep`. There are about ten occurrences, depending on the setup file.

`@NumSep` is similar to `@NoDotSep` except that one space is used, not two, and also the order of the two parts is reversed and a dot is added if the current language is Hungarian (apparently Hungarians write '3. Table' where other people write 'Table 3'). `@NumSep` is used behind the scenes in a variety of places.

The present document was produced using `@PageHeaders { Titles }` with the default values of the sixteen options unchanged, as you might like to verify. `@PageHeaders { NoTitles }` is identical to `@PageHeaders { Titles }` except that `@MajorNum`, `@MajorTitle`, `@MinorNum`, and `@MinorTitle` are always replaced by empty objects. The description given at the beginning of this section, 'like Titles but with the titles blanked out,' is therefore accurate.

There is a `@StructPageNums` setup file option that produces structured page numbers when it is changed to Yes; that is, page numbers that include a section number, subsection number, and so on. Precisely which structure numbers are included is determined by the `@SectionNumInRunners` option and its relatives. `@PageHeaders` must be Titles when structured page numbers are used, and it is probably best to set `@SectionGap` and some similar options to 2b (meaning new page) as well. The `@NumberSeparator` setup file option (Section 2.7) affects the format of the structured page numbers.

There is a `@PageNumberFormat` setup file option that allows a uniform format to be applied to every page number. Its default value,

```
@PageNumberFormat { number }
```

just produces the number. To change the format, change the object within the braces. For example,

```
@PageNumberFormat { (number) }
```

will cause parentheses to be printed around every page number, and so on.

Chapter 5. References

The simple way to make a list of references is to put them in a numbered or tagged list at the end of your document. If you use references only rarely, that is probably the best way, but if you use them frequently this chapter will save you hours of work in the long run.

Some good general principles and many examples have been given by van Leunen [11]. Broadly speaking Lout follows her recommendations, with some unification and scaling back as is inevitable with software. Scribe [9] and L^AT_EX [7] followed the first edition of the same source, so translation from Scribe and L^AT_EX references is fairly straightforward.

5.1. Setting up a bibliographic database

The basic idea is to store your references in a separate *database file*, in a form which does not include formatting details such as font changes. This makes it easy to use the same references in many documents, and it leaves the formatting to Lout. Here is an example of a reference as it would appear in a database file:

```
{ @Reference
  @Tag { vanleunen1992 }
  @Type { Book }
  @Author { Mary-Claire van Leunen }
  @Title { A Handbook for Scholars }
  @Publisher { Oxford }
  @Edition { Revised Edition }
  @Year { 1992 }
}
```

@Reference is a symbol, and @Tag, @Type, @Author, and so on are its options. The database file as a whole consists of a sequence of references, each enclosed in braces as shown.

The @Tag option is compulsory: since you cite a reference by giving its tag, there must be one. The @Type option is also compulsory, since it says whether the reference is to a book, a journal article, or whatever, and this determines what other options are required. Section 5.4 describes all the types provided by Lout, and Section 5.6 explains how to add your own.

Lout database file names must end in .ld, so now suppose that you have made one called refs.ld and put it in the same directory as your document. Next, place

```
@Database @Reference { refs }
```

at the start of your document, just before @Doc, @Document, @Report, or whatever. Alternatively, you may place it at the end of your setup file. It informs Lout that you might be referring to @Reference symbols in database refs (that is, in file refs.ld).

If you want to maintain a central database, used by many documents, you won't want it in

the same directory as any one of them. A Unix pathname will be more appropriate:

```
@Database @Reference { "/usr/jeff/lib/refs" }
```

or whatever. Quotes are needed because of the / characters. A separate directory is probably safest anyway, since Lout creates files ending in .ld in the document directory when sorting out cross references (Section 2.8), and clearing these out using the Unix command

```
rm lout.li *.ld
```

will destroy your valuable database file if it is kept in the same directory.

With the database file created and the @Database line in place, you are ready to start citing references. The first time that the database is used, Lout will create an *index file* whose purpose is to speed up the retrieval of your references. Thanks to this file you can have hundreds or even thousands of references in your database, without slowing Lout down very much. However, whenever you change your database file *you must remove its corresponding index file*, so that Lout knows to create it afresh.¹ The index file is stored in the same directory as the database file, and it has the same name except that it ends in .li rather than .ld (e.g. refs.li).

If a separate database file is not convenient for some reason, perhaps because you need a self-contained document in a single file, the @Reference symbols may be incorporated into the document itself, anywhere that ordinary text may appear. Nothing will appear where they are typed in, but Lout will notice them and treat them as if they had come from a database file. In this case no @Database symbol is needed unless you are referring to a database as well.

You may have multiple databases, like this:

```
@Database @Reference { myrefs }
@Database @Reference { "/usr/pub/refs/theoryrefs" }
```

Lout will search the databases in the order you list them.

5.2. Citation

To cite one or more references, use the @Cite symbol like this:

```
This feature is beyond our scope @Cite { $kingston1995lout.expert, page 97 }.
```

The following object must be enclosed in braces. It may be an arbitrary object as usual. Within it the \$ character is a symbol with a special meaning: it causes a citation to be made of the reference whose @Tag option is the word following the \$ symbol:

```
This feature is beyond our scope [5, page 97].
```

The reference itself will appear automatically in a reference list at the end of the document, and the citation(s) will be enclosed in brackets as shown. There is no need to write

¹Depending on how it was installed on your system, Lout may be able to use the time of last modification of the database file and its index file to determine automatically whether the index file needs to be created afresh, thus saving you the trouble of removing it. You can find out whether this is true of your system by typing the command `lout -V`.

`kingston1995lout.expert`}, as would normally be the case, because within `@Cite` special arrangements are made to prevent commas and semicolons from being a nuisance.

A reference may be cited many times, but it will appear in the reference list only once. The references will ordinarily be sorted by tag and labelled with Arabic numbers, although this can be changed by setting options in the setup file (Section 5.5).

If you are making a book, there is a `@ChapCite` symbol which is the same as `@Cite` except that its references come out at the end of the current preface, introduction, chapter, or appendix, rather than at the end of the document.

It is quite all right to cite a reference from within a footnote, figure, table, or index entry. The reference will appear in the closest reference list following the citation point in the final printed document, or if there is no such list, the closest preceding reference list. This is fine in documents with just one reference list; but when using `@ChapCite` in books, if the citation point appears after the intended reference list (because the footnote or figure has floated past the reference list at the end of the chapter), the reference will come out in the wrong list.

Although it is frowned upon by the authorities, some people include references which are not cited anywhere in the body of their document. For this there is `@NoCite`:

```
... our scope @NoCite { $kingston1995lout.expert $kingston1993lout.design }.
```

produces

```
... our scope.
```

with the `@NoCite` symbol and any preceding space removed. The references will nevertheless appear in the reference list as usual. Note that if you put commas between the references inside `@NoCite` you will get commas in the output (so don't). There is a `@NoChapCite` symbol that combines `@NoCite` and `@ChapCite`. For compatibility with previous versions of Lout, there is a `@Ref` symbol:

```
@Ref kingston1995lout.expert
```

is the same as `@Cite { $kingston1995lout.expert }` without the brackets. There are analogous `@ChapRef`, `@NoRef`, and `@NoChapRef` symbols, which are not recommended.

The `@RefPrint` symbol will print a reference on the spot:

```
@RefPrint kingston1995lout.expert
```

has result

```
Jeffrey H. Kingston. An Expert's Guide to the Lout Document Formatting System (Version 3). Basser Department of Computer Science, University of Sydney, 1995.
```

unrelated to any reference list. For example,

```

@Heading { Journal Articles }
@NumberedList
@LI @RefPrint kingston1985tree
...
@LI @RefPrint kingston1993lout.design
@EndList

```

might appear in someone's resume.

5.3. Labelled (as opposed to numbered) references

Lout ordinarily assigns a number to each reference, and prints this number beside the reference in the reference list and at the point(s) of citation. There is a way to make Lout use a label of your choice instead of a number for each reference. First change the following setup file options to the values shown (these options are explained in Section 5.5):

```

@RefCiteLabels { @Label }
@RefListLabels { @Label. }
@RefListLabelWidth { 4.00f }
@RefListSortKey { @Label }

```

Then make sure that every reference you cite has a @Label option:

```

{ @Reference
  @Tag { kingston1995lout.expert }
  @Type { TechReport }
  @Label { Kin94 }
  ...
}

```

@Label may contain several words, and even font changes, but not an arbitrary object.

The effect of these changes is that your references will now be labelled with their @Label options instead of with numbers, and they will be sorted by label instead of by tag. However, tags are still used when citing.

The big problem with labels is that they vary from document to document, either because of a change of style or because the usual first few letters of the authors' names plus year has to be augmented with a, b, c etc. to distinguish publications by the same authors in the same year. To help you overcome these problems, the \$ symbol has a label option:

```

@Cite { $ label { Kin94a } kingston1995lout.expert, ... }

```

The @Ref and @ChapRef symbols also have a label option. If you use this option, it will be used to label the reference instead of the @Label option from the @Reference symbol (indeed, the @Reference symbol need have no @Label option in this case). But note that using label does not itself give you labelled references; you get them with the setup file options as explained above.

If your labels turn out to be too wide for the space allowed for them in the reference list, you have two alternatives. One is to increase the @RefListLabelWidth setup file option shown above,

since it determines this space. The other is to change the @RefListFormat setup file option to DropLabels, which produces drop items:

Kin94a.

Jeffrey H. Kingston. *An Expert's Guide to the Lout Document Formatting System (Version 3)*. Basser Department of Computer Science, University of Sydney, 1995.

Then it won't matter how wide your labels are.

5.4. Constructing database entries

Here is the complete, fixed list of options that you may give to the @Reference symbol:

{ @Reference	
@Tag {}	Used to cite this reference
@Type {}	The type of reference, for example Book, Article
@Abstract {}	Not used, intended to hold an abstract
@Address {}	The address of a publisher, organization, or institution
@Annote {}	Not used, intended for annotations
@Author {}	The author(s) or editor(s)
@Day {}	The day of the month, for newspaper articles
@Edition {}	The edition, for example Second Edition
@HowPublished {}	How something strange has been published
@InAuthor {}	The author of the work that the cited work appears within
@InTitle {}	The title of the work that the cited work appears within
@Institution {}	The institution or school
@Journal {}	The journal name
@Keywords {}	Not used, intended to hold keywords
@Label {}	The label of a labelled reference
@Month {}	The month of publication or writing
@Note {}	Any additional helpful information
@Number {}	The number of a technical report
@Organization {}	The organization sponsoring the work
@Page {}	Page number if only one, for example 23
@Pages {}	Page numbers if more than one, for example 23--47
@Pinpoint {}	A point or part of the work, for example Chapter VI
@Publisher {}	The publisher of the work
@Title {}	The title of the work
@TitleNote {}	Additional title information (series, editor, etc.)
@TRType {}	The type of a technical report, for example Research Note
@URL {}	The URL of the reference
@Volume {}	The volume of a journal
@Year {}	The year of publication or writing
}	

Every reference may contain any of these options, although, depending on the @Type option, only some will be printed. You can't give an option twice; in particular, multiple authors must

be placed within one @Author option, arranged as you want them to appear. Here is the complete set of values that you may give to the @Type option:

Book	TechReport	Article	InBook
Proceedings	MastersThesis		InProceedings
PhDThesis	Misc		

Each column represents one broad category of reference type: the first contains large works; the second contains small works not appearing within anything else (although possibly part of a series); the third contains small works appearing within an ongoing forum for such works; and the fourth contains small works appearing within large works. In each case, the reference may be to the work as a whole, or to one point or part of it (known as pinpointing).

Some care is needed when choosing the @Tag option, since references are both cited and sorted by tag. It is best to choose a three-part tag consisting of the first author's surname and possibly initial, the year of publication, and a brief reminder of the contents:

```
@Tag { kingston1995lout.expert }
```

Keep to lower-case letters, since mixed cases confuse the sorting, and give the full four digits of the year to avoid trouble in the year 2000. Multi-word tags are possible but not recommended.

Unusually for Lout, you can have unquoted / and ~ characters inside the @URL option:

```
@URL { ftp://ftp.cs.su.oz.au/jeff/lout }
```

In fact it is better not to use quotes because then Lout will be able to break lines at / characters, which is very useful since URLs tend to be long and prone to causing bad line breaks.

Since the types within each broad category are similar, our plan is to give one example of each and briefly note how the others differ. Here is a Book entry showing all its options:

```
{ @Reference
  @Tag { homer.odyssey }
  @Type { Book }
  @Author { Homer }
  @Title { The Odyssey }
  @TitleNote { Translated by E. V. Rieu }
  @Pinpoint { Chapter VI }
  @Pages { 102--111 }
  @Page { 102 }
  @Publisher { Penguin Books }
  @Address { Harmondsworth, Middlesex }
  @Edition { Penguin Classics Edition }
  @Month { August }
  @Year { 1942 }
  @Note { The date of composition is unknown,
but is thought to be about the tenth century BC. }
}
```

And here is what it produces:

Homer. *The Odyssey*, Chapter VI, pages 102–111, page 102. Translated by E. V. Rieu. Penguin Books, Harmondsworth, Middlesex. Penguin Classics Edition, August 1942. The date of composition is unknown, but is thought to be about the tenth century BC.

The only compulsory options are @Tag, @Type, and @Title, and Lout will carefully adjust the formatting to the right thing when you omit others. A basic book would have just @Tag, @Type, @Author, @Title, @Publisher, and @Year options.

Proceedings is similar, except you may have an @Organization or @Institution option for the sponsoring organization if you wish, and the author will either be absent or an editor:

```
@Author { P. W. Lamb, editor }
```

There is no option specifically for editors, translators, and so forth.

PhDThesis is very similar again, with @Institution instead of @Publisher, and the phrase ‘Ph.D. thesis’ appearing by magic in the right spot. Like all words and phrases introduced automatically by Lout, it will be translated into the current language if this is not English.

Moving now to the second broad category, here is a typical TechReport:

```
{ @Reference
  @Tag { christofides1976tsp }
  @Type { TechReport }
  @Author { Christofides, N. }
  @Title { Worst-case analysis of a new heuristic
for the travelling salesman problem }
  @Number { 388 }
  @Institution { Graduate School of Industrial
Administration, Carnegie-Mellon University }
  @Address { Pittsburgh, PA }
  @Year { 1976 }
}
```

Here is the result:

N. Christofides. Worst-case analysis of a new heuristic for the travelling salesman problem. Tech. Rep. 388 (1976), Graduate School of Industrial Administration, Carnegie-Mellon University, Pittsburgh, PA.

The two novelties here are the @Number option, which is the number of the report, and the ‘Tech. Rep.’ phrase. If you need some other phrase instead, use the @TRType option:

```
@TRType { Programmer’s Manual }
```

or whatever. The phrase will be ‘Master’s Thesis’ in the current language for type MastersThesis, and absent in type Misc. You may use the pinpointing options (@Pinpoint, @Page, and @Pages) and @TitleNote, @Month, and @Note in the same way as for books.

Journal articles are referenced by journal name, volume, number, and page(s):

```
{ @Reference
  @Tag { kingston1993lout.design }
  @Type { Article }
  @Author { Jeffrey H. Kingston }
  @Title { The design and implementation of the
Lout document formatting language }
  @Journal { Software---Practice and Experience }
  @Volume { 23 }
  @Pages { 1001--1041 }
  @Year { 1993 }
}
```

The result of this is

Jeffrey H. Kingston. The design and implementation of the Lout document formatting language. *Software—Practice and Experience* **23**, 1001–1041 (1993).

All are optional, as usual. Notice that @Pages and @Page refer to the whole article so are not available for pinpointing here, but you may still use @Pinpoint.

Finally, small works that appear within large works have @Author and @Title options for the work itself, and @InAuthor and @InTitle for the work that it appears within:

```
{ @Reference
  @Tag { rieu1942intro }
  @Type { InBook }
  @Author { E. V. Rieu }
  @Title { Introduction to @I { The Odyssey } }
  @InAuthor { Homer }
  @InTitle { The Odyssey }
  @Publisher { Penguin }
  @Year { 1942 }
}
```

@InAuthor would often be absent or an editor. The result is

E. V. Rieu. Introduction to *The Odyssey*. In Homer, *The Odyssey*. Penguin, 1942.

The other options are as for large works. Type InProceedings is similar to InBook.

A database usually has a long life, and some day it might find itself used in a document whose language is not the one its original compiler had in mind. For this reason, a truly meticulous compiler of database entries would enclose *all* language-specific options in @Language symbols:

```

{ @Reference
  @Tag { zimand1986size.sets.strings }
  @Type { Article }
  @Author { French @Language { M. Zimand } }
  @Title { English @Language { On the topological size of sets of random strings } }
  @Journal { German @Language { Zeitschr. f. math. Logik und Grundlagen d. Math. } }
  @Volume { 32 }
  @Pages { 81--88 }
  @Year { 1986 }
}

```

(My apologies to M. Zimand if he or she is not French.) This ensures correct hyphenation whatever the language of the document in which the reference appears.

5.5. Changing the appearance of citations and the reference list

By default, citations appear like this [5], and the reference list appears like the one at the end of this document, with the entries numbered, and sorted by their @Tag options. This section explains how to change all this, by setting options in the setup file.

For a general introduction to setup files and their options, see Section 4.1. Here we just describe the setup file options that relate to references. Here they are, with their default values:

```

@MakeReferences { Yes }
@RefCiteStyle { [cite] }
@RefCiteLabels { @RefNum }
@RefNumbers { Arabic }
@RefListFormat { Labels }
@RefListLabels { [@RefNum] }
@RefListTitle { references }
@ChapRefListTitle { references }
@RefListIndent { 0c }
@RefListRightIndent { 0c }
@RefListGap { 1.00v }
@RefListFont { }
@RefListBreak { }
@RefListLabelWidth { 2.00f }
@RefListSortKey { @Tag }

```

Setting @MakeReferences to No will cause Lout to ignore all citation symbols and omit all reference lists.

@RefCiteStyle and @RefCiteLabels combine to determine the appearance of citations. The result of each @Cite symbol is the value of @RefCiteStyle with the cite symbol replaced by the object following the @Cite symbol. For example, the default value shown above encloses each citation in brackets. The cite symbol must appear exactly once within @RefCiteStyle.

@RefCiteLabels determines the appearance of each label within the citation. Within it, the @RefNum symbol will produce the number of the reference, and you may also use any of the

options of the @Reference symbol listed at the beginning of Section 5.4:

```
@RefCiteLabels { @RefNum }      [3]
@RefCiteLabels { @Label }       [Kin93]
@RefCiteLabels { @Author, @Year } [Jeffrey H. Kingston, 1993]
```

The value of @RefCiteLabels may be any object. The @Label symbol will produce the label option of \$ or @Ref if there is one, rather than the @Label option of the reference; this label option is explained in Section 5.3.

@RefNumbers determines the kind of numbering produced by the @RefNum symbol used within @RefCiteLabels above and @RefListLabels below. Its value may be Arabic, Roman, UCRoman, Alpha, or UCAAlpha, as usual for numbering in Lout. If you don't use @RefNum, @RefNumbers has no effect.

The remaining eleven setup file options are all concerned with the appearance of the reference list. The first, @RefListFormat, determines the overall format of the list. Here is what its four possible values do:

```
@RefListFormat { NoLabels }      William Strunk and E. B. White. The Elements of Style.
                                  Macmillan. Third Edition, 1979.

@RefListFormat { Labels }        10. William Strunk and E. B. White. The Elements of
                                  Style. Macmillan. Third Edition, 1979.

@RefListFormat { DropLabels }    10.
                                  William Strunk and E. B. White. The Elements of
                                  Style. Macmillan. Third Edition, 1979.

@RefListFormat { InLabels }      10. William Strunk and E. B. White. The Elements of
                                  Style. Macmillan. Third Edition, 1979.
```

@RefListFormat is not concerned with the appearance of the labels and references, only with where they appear.

@RefListLabels determines the appearance of the labels in the reference list (and so has no effect if @RefListFormat is NoLabels). It is a combination of @RefCiteStyle and @RefCiteLabels; you can use @RefNum and all the options of @Reference within it. The default value,

```
@RefListLabels { @RefNum. }
```

produces a numbered reference list in the style of @NumberedList. Another useful value is

```
@RefListLabels { [@Label] }
```

which produces the @Label option of the reference, or the label option of the citation if there is one, enclosed in brackets. If you do switch to non-numeric labels you will need to either use DropLabels or else increase the @RefListLabelWidth option described below.

@RefListTitle determines the heading placed just before the reference list at the end of

the document:

```
@RefListTitle { Further Reading }
```

Two special values, references and bibliography, produce References and Bibliography in English and their equivalents in other languages. `@ChapRefListTitle` is the same as `@RefListTitle`, but applied to the reference list at the end of each chapter of a book when `@ChapCite` is used.

`@RefListIndent`, `@RefListRightIndent`, and `@RefListGap` determine the left indent, right indent, and gap between reference list items, analogously to the `indent`, `rightindent`, and `gap` options of the `@List` symbol (Section 2.2). `@RefListFont` and `@RefListBreak` determine the font and paragraph breaking style of the reference list. For example,

```
@RefListFont { -2p }
@RefListBreak { 1.2fx outdent }
```

switches to a smaller size with outdented paragraphs (these work well with `NoLabels`). The empty default values produce the same font and break style as in the document as a whole.

`@RefListLabelWidth` determines the distance from the left edge of the labels to the left edge of the references, when `@RefListFormat` is `Labels` or `DropLabels` (it has no effect when `@RefListFormat` is `NoLabels` or `InLabels`). This is different to `@RefListIndent`, which determines the distance from the edge of the column to the left edge of the item.

Particular care is needed when `@RefListFormat` is `Labels` and the labels are non-numeric, for then if the labels are too wide they will overstrike the references. The default value, `2.00f`, is twice the current font size. It may be changed to any length (Section 1.2). Regrettably, `Lout` is not clever enough to choose a good value by itself.

Finally, `@RefListSortKey` determines the sorting key used when ordering the reference list. The default value,

```
@RefListSortKey { @Tag }
```

sorts by tag. Another possibility is to sort by the `@Label` option:

```
@RefListSortKey { @Label }
```

As usual `@Label` will use the value of a label option to the citation if there is one. To sort by order of first citation, use

```
@RefListSortKey { @CiteOrder }
```

`@CiteOrder` is implemented in a quick and dirty way, and there are a couple of problems to watch out for if you use it. First, when you cite references more than once you get some strange intermediate error messages and results. All such problems will be gone by the end of the fifth run. Second, if you insert more citations later on, you will need to restart the whole process, by deleting the cross reference index file *lout.li*, since any late insertions get erroneously stuck on the end instead of inserted in the correct order. If things go haywire, delete *lout.li* then do five runs and they should be right again.

`@RefListSortKey` may be any sequence of words and options from the `@Reference` symbol, but not `@RefNum` for obvious reasons. A possible more elaborate sorting key is

```
@RefListSortKey { @Author:@Year:@Tag }
```

sorting first by author, then by year within each author, and finally by tag. However you are supposed to choose tags which have this effect, and that is more reliable since the modern practice is to put the authors' surnames after their given names. There seems to be little practical use for sorting keys other than @Tag, @Label, and @CiteOrder.

A colon within the @RefListSortKey option is converted by Lout into a character smaller than any printable character, which ensures that the sorting is carried out separately on the three fields. It is essential that the sort key uniquely identify the reference, because if two sort keys are equal only one of the references will be printed. The easiest way to ensure this is to always include @Tag in the sort key.

5.6. Creating your own entry types and formats

Although the set of options to the @Reference symbol (@Tag, @Type, @Author, etc.) is fixed, you can add your own reference types and change the formatting of existing types.

To do this you must be using your own setup file, as explained in Section 4.1. At the end of the setup file you will find this line:

```
@SysDatabase @RefStyle { refstyle }
```

This tells Lout to consult a database file of reference styles called refstyle.ld. These are not references, they are formatting styles, one for each reference type. The Sys in @SysDatabase means that this file is stored in the *Lout system database directory*, which is where all the standard databases are kept. To change the formatting of a reference type, or to add your own types, you need to create your own reference styles database file by copying and modifying refstyle.ld.

To find out the name of the Lout system database directory, type the Unix command

```
lout -V
```

Then, supposing that the Lout system database directory is /usr/lout/data, type

```
cp /usr/lout/data/refstyle.ld mystyle.ld
```

to place a copy of the refstyle.ld database file in your directory, renaming it mystyle.ld. Since refstyle.ld is read-only, you may also need to change the mode of mystyle.ld to be writable (by `chmod +w mystyle.ld` in Unix). Now replace

```
@SysDatabase @RefStyle { refstyle }
```

at the end of your setup file by

```
@Database @RefStyle { mystyle }
```

and Lout will read its reference styles from mystyle.ld instead of refstyle.ld. Since the two are at present identical, this has changed nothing so far; but now any changes you make to mystyle.ld will affect your document. Changing @SysDatabase to @Database makes Lout search your current directory for mystyle.ld, whereas @SysDatabase searches only the system directory.

In practice you will probably want to store your database of reference styles in some library directory, so that it can be used by many documents. A Unix pathname is appropriate for this:

```
@Database @RefStyle { "/usr/jeff/lib/mystyle" }
```

Quotes are needed because of the / characters.

The database entries within `refstyle.ld` and `mystyle.ld` might look something like this:

```
{ Book @RefStyle @Style
  { @Reference&&reftag @Open
    {
      @Author. @I @Title. @Publisher, @Year.
    }
  }
}
```

The meaning of the first two lines is beyond our scope, except that `Book` on the first line means that this is the entry which defines how references of type `Book` will be printed. Fortunately, apart from this one word these two lines are the same in every reference style entry so you don't need to understand them. The important part is in the middle:

```
@Author. @I @Title. @Publisher, @Year.
```

The meaning should be clear: first print the author option and a full stop, then the title option and another full stop in italics, and so on. To change the formatting of books, change this object. To create a new reference type, copy the entire database entry, change `Book` to a new name of your choice, and change the middle part. Don't forget to delete the index file `mystyle.li` afterwards, if there is one, so that `Lout` knows to generate it afresh.

Although the entry shown above is perfectly viable, the real entry for `Book` is much more complicated, in part because there are more options than those basic four, but mainly because the real entry goes to great lengths to do the right thing when options are omitted:

```

{ Book @RefStyle @Style
  { @Reference&&reftag @Open
    {
      { @Author. {} } @If @Author
      { @I @Title } @If @Title
      { @Word&&notitle } @If @Not @Title
      { , @Pinpoint } @If @Pinpoint
      { , @Word&&pages @NumSep @Pages } @If @Pages
      { , @Word&&page @NumSep @Page } @If @Page
      { . @TitleNote } @If @TitleNote
      { . @HowPublished } @If @HowPublished
      { . @Publisher } @If @Publisher
      { . @Organization } @If @Organization
      { . @Institution } @If @Institution
      { , @Address } @If @Address
      { . @Edition } @If @Edition
      { , @Month @Year } @If @Year @And @Month
      { , @Year } @If @Year @And @Not @Month
      { . } @If @True
      { {} URL @URL. } @If @URL
      { {} @Note } @If @Note
    }
  }
}

```

The meaning is that each object to the left of an @If will be printed only if the condition to the right of the @If is true. The condition may contain options, which are considered to be true if they are not omitted (non-empty), and it may contain @And, @Or, @Not, and @True with the usual precedence and meaning. Sub-conditions may be enclosed in braces if desired, although it is best to keep the conditions as simple as possible given the complexity of the whole setup.

The objects subject to @If are printed with no space preceding them; any space in the final print will be the result of space within them, not between them. This is why @If @True is not redundant.

The object @Word&¬itle produces No title in the current language; @Word&&pages produces pages in the current language, and so on. Consult database standard.ld for other standard words and phrases, and page 114 for @NumSep.

Chapter 6. Tables

This chapter explains how to produce tables like this one:

Value of mathematical formulae (millions of dollars)		
<i>Quadratic formula</i>	$x = \frac{-b \pm \sqrt{b^2 - 4ac}}{2a}$	3.5
<i>Binomial theorem</i>	$(a + b)^n = \sum_{k=0}^{\infty} \binom{n}{k} a^k b^{n-k}$	12

As the example shows, the tables may contain spanning columns, aligned columns, and rules, and the cells may contain arbitrary objects.¹

6.1. Getting started

The Lout definitions for table formatting² are kept in a file called `tbl`, which you must include at the start of your document if you want tables, like this:

```
@SysInclude { tbl }
@SysInclude { doc }
@Doc @Text @Begin
...
@End @Text
```

Specialized setup files, like `tbl`, are included before the main setup file (`doc` in this case). Alternatively, if you are using your own setup file, you may place the include commands within it, near the start.

To begin with a very simple example, the table

Austen	Chaucer	Donne
Balzac	Darwin	Goethe
Byron	Dickens	Homer

is produced by the following input:

¹There has been a slight change to `@Tbl`, starting with Version 3.18: if you want columns whose entries are aligned (on decimal points, equals signs, etc.), or the analogous thing with rows, you have to ask for it now, whereas before it happened automatically. See Section 6.8 for the details.

²The `tbl` package described here replaces the `tab` package of Version 3.12 and earlier. For backward compatibility the `tab` package is still available and still works as described in older versions of this documentation. Users of `tab` will find simple uses of `tbl` to be very similar, replacing `@Tab` by `@Tbl`, `@Fmta` by `aformat`, `@Col` by `@Cell`, and `!` by `|`.

```

@Tbl
  aformat { @Cell A | @Cell B | @Cell C }
{
@Rowa
  A { Austen }
  B { Chaucer }
  C { Donne }
@Rowa
  A { Balzac }
  B { Darwin }
  C { Goethe }
@Rowa
  A { Byron }
  B { Dickens }
  C { Homer }
}

```

Immediately after the @Tbl symbol, which introduces the table, comes a *format option*, aformat, describing the format of each row. It says that each row contains three cells: @Cell A, @Cell B, and @Cell C. The format option may have up to 26 cells, with names chosen freely from the upper-case letters from A to Z. The symbol | separates each cell from the next.

After the format option comes the body of the table, enclosed in braces. It consists entirely of a sequence of rows, each introduced by a @Rowa symbol and containing one entry for each cell of the format option, as shown (the row may occupy any number of lines of the input file). The entries may be arbitrary Lout objects, such as words, paragraphs, equations, figures, and so on without restriction. An entry may be omitted altogether if it is empty. Lout will choose suitable widths for the cells, and break paragraphs in the entries to the right widths.

The result of the @Tbl symbol is an object. As usual with Lout, this object may appear at any point in the document,¹ even within a paragraph or another table. Most commonly, though, tables are displayed using the @IndentedDisplay and @CentredDisplay symbols (Section 2.1):

```
@CentredDisplay @Tbl ...
```

or else they go into the @Table symbol (Section 2.6):

```

@Table
  @Caption { ... }
@Tbl ...

```

which centres them at the top of the following page and adds a caption. Note the difference between @Tbl, which builds a table, and @Table, which places an arbitrary object in an appropriate place. It's important to remember that the result is an object like any other, because from time to time one wants such things as rotated tables whose entire contents are to be italicised:

¹In rare cases, when the table occupies an entire paragraph but is not displayed, a bug in Bassier Lout causes the second column to appear much too far to the right. If this occurs, replace the very first row symbol (@Row, @Rowa, @Rowb, etc.) by @FirstRow, @FirstRowa, @FirstRowb, etc. There are also @HeaderFirstRow, @HeaderFirstRowa, @HeaderFirstRowb etc. symbols for replacing @HeaderRow, @HeaderRowa, @HeaderRowb, etc., if required.

```
90d @Rotate @l @Tbl ...
```

and it helps to remember that the full power of Lout can be brought to bear on the *entire* table.

6.2. Changing the appearance of cells

The @Cell symbol offers a few options for changing the appearance of entries placed in it. Like all options, these appear immediately after the @Cell symbol, with their values in braces:

```
@Tbl
  aformat { @Cell paint { lightgrey } font { Italic } break { clines } A }
{
  @Rowa A {
  IMPORTANT
  Do not throw stones at this notice
  }
}
```

The result here is

<p><i>IMPORTANT</i> Do not throw stones at this notice</p>
--

with a light grey background, Italic font, and clines paragraph breaking style. The paint colour may be any colour from Section 8.1.

Wherever there is a paint option in the standard packages, there is a neighbouring texture option, which causes the paint to be applied according to a given texture. For a list of available textures, consult Section 8.2; for how the texture option works, consult the description of the texture option to the @Box symbol in Section 8.3 (all texture options work in the same way). Here's an example:

```
@Tbl
  width { 2f }
  height { 2f }
  aformat {
  @Cell paint { black } texture { brickwork } A | @Cell B |
  @Cell paint { black } texture { brickwork } C | @Cell D }
  bformat {
  @Cell A | @Cell paint { black } texture { brickwork } B |
  @Cell C | @Cell paint { black } texture { brickwork } D }
{
  @Rowa
  @Rowb
  @Rowa
  @Rowb
}
```

produces¹

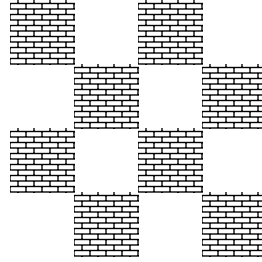

Another option, `background`, allows an arbitrary object to be placed in the background of the cell, in front of any paint but behind the entry.

Later sections introduce other `@Cell` options, for fixed-width columns, indented entries, margins, and rules. It is also possible to combine other symbols from Lout with cell formatting, by placing them between the `@Cell` symbol and its following letter, like this:

```
@Tbl
  aformat { @Cell 90d @Rotate @S A | @Cell @B grey @Colour B }
{
  @Rowa
  A { Col A }
  B { Col B }
}
```

Think of the `A` as standing for the value of the `A` option of the `@Rowa` symbol (which it does), and you'll see that this is just Lout's usual rule of symbols applying to the object that follows them. The result here is

```
Col A  Col B
Col A
```

In simple cases `@B` is easier than `font { Bold }`; the latter is useful as a default value, as we will see in a moment. Note the difference between a coloured background, obtained with `paint`, and a coloured entry, obtained using the `@Colour` symbol.

When an entry in a table consists of several paragraphs, it will usually be best to enclose it in `@OneRow`, since otherwise `@Tbl` is likely to take each paragraph as a separate row, leading to incorrect vertical spacing. A convenient way to do this is

```
aformat { @Cell @OneRow A | @Cell @OneRow B }
```

and so on.

`@Tbl` offers many places where you can set cell options. The meaning of the option is the same wherever you set it; what changes is the extent of its application. Taking the `paint` option as a representative example, the most specific place to set it is at a `@Cell` symbol as above; then

¹If you can't see any textures here, the fault is probably with your PostScript viewer. See Section 8.2.

it affects only that cell in rows formatted using that format. Alternatively,

```
@Tbl
  apaint { lightgrey }
  aformat { @Cell A | @Cell B }
```

will paint every cell in the aformat. And

```
@Rowa
  paint { lightgrey }
  A { ... }
```

will paint every cell in a particular row. To paint the entire table, use

```
@Tbl
  paint { lightgrey }
```

And finally, there is a `paint` option in the setup file (Section 6.13), which if set will paint every table in the document. When a more general setting of an option is contradicted by a more specific setting (e.g. when `@Tbl` has `paint { lightgrey }` but some cell or row has `paint { none }`), the more specific setting applies. For a precise description, see Section 6.14.

6.3. Changing the appearance of rows

We've seen that the `aformat` option of `@Tbl` determines the format of the rows introduced by the `@Rowa` symbol. There are eight row format options: `aformat`, `bformat`, and so on up to `hformat`, and for each there is a corresponding `@Row` symbol: `@Rowa`, `@Rowb`, and so on:

```
@Tbl
  aformat { @Cell @I A | @Cell @I B }
  bformat { @Cell A | @Cell B }
{
@Rowa
  A { Name }
  B { Nationality }
@Rowb
  A { Austen }
  B { English }
@Rowb
  A { Balzac }
  B { French }
}
```

The result of this is

<i>Name</i>	<i>Nationality</i>
Austen	English
Balzac	French

The first row, being a @Rowa, is formatted using aformat; the others, being @Rowb symbols, are formatted using bformat.

In addition to the eight format options of @Tbl, it is possible to specify the format of a row at the row itself, using the @Row symbol like this:

```
@Row
  format { @Cell @B A | @Cell paint { lightgrey } B }
  A { ... }
  B { ... }
```

All formats must contain the same number of cells, otherwise the table will not be rectangular.

6.4. Rules

There is a rule option for drawing a rule around a cell:

```
@Cell rule { yes }
```

Other values are no (the default), single (the same as yes), and double (for a double rule).

There are rulehorizontal and rulevertical options which draw only horizontal or vertical rules, and also ruleabove, rulebelow, ruleleft, and ruleright options:

```
@Tbl
  aformat { @Cell A | @Cell B }
{
  @Rowa
  ruleabove { yes }
  A { Commercial property }
  B { 10% }
  @Rowa
  A { Stock market }
  B { 15% }
  rulebelow { yes }
}
```

produces

Commercial property	10%
Stock market	15%

These options take the same values as rule, but draw along only one or two of the four edges.

Other options control the appearance of rules. Here they are with their default values:

```
@Tbl
  rulewidth { 0.05f }
  rulegap { 0.15f }
  rulecolour { black }
```

These say that rules are to be 0.05f wide (thick), double rules are to appear 0.15f apart, and the colour of rules is to be black. Once again, more specific versions of these symbols exist for controlling above, below, left, and right rules:

rulehorizontalwidth	rulehorizontalgap	rulehorizontalcolour
ruleabovewidth	ruleabovegap	ruleabovecolour
rulebelowwidth	rulebelowgap	rulebelowcolour
ruleverticalwidth	ruleverticalgap	ruleverticalcolour
ruleleftwidth	ruleleftgap	ruleleftcolour
rulerrightwidth	rulerrightgap	rulerrightcolour

All these options have alternative, abbreviated names; and colour may be spelt color wherever it appears. Section 6.14 has a complete summary of all spellings of all options.

To clarify exactly where the rules are drawn, let's start with a cell with no rules at all:



Above rules and left rules are drawn within the cell boundary, just touching it, with any above rule overstriking any left rule:



Below and right rules are drawn just outside the boundary of the cell, also touching it:



When a right rule is present, any above and below rules are extended by the width of the right rule, and they overstrike it:



(These diagrams were produced by @Tbl itself, using horizontal rules of width 0.8v drawn in black, and vertical rules of width 0.5v drawn in grey.) These arrangements ensure that even

thick rules produce clean corners, and also that a right rule and a neighbouring left rule exactly overstrike each other, as do a below rule and its neighbouring above rule.

6.5. Margins

The `@Cell` symbol offers a `margin` option for changing the amount of margin left between the entry and the boundary of the cell:

```
@Cell margin { 0.3f }
```

The default values are different for horizontal and vertical margins, which brings us to the `marginhorizontal` and `marginvertical` options:

```
@Cell
marginhorizontal { 0.6f }
marginvertical { 0.3f }
```

These are the default values, 0.6 and 0.3 times the current font size respectively. Another useful value is `marginvertical { 0.5vx }`, which asks for a vertical margin of half the current line separation, but measured from baseline to baseline (this is what the `x` means). This produces a separation equal to the separation of the surrounding lines:

Austen	Chaucer	Donne
Balzac	Darwin	Goethe
Byron	Dickens	Homer

This margin does not work so well when the cells contain paragraphs, diagrams or other things that could not be described as single lines.

There are `marginabove`, `marginbelow`, `marginleft`, and `marginright` options for setting margins individually. For example, sometimes you don't want the extreme left and right margins in a table, and they can be got rid of like this:

```
@Tbl
  paint { lightgrey }
  aformat { @Cell ml { 0i } A | @Cell B | @Cell mr { 0i } C }
{
  @Rowa
  A { Column A }
  B { Column B }
  C { Column C }
}
```

We've used abbreviated versions of the options' names: `ml` for `marginleft`, and `mr` for `marginright`. Every option has such an abbreviated name, made from the first letters of the parts of its full name (Section 6.14 lists all these names). The result is

Column A	Column B	Column C
----------	----------	----------

6.6. Cell width and height

Lout is quite good at choosing suitable widths for cells. It leaves narrow cells at their natural width, then uses paragraph breaking to reduce the wider cells to a common width which is as large as the available space allows:

<i>Acacia</i>	Shrub or small tree with grey-green foliage and brilliant yellow blossom in late winter.	Distributed widely throughout Australia except in the most arid parts; many varieties.
---------------	--	--

This usually looks good, but if you need something else, there is the width option:

```
@Cell width { 3c }
```

Here we have asked for a cell width of three centimetres; this includes the cell margins. When using width to fine-tune the appearance of a table wide enough to require paragraph breaking, it is best to use width to make cells narrower, not wider.

Regrettably, there is no way to request that several cells in a row be given a common width equal to the width of the widest. One simple way to approximate this is to give these cells the same width value. The width option also has a special value, expand. All cells with width { expand } are assigned a common width equal to the maximum amount permitted by the available space. For example,

```
@QuotedDisplay @Tbl
width { expand }
paint { lightgrey }
aformat { @Cell A | @Cell B | @Cell C }
{
@Rowa
A { 23.56 }
B { 98.76 }
C { 65.00 }
}
```

has result

23.56	98.76	65.00
-------	-------	-------

We have used our usual trick of making the option apply to several cells by moving it to a more general level, in this case to @Tbl. The available space can be reduced using the @Wide symbol; if we replace @QuotedDisplay @Tbl in the example above with

```
@CentredDisplay 4i @Wide @Tbl
```

the result will be

23.56	98.76	65.00
-------	-------	-------

with the total table width reduced to four inches.

There is an analogous height option which makes a cell take on a particular fixed height, again including margins. Make sure there is enough height in the cell to hold its entry when you use this option. The `expand` value is not available for height.

6.7. Indenting and struts

By default, entries appear at the left within cells, not counting the cell margin. The `indent` option causes entries to be indented horizontally. For example,

```
@Cell indent { ctr }
```

horizontally centres the entry within the cell. Other possible values are `left` (the default value), `right`, `align` (Section 6.8), or any length (for example, `2f`) meaning that much indent.

There is a corresponding `indentvertical` option for vertical indenting within the cell. It takes the same values except that `left` is renamed `top` (the default), and `right` is renamed `foot`. A common problem with vertical placement is that words that lack ascenders (parts of letters that rise up) or descenders (parts that sink down) can easily become misaligned. Looking at

```
resume  poppy  title
```

which is the result of

```
@Tbl
  aformat { @Cell A | @Cell B | @Cell C }
{
  @Rowa
  A { resume }
  B { poppy }
  C { title }
}
```

we see that the words are aligned correctly despite these worries. This is because by default `@Tbl` adds a *vertical strut* to each entry: an invisible object of zero width and height `1f`, which covers for any absent ascenders and descenders. The option

```
@Cell strut { no }
```

can be used to remove the strut; other acceptable values for this option are `yes` (the default value), and any length, which will add a strut of that length.

For completeness there is a corresponding `struthorizontal` option; it takes the same values, its default value is `no`, and it unlikely ever to be used.

6.8. Aligned columns

Columns of numbers are often presented with decimal points aligned:

5.46
3.4159
5772

To produce this you need two steps. First, indicate that you want an aligned column, using `indent { align }` on the relevant cell; and second, place a `^` symbol, which is used generally throughout Lout for alignment, just before the alignment point in each entry:

```
@Tbl
  marginvertical { 0.5vx }
  aformat { @Cell indent { align } A }
{
  @Rowa A { 5^.46 }
  @Rowa A { 3^.4159 }
  @Rowa A { 5772^ }
}
```

The equals signs of equations can be aligned in the same way.

Owing to problems behind the scenes, in a column in which one cell is labelled `indent { align }`, all the other cells have to be so labelled, otherwise Lout make a mess of things. This is a problem when we want to get a heading over the top of an aligned column: if we follow the rule, the *heading* gets aligned, which is wrong. There is no ideal solution to this problem.

What most people want is for the heading to be centred in the column, and the aligned entries to be centred in the column as a block, but Lout cannot do this. One approximation is to make the heading cell a spanning cell (Section 6.9) with `centring`, like this:¹

```
@Tbl
  marginvertical { 0.5vx }
  aformat { @StartHSpan @Cell indent { ctr } @B A | }
  bformat { @Cell indent { align } A | }
{
  @Rowa A { Head }
  @Rowb A { 5^.46 }
  @Rowb A { 3^.4159 }
  @Rowb A { 5772^ }
}
```

The spanning quarantines the centred cell, permitting `indent { ctr }` to work:

Head
5.46
3.4159
5772

But if the heading cell is wider than the aligned cells, you get this:

¹Lout does not currently accept single-column tables with `@StartHSpan`, so we've had to add an empty second column.

A Wider Heading

5.46

3.4159

5772

In other words, this will centre a heading with respect to aligned entries, but it will not centre aligned entries with respect to a heading. In these cases you could forget about `@StartHSpan` and treat the heading as an aligned entry, either by placing a `^` within it or by using

```
@Cell 0.5w @HShift A
```

which places the alignment point in the centre of the entry:

A Wider Heading

5.46

3.4159

5772

You can move the alignment point about by changing the 0.5 to something smaller or larger. Of course, all this is a poor substitute for the real thing.

6.9. Spanning columns and rows

To make a cell span across several columns, precede the `@Cell` symbol with `@StartHSpan` and replace each spanned cell's `@Cell` symbol with `@HSpan`, like this:

```
@Tbl
  rule { yes }
  aformat { @StartHSpan @Cell indent { ctr } @B A | @HSpan | @HSpan }
  bformat { @Cell A | @Cell B | @Cell C }
{
@Rowa
  A { Some famous authors }
@Rowb
  A { Austen }
  B { Chaucer }
  C { Donne }
@Rowb
  A { Balzac }
  B { Darwin }
  C { Goethe }
}
```

The result of this is

Some famous authors		
Austen	Chaucer	Donne
Balzac	Darwin	Goethe

We've used a sample of options to show how naturally these go with spanning cells: they apply to the whole cell as usual, whatever its extent. It is quite acceptable to span just some of the columns, not all of them; indeed, there may be no @HSpan symbols at all, and then the cell just spans its own column, which sounds redundant but actually has a use (Section 6.8).

Spanning rows work in the same way; the spanning cell is preceded by @StartVSpan, and the spanned cells are replaced by @VSpan:

```
@Tbl
rule { yes }
aformat { @StartVSpan @Cell @I A | @Cell B | @Cell C }
bformat { @VSpan | @Cell B | @Cell C }
{
@Rowa
A { Mathematics }
B { MATH 1001 }
C { Differential Calculus }
@Rowb
B { MATH 1002 }
C { Linear Algebra }
@Rowa
A { Computer Science }
B { COMP 1001 }
C { Introductory Programming }
@Rowb
B { COMP 1002 }
C { Introductory Computer Science }
}
```

The result of this is

<i>Mathematics</i>	MATH 1001	Differential Calculus
	MATH 1002	Linear Algebra
<i>Computer Science</i>	COMP 1001	Introductory Programming
	COMP 1002	Introductory Computer Science

Here is a notorious larger example, the 'spiral':

```

@QuotedDisplay @Tbl
  rule { yes }
{
@Row
  format { @StartVSpan @Cell A | @StartHSpan @Cell B | @HSpan }
  A { @SomeText }
  B { @SomeText }
@Row
  format { @VSpan | @Cell B | @StartVSpan @Cell C }
  B { @SomeText }
  C { @SomeText }
@Row
  format { @StartHSpan @Cell A | @HSpan | @VSpan }
  A { @SomeText }
}

```

The @SomeText symbol produces a short paragraph of text. The result is

Johnson suddenly uttered, in a strong determined tone, an apophegm, at which many will start: 'Patriotism is the last refuge of a scoundrel.'	Johnson suddenly uttered, in a strong determined tone, an apophegm, at which many will start: 'Patriotism is the last refuge of a scoundrel.'	
Johnson suddenly uttered, in a strong determined tone, an apophegm, at which many will start: 'Patriotism is the last refuge of a scoundrel.'	Johnson suddenly uttered, in a strong determined tone, an apophegm, at which many will start: 'Patriotism is the last refuge of a scoundrel.'	Johnson suddenly uttered, in a strong determined tone, an apophegm, at which many will start: 'Patriotism is the last refuge of a scoundrel.'
Johnson suddenly uttered, in a strong determined tone, an apophegm, at which many will start: 'Patriotism is the last refuge of a scoundrel.'		

It is important when constructing mind-boggling tables like this one to ensure that every format has exactly the same number of | symbols. Otherwise the number of columns will differ from row to row. The names given to the entries (A, B, C, etc.) are quite irrelevant: having a @Cell D in one row and a @Cell D in another does not mean that the cells will appear in the same column.

There is a @StartHVSpan symbol which combines the effects of @StartHSpan and @StartVSpan. You need to use it in this arrangement:

```

@StartHVSpan @HSpan @HSpan
@VSpan
@VSpan

```

The blank positions should be left empty. For example:

```

@Tbl
  rule { yes }
  aformat { @Cell A | @Cell B | @Cell C | @Cell D }
  bformat { @Cell A | @StartHVSpan @Cell i { ctr } iv { ctr } B | @HSpan | @Cell D }
  cformat { @Cell A | @VSpan | | @Cell D }
{
@Rowa
@Rowb
  B { CPU }
@Rowc
@Rowa
}

```

produces

	CPU		

This example illustrates how Lout apportions space in the presence of spanning columns. If the spanning cell is naturally narrower than the cells it spans, it is widened to their size. If it is wider (as in the example above), then the last spanned cell is widened to take up the slack. This is why the third cell is wider than the second in the first row of this example.

6.10. Vertical alignment of tables

Occasionally the vertical alignment of a table with objects to its left and right becomes an issue. Examples are hard to find, but let's say that we need to construct a symbol



and include it in running text. The obvious first attempt at a table with three rows is

```

@Tbl
  aformat { @Cell A }
  margin { 0i }
  strut { no }
{
@Rowa A { @OpenCircle }
@Rowa A { @ClosedCircle }
@Rowa A { @OpenCircle }
}

```

where `@OpenCircle` and `@ClosedCircle` produce open and closed circles (they may be defined using the `@Diag` package); but this produces  in running text, because vertical alignment is by default through the top boundary of the table. To make the alignment pass through one of the rows, replace its `@Row` symbol by a corresponding `@MarkRow` symbol. Here is the revised table, enclosed in a definition for ease of use:

```

import @TblSetup
def @AmberLight
{
  @OneRow @Tbl
  aformat { @Cell indentvertical { align } A }
  margin { 0i }
  strut { no }
  paint { no }
  rule { no }
  {
    @Rowa A { @OpenCircle }
    @MarkRowa A { @ClosedCircle }
    @Rowa A { @OpenCircle }
  }
}

```

Now when we write

produces @AmberLight in running text

we find that this definition produces $\begin{matrix} \circ \\ \bullet \\ \circ \end{matrix}$ in running text, as desired. We have enclosed the table in @OneRow to ensure that its rows will never become separated, and added some options just in case the definition is ever used with a setup file (Section 6.13) that has default painting or rules.

6.11. Multi-page tables

The tables produced by @Tbl permit page breaks (including breaking to a new column) between every two rows, except rows that have a vertically spanning cell in common. Page breaks cannot occur within rows. The choice of page breaks can either be left to Lout, or it can be forced by placing the new page symbol @NP between two rows.

To prevent page breaks within a table, precede the @Tbl symbol by @OneRow:

```
@CD @OneRow @Tbl ...
```

@OneRow is a general Lout symbol which binds the following object into a single, unbreakable row. Make sure your table is small enough to fit on one page when you do this, otherwise an error message will be printed and it will be scaled to fit. Display symbols like @CD often have this effect anyway.

To prevent a page break between two particular rows, but not in general, replace the @Row symbol of the second row with the corresponding @NoBreakRow symbol (@NoBreakRowa instead of @Rowa, @NoBreakRowb instead of @Rowb, and so on).

Some care is needed over where to put multi-page tables. They can't go within any of the display symbols, because display symbols are not clever enough to break tables between rows, even though they are sometimes able to break simpler displays. (A display symbol will scale a very high table to fit on one page, and it will go wrong on a table containing @NP.) Multi-page tables can go inside @Figure or @Table symbols, because these symbols have been set up to accept multi-page objects. Or they can go into the body text of the document at full width with

a paragraph symbol before and after, like this:

```
@DP
@Tbl ...
@DP
```

An example of this kind of multi-page table appears in Section 6.14. You can simulate an indent by means of an empty cell at the left of each row format, although in the author's opinion a multi-page table looks better at full width anyway. Lout will expand the rightmost column to the full page width; one way to prevent this is to add a | after the last cell within each format option, creating an empty extra column.

One practical problem in multi-page tables is getting the rules right. The simplest way to do this is to set `rulehorizontal` to `yes`. This places a rule above every row including the first on each page, and a rule below every row including the last on each page. There is nothing equivalent to running headers (described below) at the bottom of the page – nothing that would allow you to insert a rule after the last line of each page, but not elsewhere. (However, if you are using the `@Table` symbol, its `@Format` option can be used to do this.)

Another practical problem with multi-page tables is that of getting a heading over every page after the first. This is easy if you know where the page breaks are going to fall (if you are using `@NP`, for example), but you usually don't. To solve this problem, `@Tbl` offers the `@HeaderRowa ... @HeaderRowh` and `@EndHeaderRow` symbols. For example, the multi-page table in Section 6.14 is arranged like this:

```

@Tbl
...
{
@Rowd
  A { Option names }
  B { Default in PS, PDF }
  C { Default in plain text }
  D { Allowed values }
  rulebelow { yes }
@HeaderRowd
  A { Option names (ctd.) }
  B { Default in PS, PDF }
  C { Default in plain text }
  D { Allowed values }
  rulebelow { yes }
@Rowa
  A { paint p }
  B { none }
  D { any colour from Section {@NumberOf colour} }
...
@Rowa
  A { ruleplainchar rpc }
  C { . }
  D { any simple word e.g. @Code + }
  rulebelow { yes }
@EndHeaderRow
}

```

`@HeaderRowd` is exactly like `@Rowd`, except that the row is not printed at all where it occurs; instead, it is saved up and used as a running header on subsequent pages.

The `@EndHeaderRow` symbol goes where a `@Row` symbol might go. Notice that it does not end with a letter between a and h, and that it has no options. Its effect is to cancel the closest preceding `@HeaderRowa ... @HeaderRowh` symbol. If you forget it, the result is bizarre: the header row will remain in effect, and then every page from this point on will have the running header, even though the table ended long before.

There may be any number of header rows saved up at any moment, all to be printed at the top of subsequent pages. Having `@EndHeaderRow` allows them to be ‘nested.’ For example,

```

@HeaderRowa ...
@HeaderRowb ...
@EndHeaderRow
@HeaderRowb ...
@EndHeaderRow
@EndHeaderRow

```

could be used in a table to say that the entire table has the first header row; and that the first part also has the second header row, but that subsequent parts of the table have their own, different second header row, but still the same first header row.

Certain kinds of objects are not allowed in header rows, and Lout will complain and quit if you try to put them there. Galleys (e.g. @FootNote and @Index) are not allowed, nor are cross references (e.g. @NumberOf and @PageOf), nor are @HEExpand, @VExpand, or @Scale in the form that works out its own scale factor. Spanning symbols (@StartHSpan, @StartVSpan etc.) work well in header row formats, however.

Header rows have some other peculiarities, not likely to trouble the ordinary user but worth pointing out. Header rows are taken account of by Lout when deciding column widths, whether they are actually printed or not. Basser Lout copies running header rows into the table after each page break, with no check on whether the next page has enough space to accommodate them, so if your running headers are so high that there is no room for ordinary rows on the page after they are inserted, then the document will never end.

6.12. Plain text tables

Tables work well with plain text output (Section 3.6):

```

.....
. Johnson          . Johnson suddenly uttered, in .
. suddenly        . a strong determined tone, an .
. uttered,        . apophegm, at which many will .
. in a strong     . start: 'Patriotism is the .
. determined     . last refuge of a scoundrel.' .
. tone, an       .                               .
. apophegm, at   .                               .
. which many     .                               .
. will start:    .                               .
. 'Patriotism    . Johnson          . Johnson          .
. is the last    . suddenly        . suddenly        .
. refuge of a     . uttered,        . uttered,        .
. scoundrel.'   . in a strong     . in a strong     .
.                . determined     . determined     .
.                . tone, an       . tone, an       .
.                . apophegm, at   . apophegm, at   .
.                . which many     . which many     .
.                . will start:    . will start:    .
.                . 'Patriotism    . 'Patriotism    .
.                . is the last    . is the last    .
.                . refuge of a     . refuge of a     .
.                . scoundrel.'   . scoundrel.'   .
.                .                .                .
.                .                .                .
.....
. Johnson suddenly uttered, in .
. a strong determined tone, an .
. apophegm, at which many will .
. start: 'Patriotism is the .
. last refuge of a scoundrel.' .
.                               .
.                               .
.....

```

This table was produced by a separate run of Lout and pasted into this document.

@Tbl changes the default values of several options when used in a plain text document:

```
@Tbl
marginvertical { 2f }
marginhorizontal { 2s }
rulehorizontalwidth { 1f }
ruleverticalwidth { 1s }
rulehorizontalgap { 0f }
ruleverticalgap { 0s }
```

When using plain text it is advisable to make vertical distances whole multiples of 1f, and horizontal distances whole multiples of 1s, since this avoids fractional spacing which cannot be successful in plain text files and produces quite messy results. There is also a `ruleplainchar` option for changing the character used to draw rules. For example,

```
@Tbl
ruleplainchar { - }
```

would be a good choice if you plan to draw only horizontal rules. This option can be set anywhere as usual.

If you do use rules it is worth pondering the implications of the last part of Section 6.4. Right and below rules are drawn outside the boundary of the cell, which is unimportant in ordinary output, but means that they will appear one space to the right and one line below the cell in plain text output. This explains the slight asymmetry in the example above; you can correct it with

```
@Tbl
marginright { 1s }
marginbelow { 1f }
```

but you still have to worry about rules at the extreme right of the page going off the edge, and rules below the last line bumping into whatever follows the table. The first can be fixed by not using full width tables with right rules; the second by inserting an extra `@DP` after a table that ends with a below rule.

6.13. Changing the overall format

All of the options apart from the format options can be changed in the `tbl` setup file, in which case the new values become the default values for every table in the document. This section explains how to do it. Changing options in the setup file can save a lot of time, but its more important purposes are to promote consistency and to allow document-wide formatting changes to be carried out easily.

The first step is to obtain your own copy of the setup file, `tbl`, from the Lout system include directory. You can find out where that is by typing

```
lout -V
```

This prints out various things about Lout. Supposing that it says that the Lout system include directory is `/usr/lout/include`, for example, you can copy the setup file into your current directory, renaming it `mytbl`, with the Unix command

```
cp /usr/lout/include/tbl mytbl
```

or its equivalent on your system. You will also need to make mytbl writable.

The next step is to replace the `@SysInclude { tbl }` line at the start of your document with `@Include { mytbl }`. This causes Lout to read your copy of the setup file, not the one in the system include directory. Since the two files are currently identical, this has changed nothing so far, but now you can change the options within mytbl and the changes will affect your document.

Your copy of the setup file has some lines beginning with `#` that are ignored by Lout, and then it has `@SysInclude { tblf }`. This line tells Lout to read file `tblf` which contains the definition of the `tbl` package, so it should not be changed. After it comes the `@TblSetup @Use` clause, which looks like this:

```
@Use { @TblSetup
  # paint { none }
  # font { }
  # break { }
}
```

Only a few of the options are shown here. To change a setup file option, delete the `#` in front of it and change the value. For example, suppose you want all table entries two points smaller than the surrounding text:

```
@Use { @TblSetup
  # paint { none }
  font { -2p }
  # break { }
}
```

This relative specification of font size is available anywhere, not just in setup files (Section 1.6).

Some setup file options contain values which use the `@OrIfPlain` symbol:

```
marginvertical { 0.3f @OrIfPlain 1f }
```

This means that the value of `marginvertical` is to be `0.3f` usually, but `1f` in plain text documents. Feel free to leave these symbols there when you change a value, or delete them if you prefer.

6.14. Summary of options

This summary applies to all `@Tbl` options except the format options described in Section 6.3. Here is the complete list of these options, one option per line, showing its alternative spellings, default values (PostScript and PDF, and plain text) from the setup file, and allowed range of values. Where one option is indented below another, it means that the indented option is a specialized version of the other, which affects its default value. For more on this see below.

<i>Option names</i>	<i>Default in PS, PDF</i>	<i>Default in plain text</i>	<i>Allowed values</i>
paint p	none		any colour from Section 8.1

<i>Option names (ctd.)</i>	<i>Default in PS, PDF</i>	<i>Default in plain text</i>	<i>Allowed values</i>
texture t	solid		any texture from Section 8.2
background bg			any object
font f			any font e.g. Helvetica Slope -2p
break b			any break e.g. ragged nohyphen
width w			expand or any length e.g. 5c
height h			any length e.g. 3c
indent i	left		left, ctr, align, mctr, right, or any length
indentvertical iv	top		top, ctr, align, mctr, foot, or any length
strut s	yes	yes	no, yes, or any length
struthorizontal sh	no	no	no, yes, or any length
margin m			any length
marginhorizontal mh	0.6f	2s	any length
marginleft ml			any length
marginright mr			any length
marginvertical mv	0.3f	2f	any length
marginabove ma			any length
marginbelow mb			any length
rule r	no	no	no, yes, single, or double
rulehorizontal rh			no, yes, single, or double
ruleabove ra			no, yes, single, or double
rulebelow rb			no, yes, single, or double
rulevertical rv			no, yes, single, or double
ruleleft rl			no, yes, single, or double
ruleright rr			no, yes, single, or double
rulewidth rw	0.05f		any length
rulehorizontalwidth rhw		1f	any length
ruleabovewidth raw			any length
rulebelowwidth rbw			any length
ruleverticalwidth rvw		1s	any length
ruleleftwidth rlw			any length
rulerightwidth rrw			any length
rulegap rg	0.15f		any length
rulehorizontalgap rhg		0f	any length
ruleabovegap rag			any length
rulebelowgap rbg			any length
ruleverticalgap rvg		0s	any length
ruleleftgap rlg			any length
rulerightgap rrg			any length
rulecolour rulecolor rc	black		any colour from Section 8.1

<i>Option names (ctd.)</i>	<i>Default in PS, PDF</i>	<i>Default in plain text</i>	<i>Allowed values</i>
rulehorizontalcolour	rulehorizontalcolor	rhc	any colour from Section 8.1
ruleabovecolour	ruleabovecolor	rac	any colour from Section 8.1
rulebelowcolour	rulebelowcolor	rbc	any colour from Section 8.1
ruleverticalcolour	ruleverticalcolor	rvc	any colour from Section 8.1
ruleleftcolour	ruleleftcolor	rlc	any colour from Section 8.1
rulerrightcolour	rulerrightcolor	rrc	any colour from Section 8.1
ruleplainchar	rpc	.	any simple word e.g. +

There are seven places where these options may be given, counting the setup file (Section 6.13). To make it clear that this summary applies to any of these options, we illustrate the seven places with a fictitious option called option:

```
@Use { @TblSetup
  option { 1 }
}

@Tbl
  option { 2 }
  aoption { 3 }
  aformat { @Cell option { 4 } A }
{
  @Rowa
    option { 5 }
  @Row
    option { 6 }
    format { @Cell option { 7 } A }
}
```

Each occurrence of option is of course optional. If there are none, the default value given in the table above applies. For any other combination of absent and present options, the value that applies is the present and relevant one with the largest number in the illustration just above. But before applying this rule, any general options must be thought of as being replaced by their more specialized versions:

```
rulehorizontal { yes }
```

is equivalent to

```
ruleabove { yes }
rulebelow { yes }
```

for example. Conflicts are resolved in the logical way:

```
margin { 0.5f }
marginleft { 0.0f }
```

is equivalent to the four specialized options

```
marginabove { 0.5f }
```

```
marginbelow { 0.5f }
```

```
marginleft { 0.0f }
```

```
marginright { 0.5f }
```

General options are really just abbreviations for sets of specialized options.

Chapter 7. Mathematics

This chapter explains how to produce mathematics in Lout, using the `@Math` symbol¹ like this:

```
@Math { int from { 0 } to { 1 } dx over sqrt {1 - x sup 2} = pi over 2 }
```

This example produces

$$\int_0^1 \frac{dx}{\sqrt{1-x^2}} = \frac{\pi}{2}$$

The `@Math` symbol looks after all the details of spacing for you, and it provides several hundred mathematical symbols.

7.1. Getting started

The Lout definitions for the `@Math` symbol are accessed via a setup file called `math`, which you must include at the start of your document if you want mathematics, like this:

```
@SysInclude { tbl }  
@SysInclude { math }  
@SysInclude { doc }  
@Doc @Text @Begin  
...  
@End @Text
```

This shows what to do if you want both tables and mathematics, but you may leave out the line for tables if you don't want them. Setup files for specialized packages, such as `tbl` and `math`, are best included before the main setup file, but may be included in any order.

With the `math` file included, you may write

```
@Math { ... }
```

at any point in your document, and the symbols of `@Math` will be available between the braces. Any symbols available outside continue to be available inside, which means that mathematics may be freely mixed with other symbols.

The `@Math` symbol may appear anywhere; its job is to produce an object containing mathematics, and it neither knows nor cares where that object goes. To display mathematics, use a display symbol like `@IndentedDisplay` or `@CentredDisplay` (Section 2.1). For example,

¹`@Math` follows the equation formatting rules of D. E. Knuth's \TeX system. Prior to Version 3.37 of Lout, this chapter described a symbol called `@Eq` which was similar to `@Math` but less faithful to those rules. For backward compatibility the `@Eq` symbol is still available and still works exactly as described in the old documentation, but there is no reason to use it in new documents.

`@CentredDisplay @Math { int from { 0 } to { pi } sin ' x = 0 }`

produces

$$\int_0^{\pi} \sin x = 0$$

There are also symbols for aligned and numbered displays (Section 7.4).

The `@Math` symbol sets the mathematics in *display style*, a style suited to displays. To get mathematics within a paragraph, it is best to use a variant of `@Math` called `@M`. The value of `@M { ... }` will be kept together on one line, and it will appear in *text style*, a more compact style suited to mathematics within paragraphs.

Throughout this chapter we show the Lout input at the left, and its result at the right:

`@Math { {x sup 2 + y sup 2} over 2 }` $\frac{x^2 + y^2}{2}$

Subsequent examples will omit the enclosing `@Math { ... }`.

7.2. Commonly used symbols

`@Math` prints characters in the fonts appropriate for mathematics:

`x - 2` $x - 2$

Here x is in *italic*, 2 is in *Roman*, and $-$ is from the *Symbol* font. The character $-$ is a *symbol* which stands for $-$, and 2 is also a *symbol*, standing for 2 . `@Math` offers a vast array of symbols:

Omega delta integral partial club $\Omega\delta\int\partial\clubsuit$

This section introduces the most commonly used ones; Section 7.6 has the full list.

Symbols whose names are made from letters should be separated from each other by at least one space or end of line, as was done above, or else `@Math` will become confused:

Omegadelta *Omegadelta*

Symbols whose names are made from digits and punctuation characters can, however, be run together with each other and with symbols made from letters:

Omega-delta<=2 $\Omega - \delta \leq 2$

This rule applies throughout Lout (Section 1.3).

Some symbols join objects together in mathematical ways:

`x sub 2` x_2

Here the `sub` symbol has taken the object just to its left, and the object just to its right, and joined them into one object in the form of a subscript. The two objects are called the left and right

parameters of sub, and they may be arbitrary Lout objects.

Similar symbols include sup for superscripting, over for built-up fractions, and sqrt for square roots. The - symbol used earlier is an example of a *binary operator* symbol, and <= is a *relation* symbol. These take the objects to their left and right and display them as shown; it's hard to see, but there is slightly more space around relations than around binary operators. There are also *large operator* symbols which take from and to options and set them as limits:

$$\text{sum from } \{ i=0 \} \text{ to } \{ n \} i \qquad \sum_{i=0}^n i$$

As usual in Lout, options are optional, but when given, their values must be enclosed in braces as shown. Section 7.6 has the full list of large operator symbols.

All these symbols may be used together to produce complicated mathematics very easily:

$$\text{sqrt } \{ x \text{ sup } 2 + y \text{ sup } 2 \} \text{ over } 2 \qquad \frac{\sqrt{x^2 + y^2}}{2}$$

Braces are used in the usual way for grouping. Leaving them out creates ambiguities:

a sup b over c

There are two possible interpretations for this:

$$\{ a \text{ sup } b \} \text{ over } c \qquad \frac{a^b}{c}$$

$$a \text{ sup } \{ b \text{ over } c \} \qquad a^{\frac{b}{c}}$$

@Math chooses between them in the following way. Every symbol that takes a parameter also has a *precedence*, which is a number defined in Section 7.6. The symbol with the higher precedence wins the object lying between them. White space between two objects is considered to be a symbol whose precedence is lower than that of any @Math symbol. If two symbols of equal precedence compete for an object, the association is towards the left.

In the above case the first interpretation is chosen, because sup has higher precedence than over. When in doubt, use braces to make the grouping clear.

7.3. Matrices

The matrix symbol builds an array of objects:

$$\begin{array}{l} \text{matrix} \\ \text{atleft } \{ \text{b\lpar } \} \\ \text{atright } \{ \text{brpar } \} \\ \{ \\ \text{row col } x \text{ sup } 2 \text{ col } y \text{ sup } 2 \text{ col } z \text{ sup } 2 \\ \text{row col } x \text{ col } y \text{ col } z \\ \text{row col } 1 \text{ col } 1 \text{ col } 1 \\ \} \end{array} \qquad \begin{pmatrix} x^2 & y^2 & z^2 \\ x & y & z \\ 1 & 1 & 1 \end{pmatrix}$$

The `atleft` and `atright` options place vertically scaled versions of their values at each side; if either is omitted the value is taken to be an empty object of zero width. Although `blpar` and `brpar` are used here, since the options are vertically scaled it would also be reasonable to use just

```
matrix
  atleft { ( }
  atright { ) }
```

The right parameter of `matrix` is the array itself. It must be enclosed in braces. It is a sequence of rows introduced by row symbols; each row is a sequence of objects introduced by col symbols. The row and col symbols have low precedence (Section 7.6), but not as low as white space between objects, so it is safest to enclose the entries in braces, except in simple cases.

Entries built with the `col` symbol have their objects centred in the column. Also available are `lcol` for left-justified entries, `ccol` meaning the same as `col`, `rcol` for right-justified entries, and `mcol` for alignment along column marks. Each column may contain entries of different kinds, except that `mcol` does not work well with any other sort.

When several matrices appear side by side, slight differences in height can cause an unsightly appearance:

$$\begin{pmatrix} a_{11} & a_{12} \\ a_{21} & a_{22} \end{pmatrix} \begin{pmatrix} b_{11} & b_{12} \\ b_{21} & b_{22} \end{pmatrix} = \begin{pmatrix} c_{11} & c_{12} \\ c_{21} & c_{22} \end{pmatrix}$$

To assist in resolving this problem, the `matrix` symbol has a `strut` option, which causes a strut to be inserted into every row, guaranteeing that every row has height at least equal to the height of the strut. By using

```
matrix
  strut { Yes }
  ...
```

in each of the three matrices above, the result is improved to

$$\begin{pmatrix} a_{11} & a_{12} \\ a_{21} & a_{22} \end{pmatrix} \begin{pmatrix} b_{11} & b_{12} \\ b_{21} & b_{22} \end{pmatrix} = \begin{pmatrix} c_{11} & c_{12} \\ c_{21} & c_{22} \end{pmatrix}$$

By default, the strut has height `0.5f` (half the current font size) both above and below the axis of the row. This can be changed by giving any length as the value of the `strut` option: `strut { 2.0c }` for two centimetres above and below the axis, and so on.

Some symbols are defined which produce ‘matrices’ with commonly needed `atleft` and `atright` options already set for you:

$$\text{fmatrix} \{ \{n+1\} \text{ over } 2 \} \quad \left[\frac{n+1}{2} \right]$$

As this example shows, these symbols are very useful for getting large scaled delimiters around things that aren’t necessarily matrices at all. Section 7.6 has the full list of these symbols.

Every fragment of mathematics has an *axis* running through it which is used to position it vertically with respect to nearby objects. In the Expert's Guide to Lout [5] this is called a *row mark*, but we'll stick with *axis*. Here are some examples with the axis shown as a dashed line:

$$-x^2- \quad -+- \quad -\frac{1}{\sqrt{1-4x^2}}-$$

When these objects are placed adjacent to one another, their axes are merged:

$$-x^2+\frac{1}{\sqrt{1-4x^2}}-$$

Most of the time you do not need to think about vertical positioning, because for most objects there is just one sensible place for the axis to go, and Lout puts it there.

Matrices and the delimiters that enclose them are the two exceptions. Lout makes the axis of a matrix pass through its exact centre, and it shifts the axes of delimiters so that they exactly enclose the thing delimited. These choices are never disastrous, but there are other possibilities that might be better sometimes.

The axis of a matrix could reasonably be set to the axis of any of its rows:

$$\begin{array}{ccc} -x^3-y^3-z^3- & x^3 & y^3 & z^3 \\ x^2 & y^2 & z^2 & \\ x & y & z & \end{array} \quad \begin{array}{ccc} x^3 & y^3 & z^3 \\ -x^2-y^2-z^2- & & \\ x & y & z & \end{array} \quad \begin{array}{ccc} x^3 & y^3 & z^3 \\ x^2 & y^2 & z^2 \\ -x- & -y- & -z- \end{array}$$

Alternatively, it could be set to where Lout usually places it, through the exact centre:

$$\begin{array}{ccc} x^3 & y^3 & z^3 \\ -x^2-y^2-z^2- & & \\ x & y & z \end{array}$$

Delimiters could reasonably keep the axes that they naturally have (approximately through their centres, but not exactly):

$$-\left(\frac{1}{\sqrt{1-4x^2}}\right)-$$

or they could have their axes moved in the way that Lout usually does, to the point which allows them to evenly cover the thing delimited:

$$-\left(\frac{1}{\sqrt{1-4x^2}}\right)-$$

Altogether then there are four possibilities when these two alternatives interact:

	Matrix axis uses row axis	Matrix axis passes through centre
Delimiter keeps its axis	$-\left(\frac{1}{\sqrt{1-4x^2}}\right)-$	$-\left(\frac{1}{\sqrt{1-4x^2}}\right)-$
Delimiter axis shifted	$-\left(\frac{1}{\sqrt{1-4x^2}}\right)-$	$-\left(\frac{1}{\sqrt{1-4x^2}}\right)-$

To supply these possibilities, the matrix symbol and all its variants (fmatrix etc.) have two options whose values may be yes or no:

```
matrix
  userow { no }
  shiftdelim { yes }
{
  ...
}
```

The `userow` option determines whether the axis of the matrix will use a row axis; the default is not to, i.e. to centre the axis. The `shiftdelim` option determines whether the axis of the delimiter will be shifted so that the delimiter evenly covers the thing delimited; the default is to do this.

If `userow` is yes, the next question is which row's axis to use to make the overall axis. If you do nothing, the first (or only) row's axis becomes the overall axis. To select some other row instead, replace the row symbol that precedes the row by `axisrow`:

```
matrix userow { yes } {
  row      col x sup 3  col y sup 3  col z sup 3
  axisrow  col x sup 2  col y sup 2  col z sup 2
  row      col x        col y        col z
}
```

The result of this is

$$\begin{array}{ccc} x^3 & y^3 & z^3 \\ -x^2 & -y^2 & -z^2 \\ x & y & z \end{array}$$

with the axis through the second row as desired.

7.4. Displaying equations

The result of the `@Math` symbol is an object which, according to the golden rule (Section 1.2), may appear anywhere: inside a paragraph, inside a table, and so on. In particular, equations are often displayed using the `@CentredDisplay` or `@IndentedDisplay` symbols from Section 2.1:

`@IndentedDisplay @Math { ... }`

Now displayed equations are often numbered, and often aligned with one another on their equals signs. For this there are special display symbols which are the the subject of this section. These symbols can align and number any display at all, but since in practice they seem to be used only with equations, we discuss them here rather than in Section 2.1 where they really belong.

Let's begin by looking at a first example of a numbered display:

$$F_n = F_{n-1} + F_{n-2} \quad (7.4.1)$$

After the display we might have some more text for a while, and then we might want a second display, aligned on its equals sign with the first, and also numbered in sequence with it:

$$F_n - F_{n-1} = F_{n-2} \quad (7.4.2)$$

Notice that the two displays are centred as a block as well as aligned. Altogether there are four ways in which displays vary:

- A display can be raw or not raw (see below);
- It can be a `@Display`, `@LeftDisplay`, `@IndentedDisplay`, `@QuotedDisplay`, `@CentredDisplay`, `@CenteredDisplay`, or `@RightDisplay`;
- It can be aligned or not aligned;
- It can be numbered or not numbered.

All possible combinations are allowed. The display that has everything is called

`@RawCentredAlignedNumberedDisplay`

By leaving out some or all of Raw, Aligned, and Numbered, and by changing or leaving out Centred, we get all these combinations. The two displays given earlier were made like this:

... a first example of a numbered display:

`@BeginAlignedDisplays`

`@CentredAlignedNumberedDisplay`

`@Tag { fibeq }`

`@Math { F sub n ^= F sub {n-1} + F sub {n-2} }`

After the display we might ... numbered in sequence with it:

`@CentredAlignedNumberedDisplay @Math { F sub n - F sub {n-1} ^= F sub {n-2} }`

`@EndAlignedDisplays`

Notice that the two displays are centred ...

All numbered displays have an optional `@Tag` option which is used for cross referencing (see Section 2.8). Alignment and numbering work quite independently; they don't have to start or end together, and there can be non-aligned and non-numbered displays among the others.

When aligned displays are used, it is necessary to indicate where the aligned group begins and ends, by placing `@BeginAlignedDisplays` just before the first, and `@EndAlignedDisplays`

just after the last. The alignment points are indicated by preceding them by the symbol `^`, so you aren't restricted to aligning at equals signs. `@BeginAlignedDisplays` and `@EndAlignedDisplays` cannot span across several sections or subsections: the equations aligned by them must lie within a single large-scale structure symbol.

In our example of aligned and numbered displays, the two displays were separated by some ordinary text. Very often, though, aligned displays follow directly after each other. This is a problem, because if you have one display directly following another there will be too much vertical space between them. This problem was mentioned in Section 2.1, and the recommended solution was to use a list. However, there are no aligned or numbered (in this sense) lists.

Fortunately, each display symbol has a 'raw' version, which means that no space is inserted above or below the display. Instead, you must insert it yourself using paragraph symbols:

```
preceding text
@DP
@RawAlignedDisplay @Math { ... }
@DP
@RawAlignedNumberedDisplay @Math { ... }
@DP
following text
```

Raw and non-raw displays may be numbered and aligned together.

Numbered displays are numbered automatically. Depending on where in the document they appear, the number might include a chapter number or section number, etc. This is controlled by options in the setup file; for example, setting `@ChapterNumInDisplays` to `Yes` ensures that numbered displays will be numbered afresh at the beginning of each chapter, and that the number will include a chapter number. There is also a `@DisplayNumStyle` option which controls the style of displays; the default value, `(num)`, encloses the number in parentheses as usual for equations.

Every display symbol has an abbreviated form consisting of `@` followed by its capital letters only. For example, `@BeginAlignedDisplays` may be abbreviated to `@BAD`, and the display that has everything to `@RCAND`. Owing to an unfortunate clash between the initial letters of 'raw' and 'right', `@RightDisplay` and the other right displays have no abbreviations.

7.5. Defining new mathematical symbols

Whenever you type a particular piece of mathematics repeatedly, you can save time by using definitions. Definitions are the subject of Section 2.13, so here we will just give a few examples of their use in formatting mathematics.

Suppose for example that $p_i \log_2 p_i$ occurs frequently in your document. Then

```
def epi { p sub i ' log sub 2 ' p sub i }
```

makes the symbol `epi` stand for the object between the braces:

```
sum from { i=1 } to { n } ' epi
```

$$\sum_{i=1}^n p_i \log_2 p_i$$

Parameters are very useful when parts of the symbol vary:

```
def ep right x
{
  p sub x ' log sub 2 ' p sub x
}
```

The parameter x will be replaced by the object just to the right of ep:

$$\begin{array}{l} \text{sum from } \{ i=1 \} \text{ to } \{ k \} \text{ ' ep } i + \\ \text{sum from } \{ j=k+1 \} \text{ to } \{ n \} \text{ ep } j \end{array} \quad \sum_{i=1}^k p_i \log_2 p_i + \sum_{j=k+1}^n p_j \log_2 p_j$$

The precedence of the symbols you define will be 100 by default. To make the symbols of @Math available within such definitions, each must be preceded by import @Math. As explained in Section 2.13, the definitions go into a file called mydefs, which might look like this:

```
import @Math
def epi { p sub i ' log sub 2 ' p sub i }

import @Math
def ep right x { p sub x ' log sub 2 ' p sub x }
```

Use of epi and ep outside @Math will cause an error.

7.6. Summary

This section is a complete list of the symbols provided by @Math. We divide them into *helper*, *ordinary*, *variable-building*, *large operator*, *unary operator*, *binary operator*, *relation*, and *punctuation* symbols. The precedences of these symbols, where relevant, are as follows:

<i>Symbol type</i>	<i>Precedence</i>	<i>Symbols</i>
Helper	100	big small vctr @SuperScriptStyle etc.
Variable-building	84	dot dotdot hat tilde vec dyad overbar underbar
Variable-building	82	sub on ton
Variable-building	80	sup supp
Unary operator	70	sqrt root zroot matrix etc.
Binary operator	64	times *
Binary operator	62	div frac over
Binary operator	60	bin + - and all other binary operator symbols
Relation	50	rel and all other relation symbols
Punctuation	40	punct ; , col
Helper	26	non
Helper	24	above below wideabove widebelow
Helper	22	col lcol ccol rcol mcol
Helper	20	row axisrow

Results are shown in display style in this section; the other styles give more compressed results.

7.6.1. Helper symbols

The full list of helper symbols is

'	Thin space, as after punctuation symbols
"	Medium space, as around binary operator symbols
“	Thick space, as around relation symbols
big x	Make x larger
small x	Make x smaller
vctr x	Centre x vertically
@SuperScriptStyle x	Set x in the style of a superscript
@SubScriptStyle x	Set x in the style of a subscript
@NumeratorStyle x	Set x in the style of a numerator
@DenominatorStyle x	Set x in the style of a denominator
@SquareRootStyle x	Set x in the style of a square root
above below wideabove widebelow	Vertical stacking (see below)
col lcol ccol rcol mcol row axisrow	Used only within matrices (Section 7.3)
non x	Remove spaces from x (see below)

where x is arbitrary as usual. The above symbol prints the preceding object above the following object, while the below symbol prints it below:

$$\{ a \text{ above } f \} + \{ z \text{ below } b \} \qquad a + \frac{b}{z}$$

Here is a larger example:

$$\text{sum from } \left\{ \left\{ 1 \leq i \leq p \right\} \text{ above } \left\{ 1 \leq j \leq q \right\} \text{ above } \left\{ 1 \leq k \leq r \right\} \right\} \sum_{\substack{1 \leq i \leq p \\ 1 \leq j \leq q \\ 1 \leq k \leq r}} a_{ij} b_{jk} c_{ki}$$

$$\{ a \text{ sub } ij \ b \text{ sub } jk \ c \text{ sub } ki \}$$

The wideabove and widebelow symbols are like above and below except that they horizontally scale the right parameter to the width of the left:

$$\{a, \dots, z\} \text{ wideabove} \qquad \overbrace{a, \dots, z}$$

$$\{90d \ @Rotate blbrace\}$$

$$\{a, \dots, z\} \text{ widebelow minus} \qquad \overline{a, \dots, z}$$

The non symbol prints the following object without the horizontal spacing it would usually contain. It has low precedence so that, in examples like

The '@M { non <= }' operation is reflexive and transitive.

which produces

The '<=' operation is reflexive and transitive.

it is easy to use the familiar symbolic names for relations and operators without getting the usual surrounding spaces, saving the trouble of looking up the names of the characters.

7.6.2. Ordinary symbols

Ordinary symbols are the simplest symbols. They do not take objects to their left or right, and they always look the same except for the usual change of size in certain contexts (superscripts, subscripts, etc.). There are hundreds of these symbols, so they are presented here in groups.

The first group consists of all the symbols from the Adobe Symbol font; these are as for the @Sym symbol of Section 1.4, but within @Math you don't type @Sym:

space		exclam	!	universal	\forall
numbersign	#	existential	\exists	percent	%
ampersand	&	suchthat	\ni	parenleft	(
parenright)	asteriskmath	*	plus	+
comma	,	minus	-	period	.
slash	/	zero	0	one	1
two	2	three	3	four	4
five	5	six	6	seven	7
eight	8	nine	9	colon	:
semicolon	;	less	<	equal	=
greater	>	question	?	congruent	\equiv
Alpha	A	Beta	B	Chi	X
Delta	Δ	Epsilon	E	Phi	Φ
Gamma	Γ	Eta	H	Iota	I
thetaone	ϑ	Kappa	K	Lambda	Λ
Mu	M	Nu	N	Omicron	O
Pi	Π	Theta	Θ	Rho	P
Sigma	Σ	Tau	T	Upsilon	Y
sigmaone	ς	Omega	Ω	Xi	Ξ
Psi	Ψ	Zeta	Z	bracketleft	[
therefore	\therefore	bracketright]	perpendicular	\perp
underscore	_	radicalex	$\sqrt{\quad}$	alpha	α
beta	β	chi	χ	delta	δ
epsilon	ϵ	phi	ϕ	gamma	γ
eta	η	iota	ι	phione	φ
kappa	κ	lambda	λ	mu	μ
nu	ν	omicron	\omicron	pi	π
theta	θ	rho	ρ	sigma	σ
tau	τ	upsilon	υ	omegaone	ω
omega	ω	xi	ξ	psi	ψ
zeta	ζ	braceleft	{	bar	
braceright	}	similar	\sim	Upsilonone	Υ
minute	'	lessequal	\leq	fraction	/
infinity	∞	florin	f	club	\clubsuit
diamond	\blacklozenge	heart	\heartsuit	spade	\spadesuit
arrowboth	\leftrightarrow	arrowleft	\leftarrow	arrowup	\uparrow
arrowright	\rightarrow	arrowdown	\downarrow	degree	$^\circ$
plusminus	\pm	second	"	greaterequal	\geq

multiply	\times	proportional	\propto	partialdiff	∂
bullet	\bullet	divide	\div	notequal	\neq
equivalence	\equiv	aproxequal	\approx	ellipsis	\dots
arrowvertex		arrowhorizex	—	carriagereturn	\downarrow
aleph	\aleph	lfraktur	\mathfrak{S}	Rfraktur	\mathfrak{R}
weierstrass	\wp	circlemultiply	\otimes	circleplus	\oplus
emptyset	\emptyset	intersection	\cap	union	\cup
propersuperset	\supset	reflexsuperset	\supseteq	notsubset	$\not\subset$
propersubset	\subset	reflexsubset	\subseteq	element	\in
notelement	\notin	angle	\sphericalangle	gradient	∇
registerserif	$\text{\textcircled{R}}$	copyrightserif	$\text{\textcircled{C}}$	trademarkserif	TM
product	\prod	radical	$\sqrt{\quad}$	dotmath	\cdot
logicalnot	\neg	logicaland	\wedge	logicalor	\vee
arrowdblboth	\Leftrightarrow	arrowdblleft	\Leftarrow	arrowdblup	\Uparrow
arrowdblright	\Rightarrow	arrowdblright	\Downarrow	lozenge	\diamond
anglerleft	\langle	registersans	$\text{\textcircled{R}}$	copyrightsans	$\text{\textcircled{C}}$
trademarksans	TM	summation	Σ	parenlefttp	\lparen
parenleftex		parenleftbt	\lrcorner	bracketlefttp	\lbrack
bracketleftex		bracketleftbt	\lfloor	bracelefttp	\lceil
braceleftmid	$\{$	braceleftbt	\lfloor	braceex	
anglerright	\rangle	integral	\int	integraltp	\int
integralex		integralbt	\int	parenrighttp	\rparen
parenrightex		parenrightbt	\rfloor	bracketrighttp	\rbrack
bracketrightex		bracketrightbt	\rfloor	bracerighttp	\rceil
bracerightmid	$\}$	bracerightbt	\rfloor		

The symbols that produce the Symbol font characters theta1, sigma1, phi1, omega1, and Upsilon1 are called thetaone, sigmaone, phione, omegaone, and Upsilonone, since Lout symbol names cannot contain both letters and digits. The second group of ordinary symbols produces arrows:

leftarrow	\leftarrow	longleftarrow	\longleftarrow	dblleftarrow	\Lleftarrow
dbllongleftarrow	\Lleftarrow	rightarrow	\rightarrow	longrightarrow	\longrightarrow
dblrightarrow	\Rightarrow	dblrightarrow	\Longrightarrow	leftrightarrow	\leftrightarrow
longleftrightarrow	\longleftrightarrow	dblleftrightarrow	\Lleftrightarrow	dbllongleftrightarrow	\Llongleftrightarrow
mapsto	\mapsto	longmapsto	\longmapsto	hookleftarrow	\hookleftarrow
hookrightarrow	\hookrightarrow	leadsto	\leadsto	leftharpoonup	\leftharpoonup
rightharpoonup	\rightharpoonup	leftharpoondown	\leftharpoondown	rightharpoondown	\rightharpoondown
rightleftharpoons	\rightleftharpoons	uparrow	\uparrow	dbluparrow	\Uparrow
downarrow	\downarrow	dbldownarrow	\Downarrow	updownarrow	\Updownarrow
dblupdownarrow	\Updownarrow	nearrow	\nearrow	searrow	\searrow
swarrow	\swarrow	nwarrow	\nwarrow		

The members of the third group of ordinary symbols stand for themselves, but in Roman font rather than the Italic which is the default in mathematics:

arccos	arccos	arcsin	arcsin	arctan	arctan
arg	arg	cos	cos	cosh	cosh
cot	cot	coth	coth	csc	csc
deg	deg	det	det	dim	dim
exp	exp	gcd	gcd	hom	hom
inf	inf	ker	ker	lg	lg
lim	lim	liminf	lim inf	limsup	lim sup
ln	ln	log	log	max	max
min	min	Pr	Pr	sec	sec
sin	sin	sinh	sinh	supr	sup
tan	tan	tanh	tanh	mod	mod
0	0	1	1	2	2
3	3	4	4	5	5
6	6	7	7	8	8
9	9	!	!	?	?
%	%	(())
[[]]		

The fourth group make good values for the atleft and atright options of matrix:

lpar	(rpar)	lbrack	[rbrack]
lbrace	{	rbrace	}	lfloor	⌊	rfloor	⌋
lceil	⌈	rceil	⌋	langle	⟨	rangle	⟩
blpar	(brpar)	blbrack	[brbrack]
blbrace	{	brbrace	}	blfloor	⌊	brfloor	⌋
blceil	⌈	brceil	⌋	blangle	⟨	brangle	⟩

The last group is miscellaneous:

hbar	\hbar	Re	\Re	Im	\Im
partial	∂	infty	∞	prime	'
nabla	∇	surd	$\sqrt{\quad}$	top	\top
bot	\perp	dbar	$\bar{\quad}$	triangle	\triangle
backslash	\backslash	forall	\forall	exists	\exists
neg	\neg	circle	\bigcirc	filledcircle	\bullet
square	\square	ldots	\dots	cdots	\cdots
vdots	\vdots	ddots	\ddots	del	∇
grad	∇	...	\dots	''''	\dots
,	,	"	"	'''	\dots
'''	\dots	empty	\emptyset	triangleup	\triangle
triangledown	∇	half	$\frac{1}{2}$	third	$\frac{1}{3}$

7.6.3. Variable-building symbols

Under this category are symbols that are mainly used to build variables. However, as usual in Lout, the objects they link together may in fact be arbitrary. First we have symbols that place a mark over or under an object:

$$\begin{array}{lll}
 \text{x dot} & \dot{x} & \text{x dotdot} & \ddot{x} & \text{x hat} & \hat{x} \\
 \text{x tilde} & \tilde{x} & \text{x vec} & \vec{x} & \text{x dyad} & \leftrightarrow \\
 \{\text{x + y}\} \text{ overbar} & \overline{x+y} & \{\text{x + y}\} \text{ underbar} & \underline{x+y} & &
 \end{array}$$

These marks are centred, with a small skew to allow for italic slant, except the last two which are extended to the width of the object.

The remaining variable-building symbols produce superscripts and subscripts: so the results are shown in both display and text style:

$$\begin{array}{lll}
 \text{x sup y} & x^y & \text{x sub y} & x_y & \text{W tsub y} & W_y \\
 \text{x supp y on z} & x_z^y & \text{W supp y ton z} & W_z^y & &
 \end{array}$$

The supp and on (or ton) symbols must be used together as shown; tsub and ton are exactly like sub and on except that the subscript is tucked in.

7.6.4. Large operator symbols

Large operator symbols have from and to options which work as described for the sum symbol in Section 7.2. Here they all are, with their results in both display style and text style:

$$\begin{array}{lll}
 \text{sum from } \{a\} \text{ to } \{b\} \text{ x} & \sum_a^b x & \sum_a^b x \\
 \text{coprod from } \{a\} \text{ to } \{b\} \text{ x} & \coprod_a^b x & \coprod_a^b x \\
 \text{bcup from } \{a\} \text{ to } \{b\} \text{ x} & \bigcup_a^b x & \bigcup_a^b x \\
 \text{bwedge from } \{a\} \text{ to } \{b\} \text{ x} & \bigwedge_a^b x & \bigwedge_a^b x \\
 \text{botimes from } \{a\} \text{ to } \{b\} \text{ x} & \bigotimes_a^b x & \bigotimes_a^b x \\
 \text{boplus from } \{a\} \text{ to } \{b\} \text{ x} & \bigoplus_a^b x & \bigoplus_a^b x \\
 \text{buplus from } \{a\} \text{ to } \{b\} \text{ x} & \biguplus_a^b x & \biguplus_a^b x \\
 \text{oint from } \{a\} \text{ to } \{b\} \text{ x} & \oint_a^b x & \oint_a^b x \\
 \text{prod from } \{a\} \text{ to } \{b\} \text{ x} & \prod_a^b x & \prod_a^b x \\
 \text{bcap from } \{a\} \text{ to } \{b\} \text{ x} & \bigcap_a^b x & \bigcap_a^b x \\
 \text{bvee from } \{a\} \text{ to } \{b\} \text{ x} & \bigvee_a^b x & \bigvee_a^b x \\
 \text{bodot from } \{a\} \text{ to } \{b\} \text{ x} & \bigodot_a^b x & \bigodot_a^b x \\
 \text{int from } \{a\} \text{ to } \{b\} \text{ x} & \int_a^b x & \int_a^b x
 \end{array}$$

All these symbols also have a limits option; when set to yes it causes the limits to be shown above and below the symbol, when no it causes them to be shown as superscripts and subscripts, and when omitted it defaults to yes in display style and no otherwise, except for integrals, where the default is uniformly no as required by mathematical convention.

The `largeop` symbol causes an arbitrary object to be treated options which work as described for the `sum` symbol as a large operator:

`largeop symbol { diamond } from { a } to { b } x` $\overset{b}{\underset{a}{\blacklozenge}}x$

In addition to `limits`, `from`, and `to` options, `largeop` has a `symbol` option holding the object to be made into a large operator. In display style, this object is enlarged using the `big` helper function.

7.6.5. Unary operator symbols

This category mainly contains symbols that take one object on the right and transform it.

`sqrt {x over y}` $\sqrt{\frac{x}{y}}$

`3 root {x over y}` $\sqrt[3]{\frac{x}{y}}$

`matrix atleft { (} atright {) } { x }` (x)

As usual, any object may appear to the left of `root`. The `matrix` symbol produces matrices, as explained in detail in Section 7.3. Its following object must be enclosed in braces.

There are symbols which produce ‘matrices’ with commonly needed `atleft` and `atright` options already set for you. Here are these symbols, on the left, with the equivalent `matrix` symbol and, on the right, the result produced:

<code>pmatrix { M }</code>	<code>matrix atleft { (} atright {) } { M }</code>	(M)
<code>bmatrix { M }</code>	<code>matrix atleft { blbrack } atright { brbrack } { M }</code>	$[M]$
<code>brmatrix { M }</code>	<code>matrix atleft { blbrace } atright { brbrace } { M }</code>	$\{M\}$
<code>fmatrix { M }</code>	<code>matrix atleft { blfloor } atright { brfloor } { M }</code>	$\lfloor M \rfloor$
<code>cmatrix { M }</code>	<code>matrix atleft { blceil } atright { brceil } { M }</code>	$\lceil M \rceil$
<code>amatrix { M }</code>	<code>matrix atleft { blangle } atright { brangle } { M }</code>	$\langle M \rangle$

These are very useful for getting large scaled delimiters around things that aren’t necessarily matrices at all.

7.6.6. Binary operator symbols

The symbols in this category take an object on the left and on the right. The first two produce built-up fractions:

`x over y` $\frac{x}{y}$ `x frac y` $x\frac{y}{y}$

The remaining binary operator symbols print the objects to the left and right separated by the operator with a medium-width space on each side. Most have precedence 80, but a few (those

representing multiplication and division operations) have higher precedence in accordance with mathematical convention. Here is the full list of these operators:

<code>x + y</code>	$x + y$	<code>x - y</code>	$x - y$	<code>x +- y</code>	$x \pm y$
<code>x -+ y</code>	$x \mp y$	<code>x setminus y</code>	$x \setminus y$	<code>x cdot y</code>	$x \cdot y$
<code>x times y</code>	$x \times y$	<code>x * y</code>	$x * y$	<code>x circ y</code>	$x \circ y$
<code>x div y</code>	$x \div y$	<code>x cap y</code>	$x \cap y$	<code>x cup y</code>	$x \cup y$
<code>x uplus y</code>	$x \oplus y$	<code>x sqcap y</code>	$x \sqcap y$	<code>x sqcup y</code>	$x \sqcup y$
<code>x triangleleft y</code>	$x \triangleleft y$	<code>x triangleright y</code>	$x \triangleright y$	<code>x wr y</code>	$x \wr y$
<code>x bigcirc y</code>	$x \bigcirc y$	<code>x bigtriangleup y</code>	$x \bigtriangleup y$	<code>x bigtriangledown y</code>	$x \bigtriangledown y$
<code>x vee y</code>	$x \vee y$	<code>x wedge y</code>	$x \wedge y$	<code>x oplus y</code>	$x \oplus y$
<code>x ominus y</code>	$x \ominus y$	<code>x otimes y</code>	$x \otimes y$	<code>x oslash y</code>	$x \oslash y$
<code>x odot y</code>	$x \odot y$	<code>x dagger y</code>	$x \dagger y$	<code>x daggerdbl y</code>	$x \ddagger y$
<code>x amalg y</code>	$x \amalg y$				

The `bin` symbol causes an arbitrary object to be treated as a binary operator:

`x bin op { diamond } y` $x \blacklozenge y$

The `op` option following `bin` contains the object to be treated as a binary operator; its two parameters precede and follow `bin` as usual.

7.6.7. Relation symbols

These symbols represent relations. They take an object on the left and on the right, and print them separated by the relation symbol, with a slightly wider space on each side than is used for binary operators. They have lower precedence than binary operators, in accordance with mathematical convention. Here is the full list of these relations:

<code>x < y</code>	$x < y$	<code>x > y</code>	$x > y$	<code>x = y</code>	$x = y$
<code>x <= y</code>	$x \leq y$	<code>x prec y</code>	$x \prec y$	<code>x preceq y</code>	$x \preceq y$
<code>x << y</code>	$x \ll y$	<code>x subset y</code>	$x \subset y$	<code>x subseteq y</code>	$x \subseteq y$
<code>x sqsubseteq y</code>	$x \sqsubseteq y$	<code>x in y</code>	$x \in y$	<code>x vdash y</code>	$x \vdash y$
<code>x smile y</code>	$x \smile y$	<code>x frown y</code>	$x \frown y$	<code>x >= y</code>	$x \geq y$
<code>x succ y</code>	$x \succ y$	<code>x succeq y</code>	$x \succeq y$	<code>x >> y</code>	$x \gg y$
<code>x supset y</code>	$x \supset y$	<code>x supseteq y</code>	$x \supseteq y$	<code>x sqsupseteq y</code>	$x \sqsupseteq y$
<code>x ni y</code>	$x \ni y$	<code>x dashv y</code>	$x \dashv y$	<code>x mid y</code>	$x \mid y$
<code>x parallel y</code>	$x \parallel y$	<code>x == y</code>	$x \equiv y$	<code>x ~ y</code>	$x \sim y$
<code>x -- y</code>	$x \approx y$	<code>x asymp y</code>	$x \asymp y$	<code>x ~~ y</code>	$x \approx y$
<code>x =~ y</code>	$x \cong y$	<code>x bowtie y</code>	$x \bowtie y$	<code>x propto y</code>	$x \propto y$
<code>x models y</code>	$x \models y$	<code>x trieq y</code>	$x \triangleq y$	<code>x doteq y</code>	$x \doteq y$
<code>x perp y</code>	$x \perp y$	<code>x notsub y</code>	$x \not\subset y$	<code>x notin y</code>	$x \notin y$
<code>x != y</code>	$x \neq y$	<code>x <-> y</code>	$x \leftrightarrow y$	<code>x <- y</code>	$x \leftarrow y$
<code>x --> y</code>	$x \rightarrow y$	<code>x up y</code>	$x \uparrow y$	<code>x down y</code>	$x \downarrow y$
<code>x <=> y</code>	$x \Leftrightarrow y$	<code>x <== y</code>	$x \Leftarrow y$	<code>x ==> y</code>	$x \Rightarrow y$
<code>x dblup y</code>	$x \Uparrow y$	<code>x dbldown y</code>	$x \Downarrow y$	<code>x : y</code>	$x : y$
<code>x :: y</code>	$x :: y$	<code>x := y</code>	$x := y$		

All of these symbols have a `neg` option which, when set to `yes`, causes a slash to overstrike the relation symbol:

$$x ==> \text{neg } \{ \text{yes} \} y \qquad x \not\Rightarrow y$$

The slash is horizontally centred over the relation symbol, which is not always best.

The `rel` symbol causes an arbitrary object to be treated as a relation:

$$x \text{ rel op } \{ \text{diamond} \} y \qquad x \blacklozenge y$$

The `op` option following `rel` contains the object to be treated as a relation; `rel` also has the `neg` option, plus the left and right parameters as usual.

7.6.8. Punctuation symbols

These symbols represent punctuation. They take an object on the left and on the right, and print them separated by the punctuation symbol, with no space to the left and a thin space to the right. Here is the full list of these symbols:

$$x ; y \quad x;y \qquad x , y \quad x,y \qquad x \text{ col } y \quad x:y$$

The `punct` symbol causes an arbitrary object to be treated as punctuation:

$$x \text{ punct symbol } \{ \text{diamond} \} y \qquad x \blacklozenge y$$

The `symbol` option following `punct` contains the object to be treated as punctuation; its two parameters precede and follow `punct` as usual.

Chapter 8. Basic Graphics

This chapter introduces some basic graphics symbols for colour, texture, rotation, scaling, and included illustrations. These are all from the standard BasicLayout package, so no `@SysInclude` line is needed to get them beyond the usual `@SysInclude { doc }` or whatever.

8.1. Colour

Colour is obtained in much the same way that fonts and language changes are, using the `@Colour` (or equivalently `@Color`) symbol:

```
grey @Colour { Hello, world }
```

produces

Hello, world

The `@Colour` symbol will accept any of the following colours:

	darkred		red		lightred
	darkgreen		green		lightgreen
	darkblue		blue		lightblue
	darkcyan		cyan		lightcyan
	darkmagenta		magenta		lightmagenta
	darkyellow		yellow		lightyellow
	darkgrey		grey		lightgrey
	darkgray		gray		lightgray
	black		white		

Monochrome output devices will render them as shades of grey. Colouring something white makes it invisible (unless printed on a coloured background), which is sometimes useful. See Appendix C to get many more colour names, using the `xrgb` include file and its `@Xrgb` symbol.

In addition to the list of colours given above, there is a special `nochange` colour which produces whatever colour you already happen to be using; you can also use an empty object to ask for this. And you can get lots more colours by specifying them using numbers, like this:

```
{ rgb 0.5 0.5 1.0 } @Colour { Hello, world }
```

which means use red at intensity 0.5, green at intensity 0.5, and blue at intensity 1.0, producing

Hello, world

In the strange world of colour coordinates, in which 0 is dark and 1 is light, this is a light blue. You can also use the CMYK system:

```
{ cmyk 0.5 0.5 1.0 1.0 } @Colour { Hello, world }
```

produces

Hello, world

Wherever in this document it says that that you can use any colour from this section, it means any of the names above, or `nochange`, or an object beginning with `rgb` or `cmyk` as shown.

Whether the colours produced by `@Colour` actually correspond with the names depends on the output device; the same nominal colour can look quite different on screen and on paper.

8.2. Textures

The `@Texture` symbol works in the same kind of way as `@Font` and `@Colour` do. It causes the object to its right to be printed in a texture specified by the object to its left:

```
striped @Texture 40p @Font ABC
```

produces¹



The object to the right of `@Texture` may be arbitrary as usual.

Only a handful of textures are offered by the `@Texture` symbol; but, as some compensation, there are options which allow any texture to be scaled, printed at any angle, and shifted:

```
striped @Texture
  scale { 2 }
  angle { 45d }
  hshift { 1p }
  vshift { 3p }
40p @Font ABC
```

produces



with the texture scaled by a factor of 2, printed at an angle of 45 degrees, and shifted one point horizontally and three points vertically. The `scale` option causes equal scaling in the horizontal and vertical directions; there is also `hscale` which scales horizontally only, and `vscale` which scales vertically only. As you would expect, the default values of these options are 1 for the

¹If you can't see the result here, or if you can see it but without texture, then the fault is probably in your PostScript viewer. The PostScript viewer used by the author (a 1997 version of `gv`) shows a blank space here and throughout this section wherever a texture is supposed to appear, but when printed on his printer the textures appear correctly. Some viewers may fail altogether when given a PostScript file with textures. In that case, run your document again using `lout -t` instead of `lout`. This will cause Lout to ignore all textures and print everything in solid colour.

scaling options, 0d for angle, and 0p for hshift and vshift.

Here is the list of all textures offered by the @Texture symbol, with the options specific to each kind of texture, their default values, and sample default output. Remember, all textures take the angle, scale, hscale, vscale, hshift, and vshift options as well.



solid @Texture

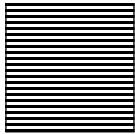

striped @Texture

width { 1p }

The width of each stripe

gap { 1p }

The width of each gap between stripes

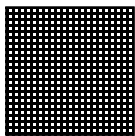

grid @Texture

width { 1p }

The width of each stripe

gap { 1p }

The width of each gap between stripes

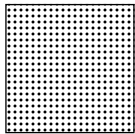

dotted @Texture

radius { 0.5p }

The radius of each dot (filled circle)

gap { 2p }

The gap between the centres of adjacent dots

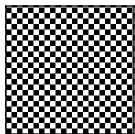

chessboard @Texture

width { 2p }

The width of each square

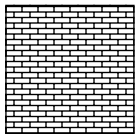

brickwork @Texture

width { 6p }

The width of each brick

height { 2p }

The height of each brick

linewidth { 0.5p }

The width of the brickwork lines

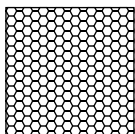

honeycomb @Texture

radius { 2p }

The radius of each hexagon

linewidth { 0.5p }

The width of the lines

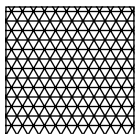

triangular @Texture

radius { 4p }

The side length of each triangle

linewidth { 0.5p }

The width of the lines

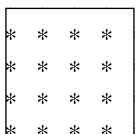

string @Texture

width { 12p }

The width at which the string repeats

height { 12p }

The height at which the string repeats

font { Times-Roman }

The font used to display the string (see below)

size { 10p }

The font size used to display the string

value { "*" }

The characters to be displayed

This last example seems like a good one for experimenting with the `hshift` and `vshift` options, so here goes:

*	*	*	*
*	*	*	*
*	*	*	*
*	*	*	*

```
string @Texture
  hshift { 4p }
  vshift { 4p }
```

You have to find the right amount of shift by experiment, especially when combined with rotation and scaling. We recommend sticking to the `p` (points), `m` (ems), `c` (centimetres), and `i` (inches) units of measurement when giving length options to `@Texture` symbols.

Care is needed when using the `font` and `value` options of `string @Texture`, since these options are passed straight through to the PostScript output without checking. The `font` option takes a PostScript name for a font, not a Lout name. Typical PostScript font names, virtually certain to work, are Times-Roman and Helvetica. Since Lout takes no special steps to make sure that the font you ask for is available, you should restrict your font choices to fonts known to be in use elsewhere on the same page, or known to be always loaded in your viewing device. The `value` option must be a sequence of characters from the nominated font. Although the value does not have to be quoted as shown, we recommend it as a reminder of how limited the choices are here. Also, spaces in your value will work better between quotes, and to make parentheses `(` and `)` come out correctly they must be enclosed in quotes and preceded by a backslash character, which you get as usual by writing *two* backslash characters. For example, `"\"` will produce one left parenthesis.

Notice that `solid @Texture` produces solid colour, or in other words no texture:

```
striped @Texture angle { 45d }
@Box linewidth { 2p } solid @Texture 50p @Font WARNING!
```

produces

As shown, `solid @Texture` is useful for switching back to normal printing within a textured region. In this example, without it the letters would have been striped as well.

Expert users can also make the object to the left of `@Texture` be anything that is acceptable to the left of the expert's symbol `@SetText`, allowing people who want to do some serious work in PostScript to get arbitrary textures. Consult the Expert's Guide for more about this.

8.3. Boxes and rules

The `@Box` symbol causes the following object to be enclosed in a box:

```
@QuotedDisplay @Box {
@CentredDisplay @Heading Cheating
The Department uses assignments ... of that student alone.
}
```

The result of this is

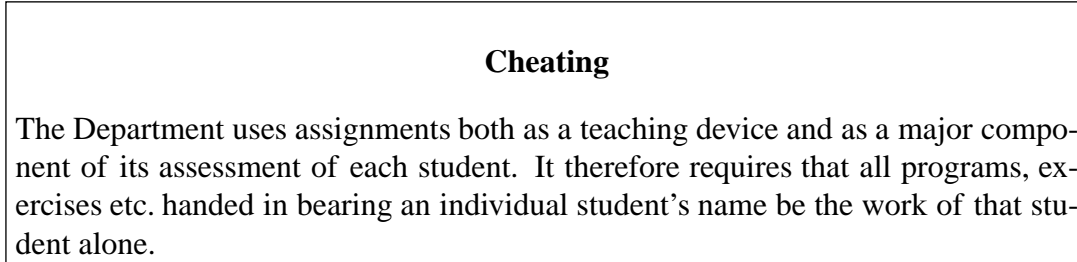

showing that a box may enclose an arbitrarily complicated object.

The @Box symbol has a margin option which determines the margin between the box and what it encloses. For example,

```
@Box
margin { 0.1c }
{ }
```

requests a box with a 0.1 centimetre margin enclosing an empty object, so the result is a square whose width and height are 0.2 centimetres:

□

If the margin option is omitted, it is assigned the default value 0.3f, which means 0.3 times the current font size. It is very useful to tie the margin to the font size in this way, because large headings (in overhead transparencies, say) need large margins.

There is a linewidth option which determines the width (thickness) of the line drawn around the boundary of the box:

```
@Box
linewidth { 0.1c }
{ Hello world }
```

produces

Lout does not take the line width into account when working out how large everything is: as far as Lout is concerned, the line always has width zero. If you draw really thick lines you might need a larger margin and more space near the box. The default value of linewidth is empty, which means to use whatever width the PostScript interpreter in your output device thinks is a good default value. The special value none for linewidth ensures that no line is drawn around the box at all.

There is also a paint option which paints a background of the nominated colour:

```
@Box paint { grey } WARNING!
```

has result



This is quite different from grey @Colour @Box WARNING!, which produces



The paint option may be given any colour from the list in Section 8.1; its default value is none, which is a special value (not a colour) which means no painting. White paint comes into its own inside painted boxes:

```
@Box paint { nochange } white @Colour { Hello world }
```

produces a box painted in whatever colour we happen to be using at the moment, with white text inside:



This works because the box is painted before the object it encloses is drawn on the page.

Wherever there is a paint option in Lout for painting the background of something, there is always an accompanying texture option for applying that paint with the textures described in Section 8.2. For example,

```
@Box paint { black } texture { brickwork } 50p @Font WARNING!
```

produces¹

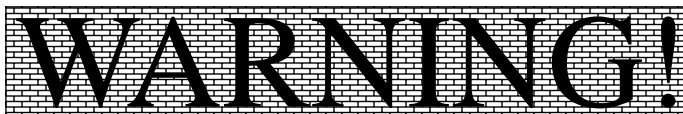

If paint is absent or none then texture will have no effect. Since textures are naturally lighter than solid colour, you will usually need darker paint when using textures than when not.

To set options on a texture within a texture option, you can write

```
texture { striped @Texture angle { 45d } scale { 2 } }
```

mimicking the @Texture symbol from Section 8.2, but without any following object. However, it's clunky to have to type both texture and @Texture, so by special arrangement you can omit the @Texture symbol within the texture option:

```
texture { striped angle { 45d } scale { 2 } }
```

¹As explained in Section 8.2, if you can't see any textures the problem is probably with your PostScript viewer.

The value of the texture option may also be an expert's texture as required by `@SetText`. Incidentally, there is no significance in our laying out all the options along one line. As always in Lout, the end of a line and a space mean the same. We've done it this way because we think it's the clearest way to lay out the texture option.

Let's just summarize the painting and texturing possibilities for boxes. A box has three components: its outline, its background, and its content (what appears inside). You can actually set the colour and texture of all three components independently of each other, with a little trouble:

```
black @Colour striped @Texture angle { 45d }
@Box
  paint { lightgrey }
  linewidth { 2p }
  texture { striped angle { 90d } }
darkgrey @Colour striped @Texture scale { 2 } 50p @Font ABC
```

produces

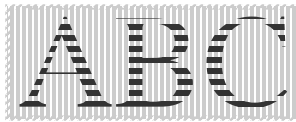

The outline colour and texture are the colour and texture from outside the box; the background colour and texture are always determined by the `paint` and `texture` options; and the colour and texture of the contents are inherited from outside the box, but can be changed as shown if desired. Notice what happens when two textures overstrike: the lower one shows through the unpainted parts of the upper one.

There are `@CurveBox` and `@ShadowBox` symbols that produce other kinds of boxes:

A curve box

A shadow box

These also have `margin`, `linewidth`, `paint`, and `texture` options, and `@ShadowBox` has a `shadow` option which determines the thickness of the shadow (its default value is 0.2f). There is no option to change the colour of the shadow, but it is quite easy to combine two boxes to get that effect:

```
lightgrey @Colour @ShadowBox margin { 0c } black @Colour @Box
{
  A shadow box
}
```

produces

A shadow box

in which the shadow, and only the shadow, is coloured light grey.

Boxes are quite at home inside paragraphs, as `a box`, `a curve box`, and `a shadow box` show. Simply proceed as usual:

... paragraphs, as @Box { a box }, @CurveBox { a curve box }, ...

Boxes within paragraphs are never broken across two lines.

There are two symbols for producing horizontal rules. @FullWidthRule produces a rule which occupies the full page (or column) width:

More precisely, the rule occupies as much horizontal space as it legally can. @FullWidthRule produces an object in the usual way, so you will need paragraph or display symbols to separate it from preceding and following things.

A variant called @LocalWidthRule is more timid about zooming across the whole page:

```
@OddPageTop { { My lovely document @LP @LocalWidthRule } @Right @PageNum }
```

will draw a rule under just the three words. Of course, underlining using the @Underline symbol might be a better way to do this.

These two rule symbols are handled behind the scenes like the outlines of boxes. Both symbols have a linewidth option which works like the one for boxes described above. In particular, Lout leaves zero space for the line, no matter how wide you make it. And to change the colour or texture of a rule, it must be enclosed in @Colour and @Texture symbols:

```
chessboard @Texture scale { 2 } @FullWidthRule linewidth { 8p }
```

produces



Notice how we have made sure that the rule is wide enough to accommodate two rows of the chessboard texture. The author's printer places a thin row of solid colour along the top of this pattern. Logically it should not be there; it can be got rid of by reducing the line width:

```
chessboard @Texture scale { 2 } @FullWidthRule linewidth { 7.5p }
```

produces



We can only guess that the problem might be roundoff error.

8.4. Outlined words

The @Outline symbol causes all the words in the following object (which may be arbitrary as usual) to be printed in outline. For example,

```
@Outline @Box 24p @Font HELP
```

produces



There is no way to control the thickness of the outline, and @Outline has no effect in PDF output. On the other hand, it works with any font likely to be used in practice.

8.5. Rotation

The @Rotate symbol rotates the following object by any positive or negative angle, measured in degrees:

```
45d @Rotate @Box WARNING!
```

has result



As usual, the object to be rotated may be arbitrary. However, it is difficult for Lout to choose appropriate column widths for paragraphs inside rotated objects, so if a rotated object contains paragraphs that should be broken it is best to define the object's width explicitly, using the @Wide symbol from Section 8.10:

```
-90d @Rotate 4.5c @Wide {
  Papal initiatives and influence from the crowning of
  Charlemagne to the First Crusade
}
```

The result here is

Papal initiatives and influence from the crowning of Charlemagne to the First Crusade

The @Wide symbol fixes the width of the following object, in this example to the length 4.5 centimetres, which is all Lout needs to decide the column widths of any paragraphs within it.

8.6. Scaling

The @Scale symbol performs a geometrical scaling of the following object:

```
0.5 @Scale @Box WARNING!
```

produces

WARNING!

A scale factor of 0.5 means half the original size, 2.0 means double size, and so on. No unit of measurement appears in the scale factor, because it makes no sense to have one. As usual, the object to be scaled may be arbitrary.

It is also possible to supply two scale factors, in which case the first is applied horizontally and the second vertically:

```
{0.5 2.0} @Scale @Box WARNING!
```

has result

WARNING!

Practical uses for this kind of scaling are rare.

If an empty object is given instead of a scale factor, like this:

```
{ } @Scale @Box WARNING!
```

the `@Scale` symbol will choose the largest scale factor that does not overrun the available horizontal space. It is often possible to omit the `{ }`, since Lout inserts an empty object automatically whenever an object is clearly missing (see Section 1.2). For example,

```
@QuotedDisplay @Scale @Box WARNING!
```

produces

WARNING!

`@QuotedDisplay` and `@LeftDisplay` go well with this form of `@Scale`. However, some care is needed because Lout foolishly takes no account of the available *vertical* space when choosing the scale factor. The chosen scale factor could enlarge the vertical size so much that the object no longer fits on the page, with disastrous results.

By using the `@Wide` symbol from Section 8.10 to restrict the available horizontal space, this form of scaling can also be used to scale to a nominated width. For example,

```
5c @Wide @Scale @Box WARNING!
```

produces

WARNING!

which is 5 centimetres wide.

The @Scale symbol will scale either up or down, whichever is required to fit the available space. There is also a way to make it scale down if necessary but never scale up, by giving the downifneeded keyword instead of an empty object:

```
5c @Wide downifneeded @Scale @Box WARNING!
```

produces no scaling:

WARNING!

but

```
1c @Wide downifneeded @Scale @Box WARNING!
```

does produce scaling:

WARNING!

This is a good option if scaling is being used when a display is around the same width as the page; it scales only if this is needed to fit the display into the column, not otherwise.

8.7. Clipping

The @HClip symbol clips the following object horizontally to the available width:

```
@Box 1c @Wide @HClip WARNING!
```

produces

WAR!

The following object may be arbitrary as usual; for example, it could be an illustration included using @IncludeGraphic (Section 8.9).

We have used the @Wide symbol from Section 8.10 to make clear what the available width is in this small example (one centimetre), but @HClip will work in any context; for example, you could use it to clip a table entry, or a display.

The @HClip symbol has a shift option which determines which part of the clipped object is displayed. It may take on any value between 0.0, meaning to display the leftmost part (the default value), and 1.0, meaning to display the rightmost part:

```
@Box 1c @Wide @HClip shift { 1.0 } WARNING!
```

produces

WING!

To display the central part, use shift value 0.5. Notice that there is no unit of measurement attached to the value of shift.

There is also a @VClip symbol which works in exactly the same way, only vertically. The two symbols combine together naturally:

@Box 1c @Wide 0.2c @High @HClip @VClip WARNING!

produces

WΔR!

The shift options may be used as usual to determine which part of the two-dimensional area is displayed.

8.8. Mirror reflections

The @HMirror symbol produces a horizontal mirror reflection of the following object:

@HMirror AMBULANCE

produces

ECNALJUNCE

The @VMirror symbol produces a vertical mirror reflection of the following object:

```
@VMirror 5c @Wide @Box {
  @B { Pond life. } Pond life includes
  frogs, tadpoles, newts, salamanders,
  eels, and mosquito larvae.
}
```

produces

and mosquito larvae.

newts, salamanders, eels,

includes frogs, tadpoles,

Pond life. Pond life

As this example shows, the object to be mirror reflected may be arbitrary. We have used a @Wide symbol in this example to restrict the width of the result to be five centimetres wide. See the description of the @VShift symbol in Section 8.9 for what to do if your reflected object is not aligned properly with adjacent objects.

8.9. Including an illustration

The `@IncludeGraphic` symbol incorporates into a Lout document an illustration (that is, an encapsulated PostScript or EPS file) produced by other means. For the opposite process, using Lout to produce an illustration for inclusion in some other document, see Section 3.5.

For example, suppose the encapsulated PostScript file `su_crest.eps` contains the University of Sydney crest. Then

```
@IncludeGraphic su_crest.eps
```

produces



In general, the result produced by `@IncludeGraphic` is an object that may be scaled, clipped, rotated, made into a display or placed within a paragraph, just like any other object. Accolades for this remarkable flexibility should go to the PostScript page description language, whose extraordinary power makes the provision of this feature in Lout almost trivial.

The `@IncludeGraphic` command understands that files ending with any of the suffixes `.gz`, `-gz`, `.z`, `-z`, `_z`, and `.Z` are compressed files, and it will uncompress such files using the `gunzip` command before including them. The uncompressed version is stored in a file called `lout.eps` in the current directory, and removed after being copied into the output file.

If you place an included illustration in a line of text, or anywhere where you care about its alignment with things on each side, it will be positioned with its centre at the same height as the centre of the letter `x`. If this is not what you want, use the `@VShift` symbol from Section 8.10:

```
... +0.5f @VShift @IncludeGraphic ...
```

prints the illustration half of the current font size higher on the page than would otherwise have been the case, and

```
... -0.5f @VShift @IncludeGraphic ...
```

prints it half the current font size lower.

Sometimes you need to include the same EPS file many times, for example once per page. If it is a large file it can make the output file very large to include it over and over again. Lout offers a solution to this problem, in the form of the `@IncludeGraphicRepeated` symbol. You place this at the start of your document, like this for example:

```
@Include { doc }
@IncludeGraphicRepeated { su_crest.eps }
```

(note the braces around the following EPS file name). Adding `@IncludeGraphicRepeated` like this does not actually print the graphic anywhere on any page; on the contrary, it is guaranteed to not change the appearance of your document at all. What it does do is give Lout a hint that the

EPS file between the braces is likely to be included many times over in this document. Lout then handles this EPS file in a different way that involves copying it into the PostScript output file just once, no matter how many times it is included by subsequent `@IncludeGraphic` symbols.

When your EPS file would otherwise be included many times over, using `@IncludeGraphicRepeated` definitely makes your PostScript output file a lot shorter, and it usually makes it print faster as well. On the other hand, `@IncludeGraphicRepeated` uses Level 2 PostScript features which some older printers may not have, and it consumes a lot of memory in the printer. If memory runs out your job will not print properly, so use `@IncludeGraphicRepeated` with caution.¹

8.10. Precise object placement

This section offers some tips on placing objects precisely where you want them relative to each other. If your problem is to place objects precisely at some unusual point on the page, you probably need a margin note or the `@Place` symbol, for which see Section 2.4.

Precise object placement is not a subject with any clear boundaries, so this section is mainly a list of examples, covering the use of the `@OneCol`, `@OneRow`, `@Wide`, `@High`, `@HEExpand`, `@VExpand`, `@HShift`, `@VShift`, `@VStrut`, `@OverStrike`, `@ZeroHeight`, and `@ZeroWidth` symbols.

The `@OneCol` symbol causes the following object to be kept on one line. (The name stands for ‘one column’, which is a bit confusing unless you are an expert.) For example, you could use it to prevent hyphenation in a particular word, or to keep someone’s name together on one line:

```
@OneCol { Mr. Jones }
```

although there is also the `~` symbol for that. Similarly, `@OneRow` causes the following object to be kept in one column. It is commonly used to keep displays and list items together:

```
@IndentedDisplay @OneRow ...
```

and

```
@ListItem @OneRow ...
```

are the usual uses.

Loosely speaking, the `@Wide` symbol causes the object following it to have a particular width. It also has a `@OneCol` effect. Paragraphs within the object will be broken if necessary in order to satisfy the width restriction. More precisely, the result of the `@Wide` symbol is an object with the given width, with the following object fitting inside it, so having at most that width. Compare

```
5c @Wide @Box { A box }
```

which produces

¹A test file using `@IncludeGraphicRepeated` generated by the author is currently (Version 3.35) being displayed correctly in two PostScript viewers and converted to PDF correctly by the Unix `ps2pdf` command. This PDF file prints without any problems on the author’s printer, but the original PostScript file does not.

```
A box
```

with

```
@Box 5c @Wide { A box }
```

which produces

```
A box
```

In the first example, the only obligation on the box is to be at most five centimetres wide, so that it fits into the space allowed it. In the second example, the box is drawn around an object guaranteed to be exactly five centimetres wide. The width of the box itself will be five centimetres plus twice the box margin width. Any length (Section 1.2) is allowed, and the object following `@Wide` may be arbitrary as usual.

The `@High` symbol is like `@Wide`, only vertical. The two may be used together:

```
@Box 5c @Wide 5c @High { A box }
```

produces

```
A box
```

Be careful when using `@High` to allow enough space for whatever is inside. An error message will be printed if you don't, and the `@High` symbol will be ignored.

Instead of a particular width, it is quite common to want something to be as wide as possible. For this there is the `@HEExpand` symbol:

```
@IndentedDisplay @Box @HEExpand { A box }
```

produces

```
A box
```

Notice how `@HEExpand` is placed after the `@Box` symbol, to ensure that the box is drawn around something as wide as possible, analogously to the second `@Wide` example above. Lout has carefully worked out that 'as wide as possible' means the column width minus the indent width and box margins.

Here is an example of @Wide and @HEExpand working together:

Name: _____
Address: _____

The problem is to get the underlines to be as wide as possible. The solution is

```
@Box margin { 0.3c } 8c @Wide {
Name: @Underline @HEExpand
@LP
Address: @Underline @HEExpand
}
```

Each @HEExpand symbol produces for its result an object which is as wide as possible, in this example containing nothing. When that object is underlined, the underline is as wide as possible.

Although there is a corresponding @VExpand symbol, it is not very useful alone because ‘as high as possible’ does not mean ‘down to the foot of the page’ as you would expect. It is mainly useful within @High.

The @HShift and @VShift symbols control the alignment of objects with neighbouring objects. There are not many places in document formatting where alignment actually matters. Ordinary lines of text are one of them:

faults such as {-0.3f @VShift s}lipped letters

produces

faults such as _slipped letters

with the object following @VShift aligned with neighbouring objects such that it appears 0.3 times the current font size lower than it normally would. The object following @VShift may be arbitrary as usual. Examples requiring @HShift are very rare; one appears below.

The @VStrut symbol is used to compensate for missing letter ascenders and descenders. For example, the three boxes e, f, and g look ragged because their contents differ in their ascenders and descenders. The solution is to insert a *strut* into each box: an invisible object of zero width whose height is that of a letter with both an ascender and a descender. This is done with the @VStrut symbol, which attaches such a strut to the following object:

```
@Box { @VStrut e }, @Box { @VStrut f }, and @Box { @VStrut g }
```

produces

e, f, and g

The @VStrut symbol has above and below options which determine how high and low (relative to the middle of the letter ‘x’) the strut is to go. Their default values are both 0.5f.

Missing descenders can cause list items to appear unequally spaced, because the space

between list items is ordinarily measured from the bottom edge of the higher list item to the top edge of the lower one, rather than from baseline to baseline. Enclosing the last word of the troublesome items in `@VStrut` will fix this problem.

Alternatively, and possibly more conveniently, Version 3.33 of Lout has added a strut option to the `@Font` symbol, used alone like this:

```
strut @Font ...
```

or in combination with other values suited to go to the left of `@Font`, like this:

```
{ strut +2p } @Font ...
```

This causes a vertical strut to be added to every word under the influence of the `@Font` symbol. The height of this kind of strut is fixed at the height of the highest character in the font, and its depth at the depth of the deepest character, as recorded by the ‘font bounding box’ stored with the description of the font. For example,

```
strut @Font { @Box { e }, @Box { @f }, and @Box { g } }
```

produces

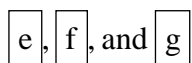

If you need many struts, it might pay to include `strut` in the `@InitialFont` option of your document, so that it applies everywhere.

The `@OverStrike` symbol causes the objects on each side of it to be overstruck:

```
= @OverStrike "/"
```

produces



The objects to be overstruck may be arbitrary as usual. For example, Section 10.2 recommends this symbol for overstriking two graphs, to get what appears to be one graph with two coordinate systems superimposed. The second object is printed after the first and will paint over it.

Sometimes the best way to get Lout to do what you want is to make it pretend that some object has zero width or height, using the `@ZeroWidth` and `@ZeroHeight` symbols. Lout will format the overall document as though the object in question had zero width or height, but it will still print the entire object.

For example, you might have an inline equation that causes the line spacing to increase to accommodate it – 2^{2^N} say – but you would rather it didn't. Writing

```
@ZeroHeight @M { 2 sup 2 sup N }
```

causes Lout to pretend that the object has zero height, and so it will not increase the line spacing around this version of 2^{2^N} , as you can see.

The `@HShift` and `@VShift` symbols provide a way to move the printed object with respect

to the zero-width one:

```
{@ZeroWidth 1w @HShift “}My dear Sir Thomas!” cried  
Mrs. Norris, red with anger, “Fanny can walk.”
```

This example produces ‘hanging punctuation’:

```
“My dear Sir Thomas!” cried  
Mrs. Norris, red with anger,  
“Fanny can walk.”
```

The double quotes are printed at zero width, and 1w @HShift ensures that they appear just to the left of the empty object that Lout thinks it is placing, so that they protrude into the margin rather than overstriking the next word (the Expert’s Guide [5] explains the w unit of measurement).

Some of the symbols described in this section are Lout primitives, described in full detail in the Expert’s Guide [5]; and that is also the place to look for more information about precise object placement. In particular, the Lout primitives described there for horizontal and vertical concatenation, / and |, offer possibilities beyond what has been described here.

Chapter 9. Diagrams

This chapter describes how to use the `@Diag` symbol¹ to make diagrams like this one:

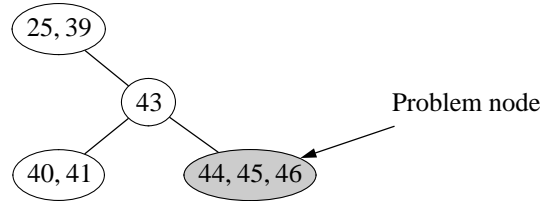

`@Diag` offers nodes and links, arrows, labels, coordinates, tree diagrams, and syntax diagrams.

9.1. Introduction

To use the `@Diag` symbol you first need to include its setup file. For example, suppose you have an ordinary document with tables:

```
@SysInclude { tbl }
@SysInclude { doc }
@Doc @Text @Begin
...
@End @Text
```

Change this to

```
@SysInclude { tbl }
@SysInclude { diag }
@SysInclude { doc }
@Doc @Text @Begin
...
@End @Text
```

This provides everything you need for making diagrams.

The result of the `@Diag` symbol is an object in the usual way. A diagram is commonly made into a centred display, like this:

```
@CentredDisplay @Diag { ... }
```

¹Starting with Version 3.18 of Lout, the `@Diag` symbol was enhanced with the `@ANode`, `@BNode`, and `@CNode` symbols described in Section 9.2, and with the symbols for syntax diagrams described in Section 9.8.

Prior to Version 3.09 of Lout, this chapter described a symbol called `@Fig` which was similar to but more primitive than `@Diag`. For backward compatibility the `@Fig` symbol is still available and still works exactly as described in the old documentation, but there is no reason to use it in new documents.

or into a floating figure, like this:

```
@Figure
  @Caption { ... }
  @Diag {
    ...
  }
```

but it could be an entry in a table, a word in a paragraph, or anything else.

Most uses of @Diag contain a *nodes part* and a *links part*:

```
@Diag {
  nodes part
  //
  links part
}
```

This reflects @Diag's view of the world as consisting of *nodes* (circles, squares, and so on), which have to be put in their right places and then joined with *links* (lines, arrows). The technical meaning of the // symbol does not concern us here; it simply serves to divide the two parts.

For example, here is a nodes part containing two nodes separated by a @DP symbol that (as usual) leaves some vertical space between them:

```
@Ellipse { Hello, world }
@DP
@Square @| x
```

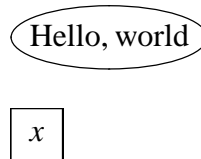

Node symbols like @Ellipse and @Square follow a familiar pattern: they consume the following object, which may be arbitrary, draw a shape around it, and give back the resulting object. To insert links, the nodes must first be given names, called *tags*, using the :: symbol:

```
A:: @Ellipse { Hello, world }
@DP
B:: @Square @| x
```

Then a link from A to B may be added to the links part:

```
@Diag {
  A:: @Ellipse { Hello, world }
  @DP
  B:: @Square @| x
  //
  @Link from { A } to { B }
}
```

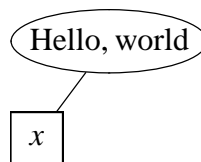

Subsequent examples will often omit the enclosing @Diag { }.

9.2. Nodes

@Diag has one basic symbol for creating nodes. It is called @Node, and it takes the following object and encloses it in an outline whose shape is determined by the outline option:

```
@Node
  outline { curvebox }
{ Hello, world }
```



As Section 9.10 explains, the outline option may be used to produce an outline of any shape. There are also nine values that produce standard shapes: box, curvebox, shadowbox, square, diamond, polygon, isosceles, ellipse, and circle.

The shape of the outline is determined by the outline option, but its size and position depend on the size and position of its *base*: the following object with a small margin around it. For example, this is how a circle is positioned over its base (shown in grey):

```
@Node
  outline { circle }
{ Hello, world }
```



Lout works only with the base, having no idea where the outline is, which explains why this circle is too high for the space allowed it. Section 9.12 shows how each of the standard outlines is positioned over its base.

The @Node symbol has many options, but all of them without exception share the following very useful property: they may be given to the @Diag symbol as well, where they apply to every node in the diagram:

```
@Diag
  outline { circle }
{
  @Node @I a
  @DP
  @Node @I b
}
```



These options also appear in the setup file (diag); if set there, they apply to every node in every diagram of the document. As the number of nodes increases, it becomes very tedious and error-prone to duplicate options at all the nodes. Giving each option just once, at the @Diag symbol or in the setup file, saves time and makes it easy to change all the nodes into squares or any other shape later on. Any setup file option may be overridden in a diagram by giving the option to its @Diag symbol; any @Diag option or setup file option may be overridden at any node by giving the option again there.

Sometimes a diagram contains several different node types, each with its own combination of options (for example, the syntax diagrams of Section 9.8 have three node types). To handle these cases there are five alternative versions of the @Node symbol, called @ANode, @BNode, @CNode, @DNode, and @ENode. These have exactly the same options as @Node, but the *default* values of these options are different, in that they come from @Diag options, or else setup

file options, that have an extra letter in front of their name: a, b, c, d, or e. Here is a small example (see later in this section for the font option):

```
@Diag
  aoutline { box }
  afont { Italic }
  boutline { curvebox }
  bfont { Bold }
{
  @ANode identifier
  @DP
  @BNode keyword
}
```



Note that when giving an option directly to @ANode, @BNode, @CNode, @DNode, and @ENode, the initial a, b, c, d, or e used with @Diag and in the setup file is omitted.

To save time in simple cases, @Diag provides nine other node symbols called @Box, @CurveBox, @ShadowBox, @Square, @Diamond, @Polygon, @Isosceles, @Ellipse, and @Circle. These are just abbreviations for @Node with the appropriate value of outline, nothing more. They take the same options as @Node (except that outline is already fixed), and everything works in the same way.

There is a shadow option which determines the depth of the shadow in shadow boxes:

```
@Node
  outline { shadowbox }
  shadow { 0.4f }
{ WARNING }
```



This example shows the default value, 0.4 times the current font size. For polygons there is a sides option for specifying the number of sides, and an angle option for rotating the outline:

```
@Polygon
  sides { 5 }
```

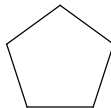

```
@Polygon
  sides { 5 }
  angle { 0d }
```

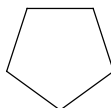

Setting angle to 0d causes the first vertex to be placed directly underneath the centre, and as the angle increases, the position of the first vertex rotates anticlockwise. The defaults are 3 sides and the angle that gives the polygon a horizontal base (i.e. 180 degrees divided by the number of sides). Thus the two cases with symmetry about a vertical axis are obtained by the default angle and 0d respectively, which is convenient. The shadow, sides, and angle options may be given to any node, and also to @Diag and in the setup file, where they apply to every node as usual. However, they only affect the appearance of shadow boxes and polygons, respectively.

The outlinestyle, outlinedashlength, and outlinewidth options apply to any node and affect

the appearance of the outline:

```
@CurveBox
  outlinestyle { solid }
  outlinedashlength { 0.2f }
  outlinewidth { thin }
{ Hello, world }
```

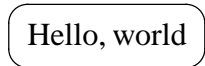

This example shows the default values of these options. The `outlinestyle` option's allowed values include `solid`, `dashed`, `cdashed`, `dotted`, and `noline`. There are also six values for mixing dots and dashes (Section 9.12).

The `dashed` option makes all dashes the same length, whereas `cdashed` halves the length of the first and last dash on each segment, which usually looks better:

```
@CurveBox
  outlinestyle { cdashed }
{ Hello, world }
```

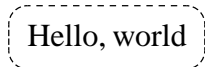

The length of dashes is `outlinedashlength`, and the distance between dashes or dots is at most `outlinedashlength`, reduced to make the dashes or dots fit evenly. The `outlinewidth` option determines the width of the line, dashes, or dots, and may be `thin`, `medium`, `thick`, or any length. The values used for `thin`, `medium`, and `thick` are `0.04f`, `0.08f`, and `0.12f`.

The `outlinestyle` option may contain a sequence of the values mentioned above, meaning that they are to be applied in turn to each segment of the outline:

```
@CurveBox
  outlinestyle { solid cdashed }
{ Hello, world }
```

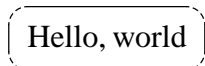

If there are more segments than values, `outlinestyle` cycles back to the first value again; this is why a single value is applied to all segments. Section 9.12 shows how each of the standard shapes is divided into segments.

The node symbols of `@Diag` are quite separate symbols from the three basic box symbols of Section 8.3. Although much is the same, one obvious difference between the two is that to get no outline in those boxes you use `linewidth { none }`, whereas to get no outline here you use `outlinestyle { noline }`. The basic boxes can only draw the outline solid or not at all, and their options have been kept simple to reflect that.

Nodes may be painted any of the colours listed in Section 8.1, using the `paint` option:

```
@Box
  paint { grey }
@Diamond
  outlinestyle { noline }
  paint { white }
{ Hello, world }
```

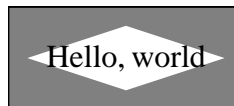

In this example the object following `@Box` is a diamond containing `Hello, world`. The default

value of paint is none, a special value (not a colour) meaning don't use any paint. There is also a texture option which causes this paint to be applied with a given texture. This works exactly like the texture option described in Section 8.3, so we'll say no more about it here.

When painting it is important to know what order things are done in, because anything put down earlier will disappear under the paint. This is why none and white are different. Painting is done first, then boundaries, and finally the following object.

Each node symbol has font and break options which may be used to set the font and paragraph breaking style of the following object:

```
@Box
  font { Helvetica Base }
  break { clines }
{
WARNING
DANGEROUS
PENGUINS
}
```

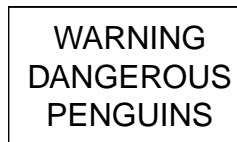

Both options have empty default values, which leave the font and break style unchanged. There is also a format option for making more radical changes to the appearance of the following object:

```
@Box
  format {
    {0.8 1.5} @Scale @S @Body
  }
{
Dangerous Penguins
}
```



The result is the format option with any @Body symbol within it replaced by the following object. These are very useful when attached to the @Diag symbol:

```
@Diag
  font { Helvetica Base }
  break { clines }
  format { { 0.8 1.5 } @Scale @S @Body }
{
...
}
```

since then they apply to every node, as usual, thereby eliminating a lot of tedious, error-prone duplication of formatting information at each node.

The margin option determines the size of the margin added to the following object:

```
@Box
  margin { 0c }
{ Hello, world }
```

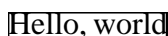

These margins are included in the node's base (described above), so a larger margin enlarges the base and hence the outline as well. The default value of `margin` is `0.6f` (six-tenths of the current font size), and so the margin will automatically increase when the font size does, for example in overhead transparencies.

The `margin` option adds the same margin to all four sides. For finer control, the `hmargin` option determines the horizontal (left and right) margins only, overriding `margin`. Similarly, the `vmargin` option determines the vertical (top and foot) margins. There are also `leftmargin`, `rightmargin`, `topmargin`, and `footmargin` options which override `margin`, `hmargin`, and `vmargin`.

When nodes appear side by side, the `valign` option is useful for controlling their vertical position with respect to each other. For example,

```
@Diag
  valign { foot }
{
  @Box font { 24p } Big
  @Box font { 8p } Small
}
```

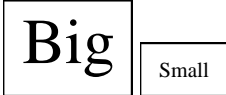

causes the feet of the boxes to be aligned. In this example it is applied to all nodes at once, but of course it can be applied to individual nodes as well. The value of `valign` can be a length, which means that the point of alignment is to be that far down from the top of the base (including margins); or it may be `top`, `ctr`, or `foot`, meaning alignment through the top, centre (the default value), or foot.

The `vsize` option specifies a particular height for a node (not including margins):

```
@Diag
  vsize { 2f }
{
  @Box font { 24p } Big
  @Box font { 8p } Small
}
```

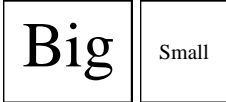

The font size used when calculating `vsize` is not affected by the value of any font option. If the following object is too tall for the chosen height, Lout will print a warning message ('forced to enlarge @High', probably) and enlarge the base.

There is a `vindent` option which is effective only when `vsize` is used. It controls where in the vertical space the following object is to appear:

```
@Diag
  vsize { 3f }
{
  @Box vindent { top } Top
  @Box Centre
  @Box vindent { foot } Foot
}
```

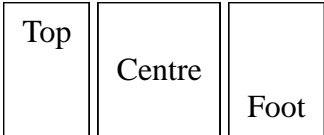

The value may be `top` for at the top, `ctr` (the default value) for in the centre, `foot` for at the foot,

or a length, meaning that distance down from the top. These values are the same as for the `valign` option.

Small discrepancies in the size of nodes can be very annoying, particularly when the nodes appear side by side:

```
@Diag
{
  @Box Hole @Box in
  @Box my @Box pocket
}
```

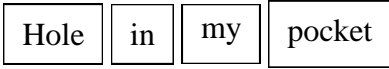

These are caused by the slightly different heights of the objects within the nodes. Selecting a fixed vertical size for all nodes goes some way towards solving this problem:

```
@Diag
  vsize { 1f }
{
  @Box Hole @Box in
  @Box my @Box pocket
}
```



The size `1f` is a good choice because most fonts are designed to be `1f` high from the top of the tallest character to the foot of the deepest. However, there is still a problem with the baselines of the words being misaligned. A better solution is to insert a *vertical strut* into each node: an invisible object with zero width and height equal to `1f`. This is done using the `vstrut` option:

```
@Diag
  vstrut { yes }
{
  @Box Hole @Box in
  @Box my @Box pocket
}
```



The `vstrut` option may be `yes`, `no` (the default value), or a length, meaning to insert a strut of this height. So `vstrut { yes }` is equivalent to `vstrut { 1.0f }`.

There are `halign`, `hsize`, `hindent`, and `hstrut` options which work horizontally exactly as `valign`, `vsize`, `vindent`, and `vstrut` work vertically, except that they use `left` and `right` where the vertical ones use `top` and `foot`. The best way to fix horizontal size discrepancies is with `hsize`, not `hstrut`.

9.3. Links

`@Diag` has one basic symbol for creating links, called `@Link`. It draws a link between two points or nodes given by `from` and `to` options, along a path given by a `path` option:

```
@Link
  path { ... }
  from { ... }
```

to { ... }

Unlike @Node, @Link has no following object.

The path option may be used to produce a link of any shape, as Section 9.10 explains. There are also values that produce standard paths. These are listed in full in the summary (Section 9.12); here is a sample:

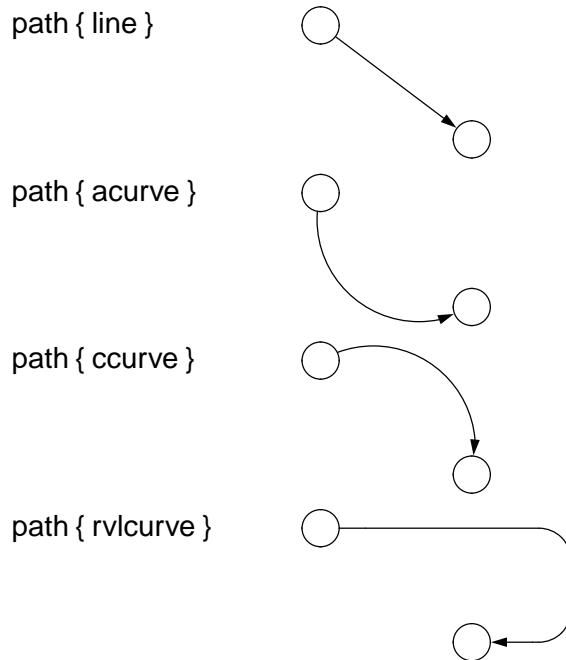

The name of the last one is a reminder that it goes right, then vertically, then left, with curved corners. The *acurve* and *ccurve* values produce circular arcs, anticlockwise and clockwise respectively, lying on the circle passing through the endpoints, or through the centres of the endpoints when they are tags denoting nodes. There is also *curve* which is an abbreviation for *acurve*. All these standard paths are defined in a way that makes sense no matter where the two nodes are relative to each other, except that no promise of a sensible result is made for two nodes very close together.

@Link has two options, *bias* and *radius*, that may be used to fine-tune the path. The *bias* option determines the maximum distance that a curve is permitted to stray:

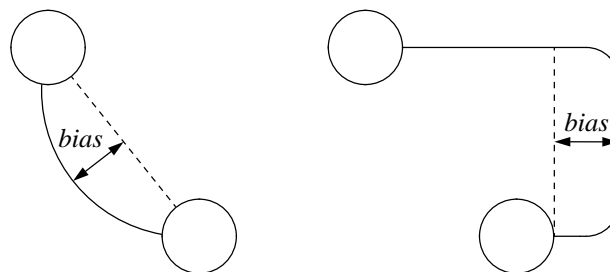

The *radius* option does *not* apply to *acurve* and *ccurve*; rather, it determines the radius of the arcs at the corners of *rvlcurve* and its kin. A very large radius will be reduced to the largest reasonable value, which provides a way to get a semicircle at the right in an *rvlcurve*.

Lout has no idea where the path is wandering, and cannot take it into account when placing a diagram on the page:

```
@Link
  path { ccurve }
  bias { 2c }
```

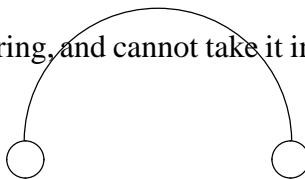

In such cases you have to arrange for the extra space yourself, by adding an extra paragraph symbol, blank row or column in a table, or whatever.

As with the options of `@Node`, the options of `@Link` may all be given to `@Diag` as well, where they apply to every link in the diagram, unless overridden in the usual way. They also appear in the setup file, where they apply to every link in every diagram of the document, unless overridden.

There are `pathstyle`, `pathdashlength` and `pathwidth` options which affect the appearance of the path in the same way as the `outlinestyle`, `outlinedashlength` and `outlinewidth` options of `@Node` affect the outline. When `pathstyle` contains just one value (as opposed to a sequence of values) `@Diag` tries to divide the path into fewer segments than it would otherwise, to make dashed and dotted paths look as good as possible. There is also a `pathgap` option which affects only doubleline paths; it determines the gap between the centres of the two lines.

The `@Link` symbol has an `arrow` option, which adds an arrowhead to the end of the link:

```
@Link
  arrow { yes }
```



Its value may be `no` (the default), `yes`, `forward` (which is the same as `yes`), `back`, or `both`:



```
@Link
  arrow { both }
```



`@Link` has three options for controlling the appearance of arrowheads: `arrowstyle`, `arrowwidth`, and `arrowlength`. Although every link symbol has these options, for consistency it is almost always better to set the corresponding options to the `@Diag` symbol, which applies them to every arrow in the diagram:

```
@Diag
  arrowstyle { solid }
  arrowwidth { 0.3f }
  arrowlength { 0.5f }
  {
    ...
  }
```

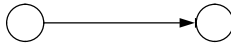
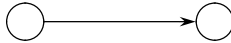
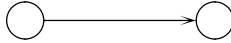
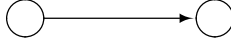
This shows the default values: a solid arrowhead like the ones above, 0.3f wide (across) and 0.5f long. The `arrowwidth` and `arrowlength` options may be any length; it may be necessary to decrease `arrowwidth` when many arrows enter one node. The full list of possible values for `arrowstyle` is

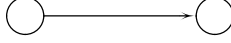
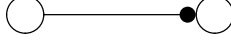
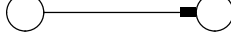
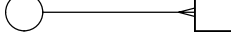
<code>arrowstyle { solid }</code>	
<code>arrowstyle { solidwithbar }</code>	
<code>arrowstyle { halfopen }</code>	
<code>arrowstyle { open }</code>	
<code>arrowstyle { curvedsolid }</code>	
<code>arrowstyle { curvedhalfopen }</code>	
<code>arrowstyle { curvedopen }</code>	
<code>arrowstyle { circle }</code>	
<code>arrowstyle { box }</code>	
<code>arrowstyle { many }</code>	

The reader is invited to admire the beautifully sharp points on these arrowheads.¹ The arrow with style `solidwithbar` has a bar at the tip of the arrowhead, whose length equals the width of the arrow and whose width is `pathwidth`, like this:



This example shows that half of the bar extends beyond the area allocated to the arrow, so that if two of these arrows meet from opposite directions, their bars will exactly overstrike.

Corresponding with `arrowstyle`, `arrowwidth`, and `arrowlength`, there are `backarrowstyle`, `backarrowwidth`, and `backarrowlength` options which determine the style and size of the back arrow; it doesn't have to be the same style or size as the forward arrow:

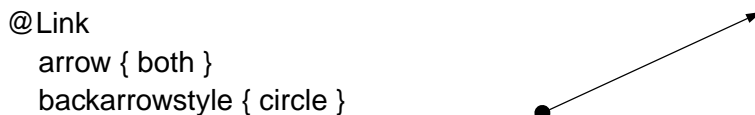

It is also possible to place an arbitrary object at the beginning or end of a link, using the `fromlabel` and `tolabel` options of Section 9.5.

To save time in common cases, `@Diag` provides link symbols, each of which is just `@Link` with one of the standard paths already set: `@Line`, `@Curve`, `@CCurve`, `@RVLCurve`,

¹The outlines of all nodes and arrowheads are drawn on the inside of the geometrical curve defining them, not centred over the curve as is common in PostScript documents. Hence, the arrowheads and node outlines intersect at a true geometrical point; they do not overlap by one line width. Furthermore, the standard link paths terminate at the base of the arrowhead, not at the point; the arrowhead itself is responsible for continuing the link path, at the appropriate width (although never dashed or dotted), from its base to its point, and hence can and does ensure that the link path does not overstrike and thicken the point of the arrow.

and so on. There are also symbols in which the `arrow` option is set to `yes` in addition: `@Arrow`, `@CurveArrow`, `@CCurveArrow`, `@RVLCurveArrow`, and so on. See the summary (Section 9.12) for the full list of these symbols. You will still need the `arrow` option to get backward arrows and double-ended arrows.

9.4. Tags

In addition to drawing the outline, each of the standard node types also attaches names, called *tags*, to certain points. For example, the `@Ellipse` symbol creates nine tags:

`@Ellipse`

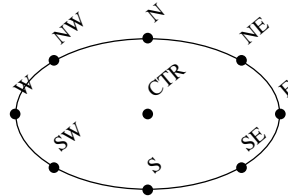

The standard link symbols also create tags:

`@Link`

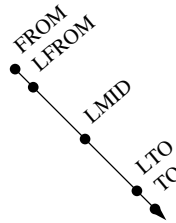

The names and positions of all standard tags may be found in the summary (Section 9.12) at the end of this chapter. Each tag stands for a point, and may be used wherever a point is required:

```
@Ellipse { Hello, world }
//
@Link from { SW } to { SE }
```

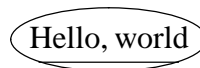

A tag may only be used later in the text of the diagram than the place where it is defined.

Standard tags like `N` and `S` are not much use as they are, since in general there will be many nodes and hence many `N` and `S` tags. The retagging symbol, `::`, solves this problem:

`A:: @Ellipse`

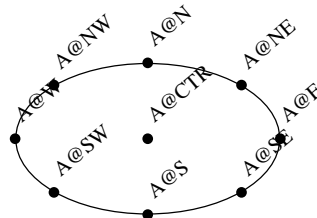

Within the following object, the points have their original tags, but afterwards the names are changed by prefixing the word preceding `::`, plus a `@` character, to each one. These longer tags may be used exactly like the others:

```
A:: @Ellipse { Hello, world }
//
@Link from { A@SW } to { A@SE }
```

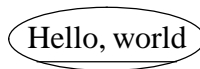

The retagging symbol may be applied to links, and indeed to arbitrary objects; it will retag every tag within the following object, even tags that have already been retagged:

```
A:: {
  1:: @Ellipse
    vsize { 1.0c }
    hsize { 2.5c }
    @DP
    @DP
  2:: @Ellipse
    vsize { 1.0c }
    hsize { 2.5c }
}
```

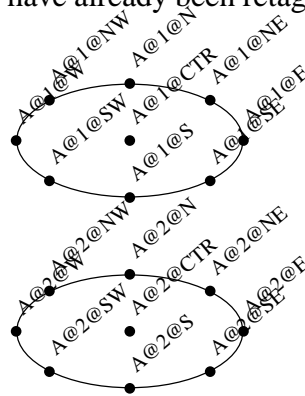

In practice one usually only retags individual nodes. It is best to use only upper-case letters in tags, because Lout and PostScript have tags of their own containing lower-case letters, and any mixup causes total disaster. Although the above example uses digits, these can cause problems since a tag like `A@1@S` will be interpreted by Lout as `A@1` followed by the `@S` small capitals symbol. (This problem can itself be avoided by enclosing the entire tag in quotes, as in `"A@1@S"`; this works because tags are just words to Lout, although they are symbols to PostScript. But better to avoid the whole problem by not using digits.)

When a tag lies within the object following some node, it is automatically retagged in this way with tag `IN`. For example, in

```
@Square
@Circle Hello
```

the circle lies within the square, and what you get in effect is

```
@Square
IN:: @Circle Hello
```

This prevents confusion between the tags of the inner and outer nodes. This retagging cannot be left to the user's discretion, owing to unexpected effects on the positioning of labels of the outer node if inner tags are not retagged.

Although `from` and `to` are just two of several options within `@Diag` where a point is expected, and hence where a tag may be given, they have a special virtue not shared by any other options. It is possible to give the name of an entire node, not just a tag denoting one point, to them:

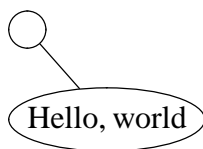

```
A:: @Circle
@DP
B:: @Ellipse { Hello, world }
//
@Link from { A } to { B }
```



This will select a point on the outline of the named node, appropriate to the type of link being drawn. It is extremely useful, of course, but potentially confusing: A and B do not denote points and are not tags, strictly speaking, at all.

The :: symbol has a restrict option which can be used to save printer memory in deeply nested structures (such as the syntax diagrams of Section 9.8) by restricting the tags promoted by :: to a limited set and discarding the rest:

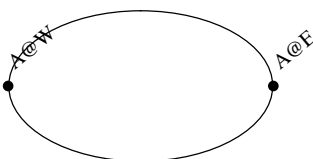
```
A:: restrict { (E) (W) } @Ellipse
```



The tags to be preserved appear within the restrict option, each enclosed in parentheses. Care is needed with this option: all of the listed tags must actually exist in the following object. If not, the result will be a PostScript error mentioning the get command.

9.5. Labels

Diagrams often contain small *labels* adjacent to their nodes and links:

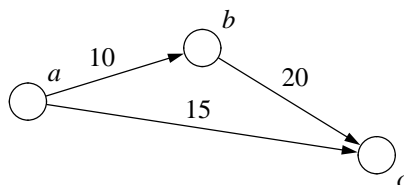

Each node may have up to four labels, called alabel, blabel, clabel, and dlabel:

```
@Ellipse
  alabel { a }
  blabel { b }
  clabel { c }
  dlabel { d }
{ Hello, world }
```

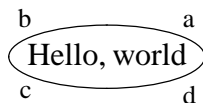

Links also have labels, five in fact:

```
@Link
  fromlabel { f }
  xlabel { x }
  ylabel { y }
  zlabel { z }
  tolabel { t }
```

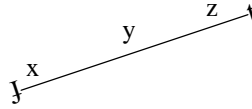

The `fromlabel` and `tolabel` options are positioned directly over the endpoints of the link, and `fromlabel` is by default printed at a funny angle, because these labels are the means of attaching arrowheads to links:

```
@Link
  tolabel { @SolidArrowHead }
```

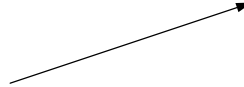

`@SolidArrowHead` is a symbol available for use anywhere whose value is an object in the shape of a small solid arrowhead. The arrowhead options of Section 9.3 work by setting `fromlabel` and `tolabel` in exactly this way. Usually it is best to forget about `fromlabel` and `tolabel`, and think of links as having three labels: `xlabel` near the start, `ylabel` in the middle, and `zlabel` near the end.

Adding a label will not change the size of the diagram or the position of any node, link, or other label. Although a label may be an arbitrary object, it is treated as having zero size and will overstrike anything that happens to be where it wants to go.

There are options for controlling the appearance and position of labels. These are described below mainly for `alabel`, but there are corresponding options for all nine labels.

The `alabelfont` and `alabelbreak` options determine the font and paragraph breaking style of the label:

```
@Ellipse
  alabel { a }
  alabelfont { -2p }
  alabelbreak { ragged nohyphen }
{ Hello, world }
```

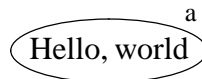

This example shows the default values of these two options; `-2p` explains why the labels in earlier examples were printed in a smaller font size. There is also an `alabelformat` option which allows for more radical changes in appearance:

```
@Ellipse
  alabel { a }
  alabelformat { @Box @I @Body }
{ Hello, world }
```

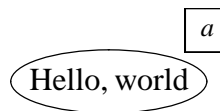

The value attached to the ellipse will be the value of `alabelformat`, with any `@Body` symbol within it replaced by the value of the `alabel` option. This example produces boxed italic labels.

Nodes also have `nodelfont`, `nodelfontbreak`, and `nodelfontformat` options which work in the same way but affect all of the node labels, not just one:

```
@Ellipse
  nodelabelformat
    { @Box @| @Body }
  alabel { a }
  blabel { b }
{ Hello, world }
```

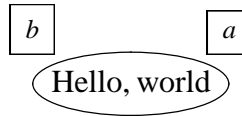

Links similarly have linklabelfont, linklabelbreak, and linklabelformat options which affect all the link labels (except fromlabel and tolabel, since that would produce results that people do not expect.) The @Diag symbol also has these options, in the usual way, and they are extremely useful there:

```
@Diag
  nodelabelfont { Slope -2p }
  linklabelformat { \ \@Body\ }
  hsize { 1.8c }
{
  A:: @Ellipse alabel { a } { OK }
  @DP
  @DP
  B:: @Ellipse alabel { b } { FAULT }
  //
  @Arrow from { A } to { B } ylabel { sig }
}
```

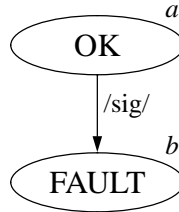

These settings specify that every node label will be set in italics, two points smaller than the surrounding text, and that every link label will appear between two / characters, also two points smaller because the default value of linklabelfont still applies. Of course, it remains open to any node or link to override these settings by supplying its own label options.

The remaining five label options, alabelpos, alabelangle, alabelprox, alabelmargin, alabelctr, and alabeladjust, affect the position of the label. Don't be daunted by the number of options. As previous examples have shown, they all have sensible default values and thus need to be set only rarely.

Each label inhabits its own characteristic region of the node or link: alabel in the north-east corner of the node, ylabel halfway along the link, and so on. This general location of the label is defined by the alabelpos option. Here are the default values for all nine labels:

```
@Node
  alabelpos { NE }
  blabelpos { NW }
  clabelpos { SW }
  dlabelpos { SE }
```

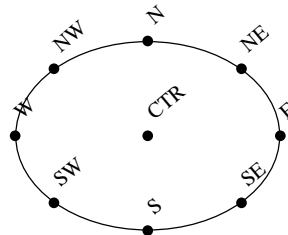

```
@Link
  fromlabelpos { FROM }
  xlabelpos { LFROM }
  ylabelpos { LMID }
  ylabelpos { LTO }
  tolabelpos { TO }
```

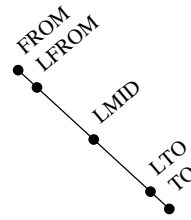

Thus, by changing `clabelpos` to `S` you can move the position of the `clabel` label to beneath the node. You can do this for every node by setting this option in the `@Diag` symbol, as was done for the formatting options above.

In a similar vein, there is an `xindent` option which controls how far from the start of the link the `LFROM` tag, and hence the `xlabel`, will appear. A similar option, `zindent`, determines how far from the end of the link the `LTO` tag and hence the `zlabel` will appear:

```
@Link
  xindent { 1f }
  zindent { 2f }
```

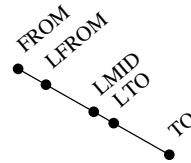

Both options have default value `0.8f`.

The `alabelangle` option determines the angle at which the label is printed:

<code>alabelangle { horizontal }</code>	Horizontal (the default)
<code>alabelangle { aligned }</code>	Aligned with the node outline or link path
<code>alabelangle { perpendicular }</code>	Perpendicular to the outline or link path

The `alabelprox` option determines where in the proximity of `alabelpos` the label is printed:

<code>alabelprox { above }</code>	Above the node outline or link path (the default for link labels)
<code>alabelprox { below }</code>	Below the node outline or link path
<code>alabelprox { left }</code>	To the left of the node outline or link path
<code>alabelprox { right }</code>	To the right of the node outline or link path
<code>alabelprox { inside }</code>	Inside the node outline or on the left of the link path going from from to to
<code>alabelprox { outside }</code>	Outside the node outline or on the right of the link path going from from to to (the default for node labels)

The `alabelmargin` option adds a margin around all four sides of the label, thereby moving it away from `alabelpos` irrespective of which direction it happens to lie in:

```
@Ellipse
  label { a }
  alabelmargin { 0f }
{ Hello, world }
```

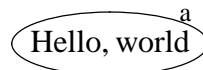

The default value is `0.2f`, and so there is scope for some reduction as well as increase.

`@Diag` takes careful account of the `alabelangle` option, the `alabelprox` option, the direction

that the node outline or link path is heading, and which label it is, and places the label in a way that looks good nearly always. When it doesn't, the remainder of this section should help.

The `alabelangle` option may be given an arbitrary angle, and then the label will be printed at that angle. There are also the special values `parallel` and `antiparallel`, which give the direction that the node outline or link path is going at that point and its opposite. These are the default values for `tolabelangle` and `fromlabelangle` respectively, which explains why arrowheads point the right way. The `aligned` value above is one of these two angles, the one closest to 0d.

The `alabelprox` option may be N, S, E, W, NE, SE, NW, SW, NNW, NNE, SSW, SSE, or CTR:

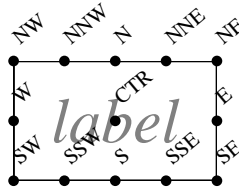

meaning that the indicated point of the label will coincide with `alabelpos`. These points lie on the outside of the margins added by `alabelmargin`.

The six values of `alabelprox` given earlier (`above`, `below`, etc.) all produce one of N, S etc. for their ultimate result; which one they produce depends on the direction the outline or link is going at that point. For example, `above` produces `SE` when the outline or link is going from northeast to southwest or vice versa, `SW` when the outline or link is going from northwest to southeast and vice versa, and `S` when it happens to be exactly horizontal. There is also a dependence on which label it is: for example, if it is `xlabel` and the direction happens to be vertical, the result is `NW`.

The preceding discussion is all under the assumption that the `alabelctr` option is `no`. When it is `yes`, a small adjustment is made to the position of the label. The selected corner or side midpoint of the label will no longer coincide with `alabelpos`, although it will still lie on the straight line passing through `alabelpos` at the angle of `alabelpos`. The corner or side midpoint slides up or down this line to the point which minimises the distance from `alabelpos` to the centre of the label. Only `ylabelctr` has `yes` for its default value; the `y` label often looks better centred when this adjustment is made, particularly on lines with shallow but non-zero slope:

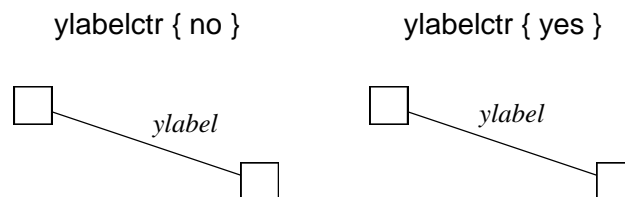

since it is then the centre of the label which is centred on the link, rather than one of its corners.

Finally, when all else fails there is an `alabeladjust` option which translates the label by an arbitrary amount:

```
alabeladjust { -0.5c 1.5c }
```

causes the label to appear 0.5 centimetres to the left of and 1.5 centimetres above the point where it otherwise would have done.

9.6. Positioning

Once the nodes of the diagram are in place, @Diag can be trusted to look after the rest: links to standard outlines will terminate neatly on their boundaries, labels will not overstrike links no matter what direction they are heading, and so on. The great weakness of @Diag is in positioning the nodes. This is partly because ‘what pleases the eye’ is the positioning rule in many diagrams, and an interactive system is really needed in such cases; and partly because, even when the rule is more formal (for example, when the nodes are to be laid out in a grid), @Diag does not have symbols to produce it anyway.

Previous examples have used @DP for getting nodes one under another, and white space between nodes for getting them side by side, but this is very primitive. This section suggests three better ways: using @Tbl, using @Graph, and using coordinates; and the following section adds a fourth, using @Diag’s tree-drawing symbols. It’s a bit of a jumble.

The @Tbl symbol (Chapter 6) is a good choice when the nodes have any kind of grid-like arrangement:

```
@Diag {
@Tbl
  aformat { @Cell A | @Cell B | @Cell C }
  marginhorizontal { 0.5c }
  marginvertical { 0.25c }
{
@Rowa
  B { A:: @Square }
@Rowa
  A { B:: @Square }
  C { C:: @Square }
@Rowa
  B { D:: @Square }
}
//
@Arrow from { A } to { B }
@Arrow from { A } to { C }
@Arrow from { B } to { D }
@Arrow from { C } to { D }
@Arrow from { A } to { D }
}
```

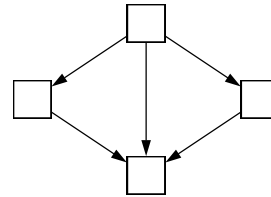

The table occupies the nodes part. Tags may have the same name as columns; the two can never conflict.

Similarly, the @Graph symbol from Chapter 10 has an objects option which can place arbitrary objects, including labelled nodes, anywhere on a graph:

```

@Diag {
@Graph
  xmin { 0 }
  xmax { 100 }
  ymin { 0 }
  ymax { 100 }
  objects {
    @CTR at { 20 30 } { A:: @Square }
    @CTR at { 60 70 } { B:: @Square }
  }
}
//
@Link from { A } to { B }
}

```

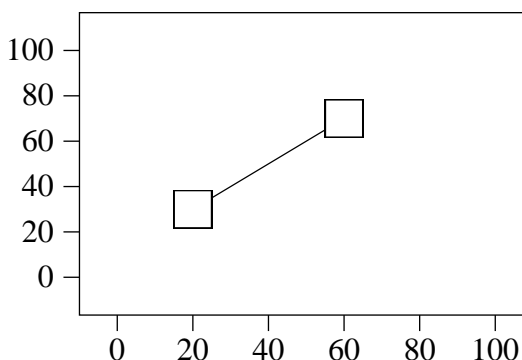

Once again the @Graph symbol occupies the nodes part. You can get rid of the axes by setting the style option of @Graph to none, and then it won't look like a graph at all.

@Diag has a system of node positioning based on coordinates which is somewhat similar to the @Graph one. It is often the easiest way to scatter nodes about a diagram at random. The first step is to create a nodes part that is just an empty space of whatever size you want the final diagram to be:

```

@Diag {
  4c @High 6c @Wide
  //
  ...
}

```

As shown, this is done with the @Wide and @High symbols from basic Lout; the above diagram will be four centimetres high by six centimetres wide.

@Diag has a , symbol that allows you to specify a point by its coordinates in the diagram's base. For example, 0,0 denotes the bottom left-hand corner of the base, 1,0 denotes the bottom right-hand corner, and 0.5,0.5 denotes the centre of the base. Coordinates should usually be between 0 and 1, since otherwise they denote points outside the base (which is allowed but seldom useful).

Every node symbol has a translate option which allows you to move the node about on the diagram's base (or off it if you use coordinates less than 0 or greater than 1). If you use this option, the node effectively has zero size and overstrikes anything else in the area you put it (like labels do). It is best to put these nodes in the links part:

```

@Diag {
@Box margin { 0c } 4c @Wide 5c @High
//
A:: @Square
  translate { CTR to 0.5, 0.67 }
  { @I A }
B:: @Circle
  translate { CTR to 0.8, 0.25 }
  { @I B }
}

```

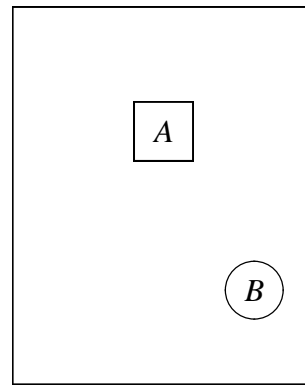

A box with margin zero has been drawn around the empty space to show its extent. The value of `translate` should always be *point to point*; the first point lies within the node, the second lies within the nodes part, and the translation makes these two points coincide.

You are free to have nodes in the nodes part as well, or any object at all. Here is an example which shows what a little ingenuity can accomplish:

```

@Diag {
@Polygon
  sides { 5 }
  outlinestyle { noline }
  hsize { 4c }
  vsize { 4c }
//
A:: @Circle translate { N to P1 } {}
B:: @Circle translate { N to P2 } {}
C:: @Circle translate { N to P3 } {}
D:: @Circle translate { N to P4 } {}
E:: @Circle translate { N to P5 } {}
@Link arrow { both } from { A } to { B }
@Link arrow { both } from { B } to { C }
@Link arrow { both } from { C } to { D }
@Link arrow { both } from { D } to { E }
@Link arrow { both } from { E } to { A }
}

```

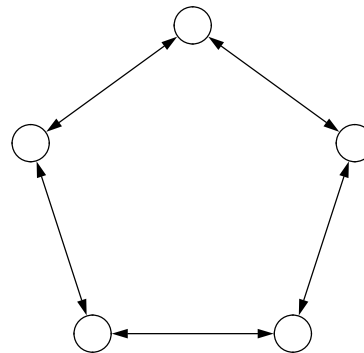

This uses the tags of a phantom polygon to position the real nodes. It would be a rare interactive system that could position nodes with this precision; `@Diag` shines whenever there is a formal positioning rule to follow.

9.7. Trees

`@Diag` offers some symbols for producing tree diagrams, using the `@Tree` symbol, which may appear anywhere within the nodes part:

```
@Diag {
  ...
  @Tree { ... }
  ...
}
```

Within this symbol, new symbols `@LeftSub`, `@RightSub`, `@FirstSub`, `@NextSub`, and `@StubSub` become available. The first two are used to get a (non-empty) binary tree:

```
@Tree {
  @Circle A
  @LeftSub {
    @Circle B
    @LeftSub @Square C
    @RightSub @Square D
  }
  @RightSub @Circle E
}
```

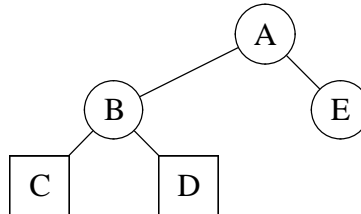

The root of the tree, which must be a single node but may have any outline, comes first. After that comes the `@LeftSub` symbol followed by the left subtree, which must be enclosed in braces unless it consists of a single node. After that comes the `@RightSub` symbol followed by the right subtree, again enclosed in braces unless it consists of a single node. These rules apply recursively and will produce a binary tree of arbitrary size and depth. If a node has no left or right subtree, leave out the corresponding `@LeftSub` or `@RightSub` symbol.

A similar system using `@FirstSub` and `@NextSub` produces trees in which each node may have arbitrarily many children:

```
@Tree {
  @Circle A
  @FirstSub {
    @Circle B
    @FirstSub @Square C
    @NextSub @Square D
  }
  @NextSub @Circle E
  @NextSub @Circle F
}
```

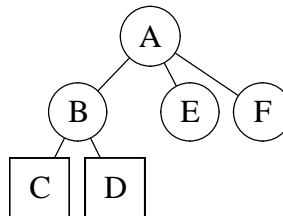

The first subtree is preceded by `@FirstSub`, and subsequent trees are preceded by `@NextSub`. The subtrees are spaced at equal separations from each other, with the root centred over them, in contrast to the binary tree arrangement in which the two subtrees are positioned to the left and right of the root, never intruding into the space beneath it.

Although each subtree must contain a node for its root, it is not hard to get around this:

```

@Tree
{
@Circle
@FirstSub @Circle
@NextSub pathstyle { noline }
  @Circle outlinestyle { noline }
  ...
@NextSub @Circle
}

```

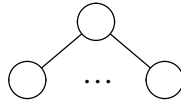

Clumsy as this is, it often assists in placing the unenclosed object in a way consistent with the surrounding nodes, and offers margins and so forth which help with fine-tuning its position.

The fifth subtree symbol, `@StubSub`, produces a stub subtree:

```

@Tree {
@Circle @Math { a }
@StubSub @Math { T tsub a }
}

```



Unlike the other subtree symbols, `@StubSub` is not followed by a subtree with a node for its root; rather, it is followed by an arbitrary object, and the path is drawn around this stub object, which is placed directly underneath the parent node with zero vertical separation. In practice, it is usually necessary to attach margins to the following object; the easiest way to do that is to enclose it in `@Box outlinestyle { noline }`. An example appears below.

It is possible to mix the three subtree types, by having binary tree symbols following some nodes, non-binary tree symbols following others, and a single `@StubSub` following others. However, at any one node the subtrees must be all either binary, non-binary, or stub.

The subtree symbols have all of the options of `@Link`, and these apply to the link drawn from the parent of the root of the subtree to the root of the subtree (or anticlockwise around the stub object):

```

@Tree {
@Circle A
@LeftSub
  arrow { yes }
  xlabel { 1 }
@Circle B
@RightSub
  arrow { yes }
  xlabel { 2 }
@Circle C
}

```

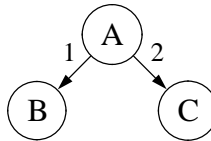

To get reverse arrows use `arrow { back }` as usual.

The subtree symbols do not need from and to options, because they already know which nodes they are linking together. However, you may use from or to to give a tag specifying a

particular point within the node:

```
@Tree {
@Circle
@LeftSub from { S } to { N }
  @Isosceles vsize { 2f }
@RightSub from { S } to { N }
  @Isosceles vsize { 2f }
}
```

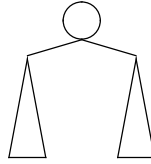

In this example both links go from the S tag of the parent node to the N tag of the child node (at the apex of the isosceles triangle). These options also work for @StubSub, where they refer to the start and end of the stub path:

```
@Tree {
@Circle @Math { a }
@StubSub from { SW } to { SE }
@Box outlinestyle { noline }
  @Math { Tsub a }
}
```

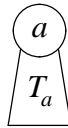

and so the tags both refer to points in the parent node in this case.

The @LeftSub and @RightSub symbols have variants called @ZeroWidthLeftSub and @ZeroWidthRightSub which are the same except that the resulting subtrees consume no width:

```
@Tree {
@Circle
@LeftSub {
  @Circle
  @LeftSub @Square
  @RightSub @Square
}
@RightSub {
  @Circle
  @LeftSub {
    @Circle
    @ZeroWidthLeftSub @Square
    @ZeroWidthRightSub @Square
  }
  @RightSub @Square
}
}}
```

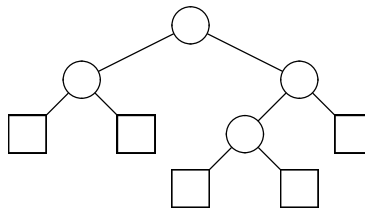

There is nothing analogous for the other subtree symbols.

The @Diag symbol has a few options for adjusting the appearance of the tree. The treehsep option determines the horizontal space left between a root and its left subtree, between a root and its right subtree, and between one subtree and the next when @NextSub is used. The treevsep option determines the vertical space left between a root and its subtrees:

```

@Diag
  treehsep { 0c }
  treevsep { 0c }
{
  @Tree
  {
    @Circle A
    @LeftSub @Square B
    @RightSub @Square C
  }
}

```

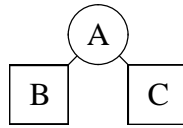

These options may also be given to individual subtree symbols, although `treevsep` works as expected only with `@LeftSub` and `@FirstSub`, since these determine the vertical separation of all children of their parent.

The `treehindent` option determines where the root of a non-binary tree is positioned over its subtrees; the value may be `left` for at left, `ctr` for centred over them (the default), `right` for at the right, or any length, meaning that far from the left. Owing to problems behind the scenes, this option may not be given to individual subtree symbols; so as a consolation, it is permitted as an option to the `@Tree` symbol.

It is not possible to attach tags to nodes within a tree, because tags are attached automatically by the tree symbols and any extra tags would disrupt the linking. However, you can use `@ShowTags` to find out what these automatic tags are, and use them in a subsequent links part. For example, the tag attached to the right child of the left child of the root of a binary tree is `L@R@T`, and in general the tag records the path from the root to the node, with `T` added to the end. The root always has tag `T`. The tree as a whole may be retagged in the usual way.

There is an `@HTree` symbol which is the same as `@Tree` except that the tree grows horizontally (from left to right) instead of vertically. The same symbols are available within `@HTree` as within `@Tree`; `@LeftSub` and `@FirstSub` produce what might be called the top subtree, and `@RightSub` and `@NextSub` produce lower trees. `@HTree` has no `treehindent` option; instead, it has an exactly analogous `treevindent` option.

`@HTree` may be used to get horizontal lists:

```

@! @Diag
  arrow { yes } treehsep { 1c } {
  @HTree {
    @Node A
    @FirstSub {
      @Node B
      @FirstSub @Node C
    }
  }
}

```

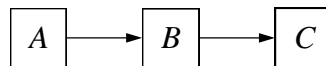

The braces are clumsy but necessary. The first node has tag `T`, the second has tag `S@T`, the third has tag `S@S@T`, and so on.

9.8. Syntax diagrams

A variant of the @Diag symbol, called @SyntaxDiag, produces syntax diagrams (sometimes called railroad diagrams):

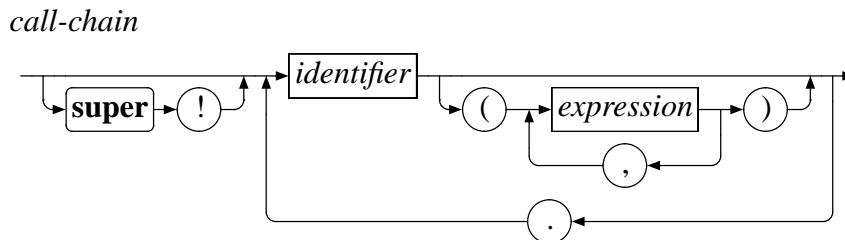

These are used to define the syntax of computer programming languages, although they could be put to other uses. We'll explain how to get syntax diagrams first. At the end of this section is an explanation of how to change the formats of things, which people who use these diagrams for other purposes will probably need to do.

A syntax diagram can be *right-moving*, which means it starts at the left and heads right (like the example above), or it can be *down-moving*, starting at the top and heading downwards. The @StartRight and @StartDown symbols are used at the start of the diagram to say which of these directions is wanted:

```
@SyntaxDiag
  title { call-chain }
{
  @StartRight ...
}
```

where ... stands for the rest of the diagram, as we are about to describe. For completeness there are also @StartLeft and @StartUp symbols, but diagrams never start off in these directions.

If you accidentally omit the starting symbol (@StartRight or whatever), you will get several error messages, the first of which should mention diag_dirn; it is trying to tell you, in a cryptic way, that it doesn't know which direction you want to go in.

The title option is optional; if given, the effect is as shown (this option is also available with @Diag). Subsequent examples will omit the enclosing @SyntaxDiag { ... }.

The basic components of syntax diagrams are *category cells*, shown as boxes in the example above and obtained with the @ACell symbol; *keyword cells*, shown as curved boxes and obtained with @BCell; and *punctuation cells*, containing punctuation symbols small enough to be enclosed in circles, and obtained with @CCell. After each symbol, place whatever has to go inside the cell:

```
@StartRight @BCell loop → loop →
```

Lout will insert the appropriate arrows, taking account of which direction (right, up, left, or down) the diagram is currently moving. This is true for all the syntax diagram symbols; we won't mention it again.

Occasionally, instead of a cell one wants the horizontal or vertical line to continue

uninterrupted. For this there is the @Skip symbol:

@StartDown @Skip
↓

Some examples of its use in practice appear below.

There are three main ways to build up larger syntax diagrams out of smaller ones: *sequencing*, *selection*, and *looping*. For sequencing there is the @Sequence symbol:

@StartRight @Sequence → **loop** → *statements* → **end** →
 A { @BCell loop }
 B { @ACell statements }
 C { @BCell end }

This is what the sequence looks like in the other three directions:

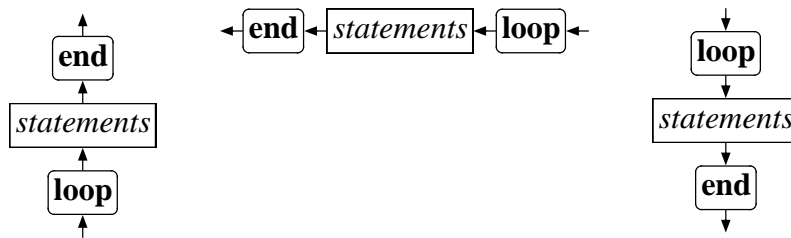

Whatever the direction, the arrows go from option A to option B to option C and so on. You can have up to twelve items in the sequence, in options A to L; if more than twelve are needed, just place another sequence inside any one of these options: where one syntax diagram is allowed, any syntax diagram is allowed, provided there is enough space on the page (Lout makes a total mess of any diagram that is too wide to fit on the page).

After sequencing comes selection, which is obtained with the @Select symbol:

@StartRight @Select → **asst** →
 A { @ACell asst } → **call-chain** →
 B { @ACell call-chain } → **assert** → **condition** →
 C { @Sequence
 A { @BCell assert }
 B { @ACell condition }
 }
 }

This example shows right-moving selection of three alternatives, the third being a sequence of things. Here is the same example in the other three directions:

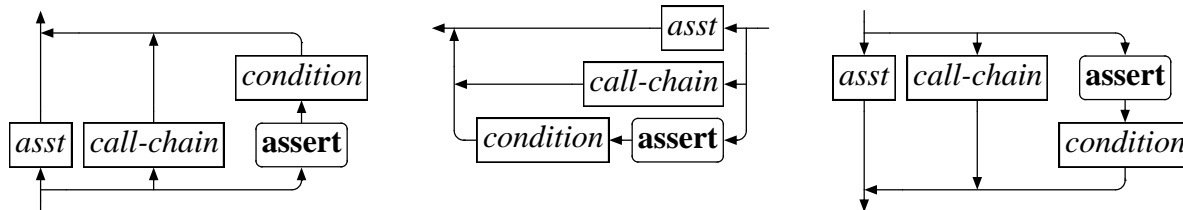

When building up complex diagrams like this, it pays to keep the indenting perfect in the source

document. As with sequences, there can be up to twelve alternatives, in options from A to L.

To say that something is *optional* is to select either that thing or nothing:

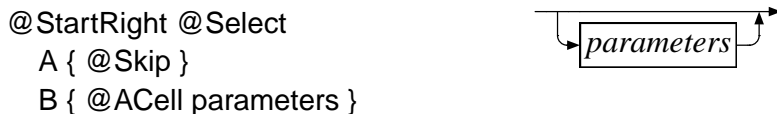

Since this case is so common, there is an @Optional symbol for it:



@Optional is exactly like @Select with option A set to @Skip and option B set to the syntax diagram following the @Optional symbol. Here is the same example in the other three directions:

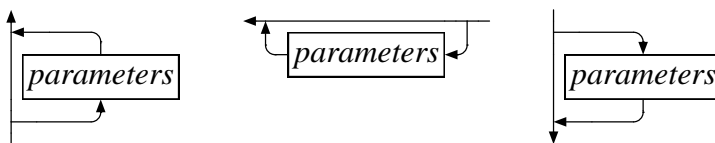

There is another kind of ‘optional’ layout, @OptionalDiverted:

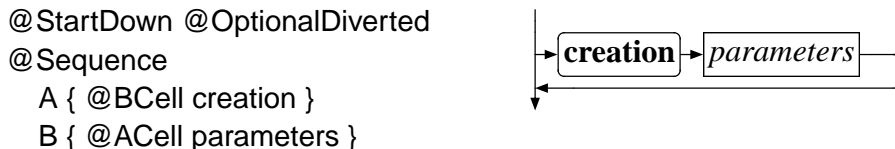

Here is the same example in the other three directions:

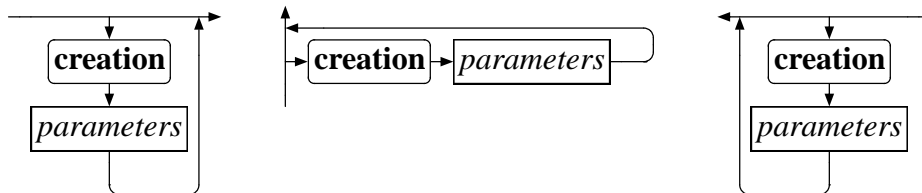

The optional material goes in a direction perpendicular to what it would have otherwise: right-moving if previously up or down, and down-moving if previously left or right.

Another, related symbol is @Diverted; it is similar to @OptionalDiverted but without the path which produces nothing:

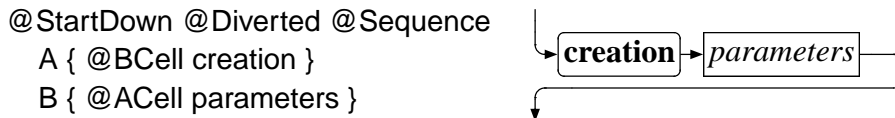

Here is the same example in the other three directions:

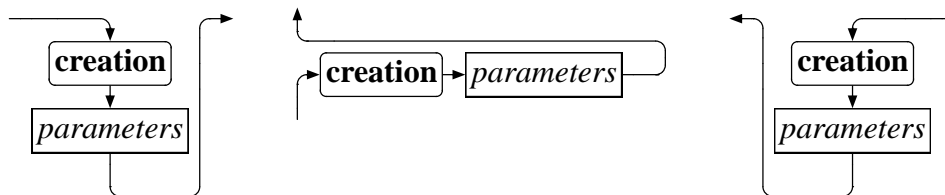

This symbol is a great aid to packing a big syntax diagram into a compact shape.

A variant of the basic selection idea is when you want one thing or another, or alternatively both in a particular order. You can get this with the @OneOrBoth symbol, which takes exactly two options, A and B:

```
@StartRight @OneOrBoth
A { @ACell type }
B { @ACell body }
```

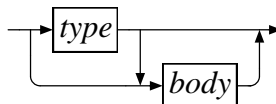

Although the concept extends to more than two options, the symbol doesn't. The summary at the end of this chapter shows the other three directions.

That covers sequencing and selection; now for looping. The @Loop symbol produces a loop, with option A going forwards and option B centred and going backwards:

```
@StartRight @Loop
A { @Sequence
  A { @ACell identifier }
  B { @CCell : }
  C { @ACell type }
}
B { @CCell , }
```

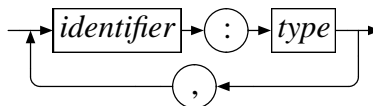

Here is the same example in the other three directions:

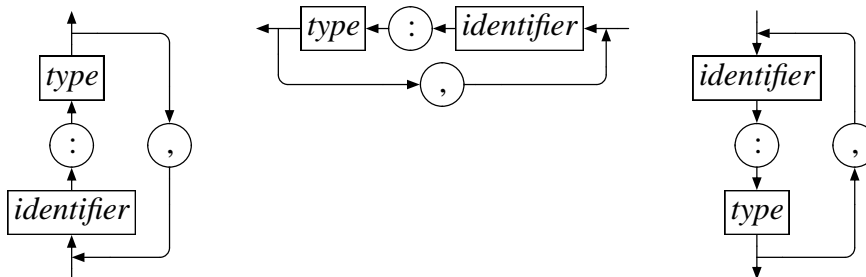

One common case of looping is to have nothing on the way back. We could get this by placing @Skip in option B of @Loop, but there is an even easier way, the @Repeat symbol:

```
@StartRight @Repeat
@ACell statement
```

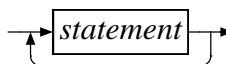

Here is the same example in the other three directions:

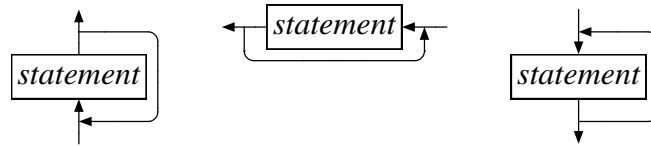

Occasionally it looks better to have the empty returning arrow go on the opposite side of the forward part; for that, there are @LoopOpposite and @RepeatOpposite symbols:

```

@StartRight @LoopOpposite
A { @Sequence
  A { @ACell identifier }
  B { @CCell : }
  C { @ACell type }
}
B { @CCell , }
    
```

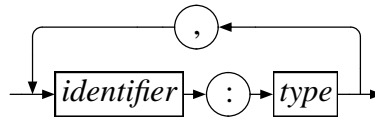

Here is the same example in the other three directions:

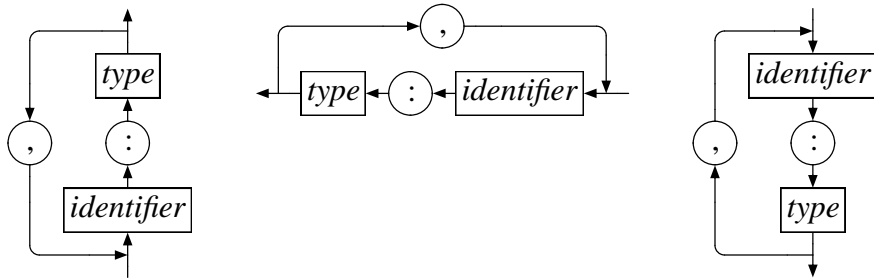

@RepeatOpposite is particularly useful around a large @Select:

```

@StartRight @RepeatOpposite
@Select
A { @ACell asst }
B { @ACell call-chain }
C { @BCell return }
D { @Sequence
  A { @BCell assert }
  B { @ACell condition }
}
E { @ACell conditional }
F { @ACell selection }
G { @ACell loop }
    
```

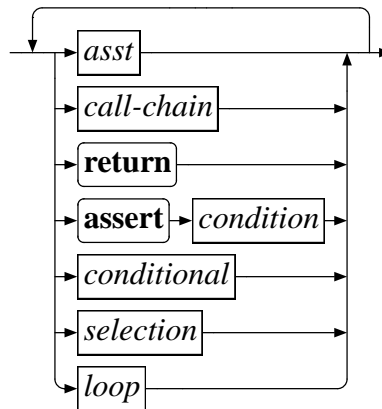

since it clearly distinguishes the loop from the selection.

Finally, the @RepeatDiverted symbol combines the two ideas of repetition and diversion:

```

@StartDown @RepeatDiverted
@ACell statement
    
```

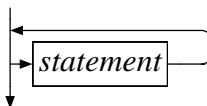

Here is the same example in the other three directions:

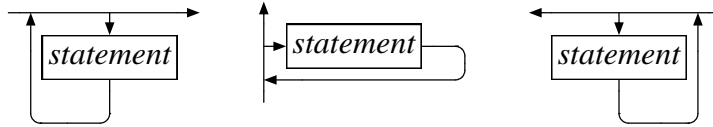

There is no `@LoopDiverted` symbol, for good reason.

Every syntax diagram, from the simplest to the most complex, has one arrow going into it, and one coming out. There are no exceptions to this rule. In most syntax diagrams, these two arrows lie on the same (invisible) line and point in the same direction, and this is the direction that we say the diagram is moving. There are two symbols that produce syntax diagrams that lack this second property. Because of this lack, these symbols cannot be used at arbitrary places in a complex diagram; they can only be used instead of the `@StartRight` or `@StartDown` symbols at the beginning of a diagram. The first symbol, `@StartRightDown`, prints its option A right-moving and its option B down-moving like this:

```
@StartRightDown
A { @ACell A }
B { @ACell B }
```

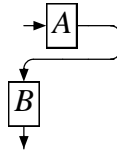

The second symbol, `@StartRightRight`, prints both options right-moving like this:

```
@StartRightRight
A { @ACell A }
B { @ACell B }
```

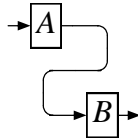

As usual, the options to these symbols may contain arbitrarily complex syntax diagrams.

Finally, a few words about changing things. The `@SyntaxDiag` symbol used the `@ANode`, `@BNode`, and `@CNode` symbols of `@Diag` to construct its three types of cells. In fact, the `@SyntaxDiag` symbol is nothing more than this:

```

@Diag
  align { mark }
  avstrut { yes }
  amargin { 0.2f }
  aoutline { box }
  afont { Italic }
  balign { mark }
  bvstrut { yes }
  bmargin { 0.2f }
  boutline { curvebox }
  bfont { Bold }
  calign { mark }
  cvstrut { yes }
  cmargin { 0.2f }
  coutline { circle }
  chsize { 1f }
  arrowlength { 0.4f }

```

So any of the other @Diag options can be used freely with @SyntaxDiag; and the format of the three cell types can be changed by using @Diag instead of @SyntaxDiag, and choosing new values for these (and other) options. For example, if you need four or five types of cell, just set some d and e options and use @DCell and @ECell in addition to @ACell, @BCell, and @CCell.

If there are more than five cell types, it is necessary to fall back on the @XCell symbol, which produces a cell without nominating any particular cell type. After @XCell there must be a regular @Diag node, like this:

```

@StartRight @XCell @Ellipse INIT → (INIT) →

```

This way there is no limit to the number of different kinds of cells. Also, since (for example) @ACell is merely an abbreviation for

```
@XCell @ANode
```

any node options may follow @ACell, @BCell, @CCell, @DCell, and @ECell. The appearance of the arrows can be changed in the usual way, by setting options as has been done above for arrowlength.

There are three options specifically related to syntax diagrams:

```

@SyntaxDiag
  syntaxgap { 0.35f }
  syntaxbias { 1.0f }
  syntaxradius { 0.3f }

```

The syntaxgap option determines the spacing between the various elements; changing it causes the syntax diagrams to be set tighter or looser in a consistent way. The default value shown is 0.35 times the current font size. The syntaxbias and syntaxradius options affect the appearance of curved lines, as in @RVLCurve and its relatives. These options are also available with @Diag,

and in the setup file. Note however that these options cannot be given to individual elements in a syntax diagram, only to the diagram as a whole.

9.9. Errors

Lout normally produces an output file that will print without mishap on any PostScript device. However, some of the options of `@Diag`'s symbols are passed through Lout to the output file without checking, including anything containing `@Diag` lengths, angles, points, and tags. Any errors in these options will not be detected until the file is printed.

The most likely errors are *syntax errors*, as in `outline { 0 0 [0 xsize } for example, in which a]` is missing; *type errors*, as in `SE:: 45d` where the following object should have been a point; and *undefined errors*, arising from labels misspelt or used before being defined. Less commonly, the options may all be correct but the figure is too large in some way: too many labels, too deeply nested, and so on.

When an error is detected, `@Diag` arranges for the offending page to be printed up to the point where the error occurred, with a message nearby describing the error. Printing of the document is then aborted. It is often quite easy to find the problem, because it lies in whatever should have been printed next.

If you see `VMerror` in an error message, it means that the printer is running out of memory. In that case, one thing you can try is

```
@Diag
  save { yes }
...
```

This causes the memory used by `@Diag` to be reclaimed as soon as the diagram is printed, rather than at the end of the current page as is usual. However, if the diagram is nested inside some other major Lout package, such as `@Graph`, use of this option may cause other PostScript errors.

If you see `dictfull` in an error message, it means that you are using an old version of PostScript. Increasing the `maxlabels` option of `@Diag` (Section 9.12) might fix the problem.

On other occasions your document might print without problems but you see things that should not be there. Here is a typical example, reported by a user:

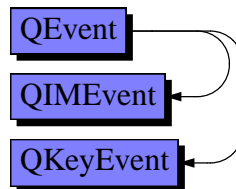

The problem here is the two short lengths of straight line protruding backwards beyond the point where the arrow starts to curve. This has occurred because the TO labels are to the right of the point where the curving begins; it can be corrected either by reducing the `radius` option, or else by decreasing `zindent`. Ideally `@Diag` would adjust options for you so as to ensure that the diagram always look good; but this is quite difficult to do, especially when space to turn in is tight or there is a choice of which option to adjust, as in the example above. So `@Diag` just does a few basic

things and leaves the rest to you.

9.10. Expert usage: defining new shapes

@Diag permits you to create your own node outlines and link paths, by giving non-standard values to the outline and path options. This section shows how to do this for very simple shapes only; the following section introduces the large repertoire of geometrical symbols that @Diag offers for helping you create complex shapes.

As explained earlier, a node outline is drawn over its *base*, which is a rectangle containing the following object plus margins. The base defines a coordinate system with the point (0, 0) at the bottom left corner, and (*xsize*, *ysize*) at the top right:

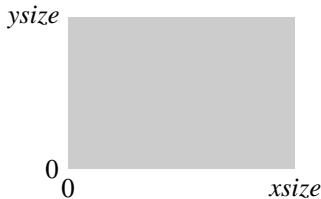

The value of the outline option is a sequence of points defined in this coordinate system:

```
@Node
outline {
  0 0
  xsize 0
  0 ysize
  0 0
}
```

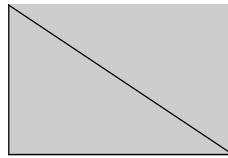

As shown, the resulting outline is created by joining each point to the next with a straight line. It is conventional to proceed anticlockwise around the outline, but you may start anywhere.

The paint, texture, *outlinestyle*, *outlinedashlength*, and *outlinewidth* options of @Node work for user-defined outlines exactly as they do for the standard ones:

```
@Node
outline {
  0 0
  xsize 0
  0 ysize
  0 0
}
paint { lightgrey }
outlinestyle { solid dashed }
```

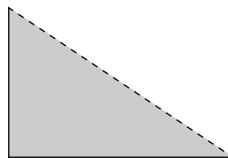

Each line in the outline is one segment for *outlinestyle*.

If two points in an outline are separated by [], no line is drawn between them, and the outline is treated as two separate, disconnected regions when painting.

Two points may also be separated by `[point]`, where *point* stands for any point. This causes the two points to be joined by an arc whose centre is at the given point:

```
@Node
outline {
  0 0
  ysize 0
  [ 0 0 ]
  0 ysize
  0 0
}
```

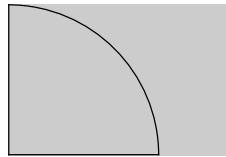

The arc will be circular if possible, otherwise it will be part of an ellipse whose axes are oriented horizontally and vertically. The arc goes anticlockwise; to get a clockwise arc, use `[point clockwise]`.

Two points may be separated by `[x1 y1 x2 y2]`, which requests that a Bezier curve be drawn between them with control points (x_1, y_1) and (x_2, y_2) :

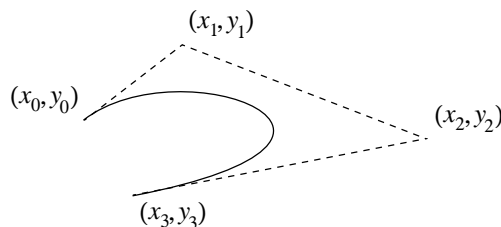

The curve is attracted toward the control points, without reaching them; it is tangent to the straight line from the start point to the first control point, and from the second control point to the finishing point, and it lies wholly inside the quadrilateral formed by the four points. Owing to the author's laziness, dashes and dots do not fit as neatly onto Bezier curves as they do onto lines and arcs.

Tags (Section 9.4) may be assigned to points within the outline option, like this:

```
@Node
outline {
  LR:: { xsize 0 }
  UL:: { 0 ysize }
  0 0 LR UL 0 0
}
```

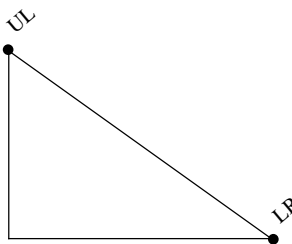

The tagged point does not have to lie on the outline, and it is not automatically added to the outline. Once defined, a tag stands for a point in the usual way; it may be used later in the outline, as was done above, relabelled, and so on, exactly like the tags of the standard nodes.

Once a point has been tagged, a *direction* may be associated with it, to inform `@Diag` which way the outline or link path is going at that point. The standard outlines have directions:

```
@Ellipse { 3c @Wide 1c @High }
```

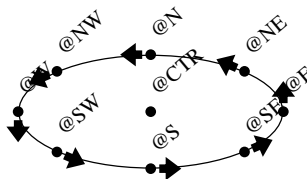

CTR has no direction. If available, direction information is used when placing labels, in the proximity step (by above, for example) and in the angle step if the label is aligned, perpendicular, parallel, or antiparallel. A direction is given using the :< symbol within an outline:

```
@Node
outline {
  LR:: { xsize 0 }
  LR:< 0d
  UL:: { 0 ysize }
  UL:< 270d
  0 0 LR UL 0 0
}
```

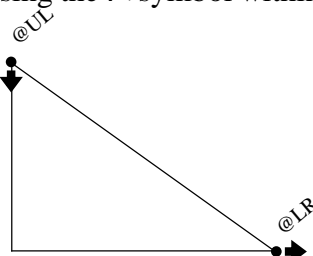

It is often helpful when creating outlines to check where the tagged points and directions really are, by printing them out as is done above. For this there is a @ShowTags symbol whose result is the following (arbitrary) object with its tagged points visible, and a @ShowDirections symbol which works similarly and shows the directions. The diagram above was printed using @ShowTags @ShowDirections @Node ... There is also a @ShowPoints symbol which is like @ShowTags except that it omits the tags, just placing circles on the points.

Link paths are similar to node outlines, created using the path option of @Link instead of the outline option of @Node. The major difference is that links have no base, so xsize and ysize cannot be used. Indeed, even 0 0 does not have any useful meaning inside a link path.

Within a link path, the symbols from and to denote the values of the link's from and to options, and these form the basis of constructing the link path:

```
@Link
path {
  FROM:: from
  TO:: to
  FROM TO
}
```

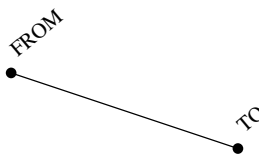

This simple example creates two tagged points and joins them with a straight line. If you want a link that can carry arrowheads, it is best to ensure that it creates FROM and TO tags, with directions pointing along the link from FROM to TO at both points, since then the default values of the various arrow options will do the rest. Similarly, if you want labels you need to define LFROM, LMID, and LTO labels, ideally also with directions.

Once the outline or path is complete, unless it is really a one-off production the best thing to do with it is to add it to your mydefs file in the following form:

```

extend @DiagSetup @Diag
macro @MyNode {
  @Node
  outline {
    LR:: { xsize 0 }
    LR:< 0d
    UL:: { 0 ysize }
    UL:< 270d
    0 0 LR UL 0 0
  }
}

```

This says that we are ‘extending’ the @Diag symbol by adding a new symbol, @MyNode, which stands for what follows it between braces. @MyNode will then behave exactly like @Circle and the other standard node symbols. The same pattern works for links:

```

extend @DiagSetup @Diag
macro @MyLink {
  @Link
  path {
    FROM:: from
    TO:: to
    FROM TO
  }
}

```

If it is worth the effort to construct a new outline or link path, it is worth packaging it like this and thinking up a good name for it, for then it will be available, easily, forever.

This same approach is also useful to define common combinations of options, even when there is no new outline or path:

```

extend @DiagSetup @Diag
macro @BigOctagon {
  @Polygon
  sides { 8 }
  hsize { 5c }
  vsize { 5c }
  font { Bold }
}

```

Such definitions are very useful if the combinations occur frequently. Any options not mentioned have their usual default values, and may be set in the usual way:

```
@BigOctagon outlinestyle { dashed } ...
```

Attempts to reset an already set option will elicit a warning message.

9.11. Expert usage: numbers, lengths, angles, and points

@Diag has many options whose values contain lengths, angles, and points. Options such as `margin` and `vsize`, which affect the size or appearance of the base of a node, may contain only the kinds of lengths described in Section 1.2; but in all other cases arbitrarily complex algebraic expressions may be used to specify the values.

The usual mathematical operations may be applied to numbers, angles, and lengths:

```
2.0f + 3.0f * sin { 30d }
```

is a valid length. Since this is just ordinary algebra on real numbers, the unsurprising details are deferred to the summary (Section 9.12). Grouping is always done with braces, never parentheses.

More interesting are the geometrical symbols that @Diag provides. The most fundamental is not a symbol at all: two lengths side by side define a point. For example,

```
xsize ysize * 0.5
```

within an outline is the point at the far right of the base, halfway up.

There are `++` and `--` symbols for vector addition and subtraction of two points, and `**` for multiplication by a scalar. For example,

```
A@CTR ++ { 1.0f 0 }
```

is the point 1f to the right of A@CTR. It is a good idea to distinguish between *absolute points*, like A@CTR and 0.5,1, which denote fixed positions on the page, and *relative points*, like 1.0f 0, which serve as offsets from absolute points. The difference of two absolute points is a relative point; adding two absolute points gives an unpredictable result because it depends on the origin of the coordinate system. However, the expression

```
P1 ** x ++ P2 ** {1 - x}
```

is safe for any two absolute points P1 and P2 and any number x; it produces a point on the line through the two points.

These remarks on safety do not apply within the outline option of @Node, because there the coordinate system is clearly specified. Vector operations, with the aid of a few well-chosen tags, can greatly simplify the production of outlines:

```

@Node
outline {
  SB:: {0 ysize} ** 0.4
  ST:: {0 ysize} ** 0.6
  HB:: {xsize 0} ** 0.7
  SB
  SB ++ HB
  HB
  xsize ysize * 0.5
  HB ++ {0 ysize}
  HB ++ ST
  ST
  SB
}
paint { grey }
{ 6c @Wide 2c @High }

```



But absolute sums like `SB ++ HB` are not safe in link paths and stray options like `alabelpos`.

Sometimes it is useful to define tags which are not wanted afterwards and are better forgotten. For this there is the `:=` symbol, which works in much the same way as `::` except that the tag is forgotten after the outline or path option ends. The value assigned does not have to be a point, it can be a length or angle, or even a sequence of values. It is permissible to change the value assigned to a tag by reassigning.

Two very useful symbols, `angleto` and `atangle`, bring angles into the algebra. The `angleto` symbol finds the angle from one point to another. For example,

```
SB angleto ST
```

in the outline above would produce `90d`. The `atangle` symbol finds the point at a given length and angle from the origin. For example,

```
1.4142f atangle 45d
```

is the point `1f 1f`, and

```
B@NE ++ 2f atangle 115d
```

is the point `2f` from `B@NE` to its northwest.

There is a `prev` symbol, used only within `outline` and `path`, which returns the previous point on the outline or path, ignoring points within `[]`. It makes relative movements very easy:

```
outline {
  0 0
  { 2c atangle 30d }
  prev ++ { 2c atangle 90d }
  prev ++ { 2c atangle 150d }
  prev ++ { 2c atangle 210d }
  prev ++ { 2c atangle 270d }
  0 0
}
```

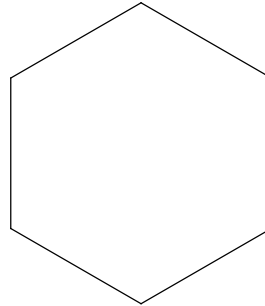

This example is rather naughty because the outline does not grow and shrink with the base as it should. Such outlines, while tempting, are always regretted later.

There are `xcoord` and `ycoord` symbols for finding the x and y coordinates of a point:

```
{xcoord P1} min {xcoord P2} {ycoord P1} max {ycoord P2}
```

is the point at the top left-hand corner of the smallest rectangle containing points `P1` and `P2`. And there is a distance symbol which produces the (non-negative) distance between two points:

```
CTR ++ { CTR distance NW } atangle { CTR angleto NW }
```

equals `NW`.

The rest of this section is concerned with how the ‘special virtue’ of the `from` and `to` options, their ability to accept a node tag as well as a point, is implemented behind the scenes. A good user-defined link should also have this virtue, because it is extremely useful.

The solution is based on a symbol called `boundaryatangle`, whose preceding object should be either a point or else the tag of a node with one of the standard shapes, and whose following object is an angle:

```
{ xsize ysize*0.5 } boundaryatangle 45d
A boundaryatangle 45d
```

In the first case the result is the point, regardless of the angle. In the second case, the result is the point on the boundary of the node whose tag is given, at the given angle from the centre.

There is a second symbol with a similar adaptive ability, called `??`, which is defined to be `@` whenever that would make sense, and otherwise to produce the preceding object for its result. For example, `A??CTR` will equal `A@CTR` if there is such a thing; but

```
{ xsize ysize*0.5 }??CTR
```

will have result `{ xsize ysize*0.5 }` since replacing `??` by `@` does not produce anything sensible.

Now suppose we want a link path that connects `from` and `to` by a straight line, where `from` and `to` may be either node tags or points. In either case a suitable direction for the line to take is

```
from??CTR angleto to??CTR
```

and so the desired path is

```

path {
  FROM:: from boundaryatangle { from??CTR angleto to??CTR }
  TO:: to boundaryatangle { to??CTR angleto from??CTR }
  FROM
  TO
}

```

The first line defines point FROM to be on the boundary of from at the appropriate angle, if from is a node tag; otherwise FROM is just the point from. The second line defines point TO similarly, and then the last two lines join these two points. The line standard link type is exactly this plus a few additional tags and directions.

9.12. Summary

Here is the complete list of standard node outlines that may be given to the @Node symbol. Each shows the outline name, any extra options relevant to this outline, base (shown as a grey box), segments (shown using `outlinestyle { solid dashed }`), tags, and directions (shown as a thick arrowhead wherever defined):

```
@Node
outline { box }
```

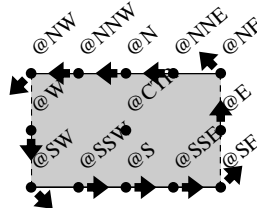

```
@Node
outline { curvebox }
```

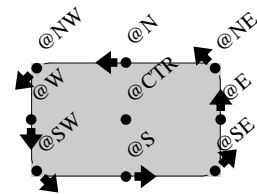

```
@Node
outline { shadowbox }
shadow { 0.4f }
```

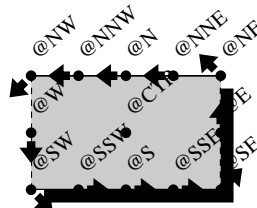

```
@Node
outline { square }
```

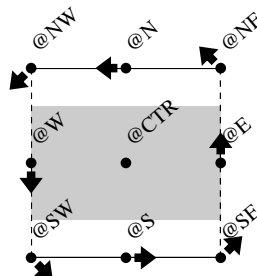

@Node
outline { diamond }

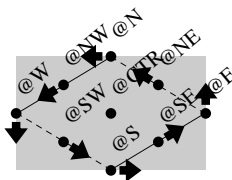

@Node
outline { polygon }
sides { 3 }
angle { 180d / sides }

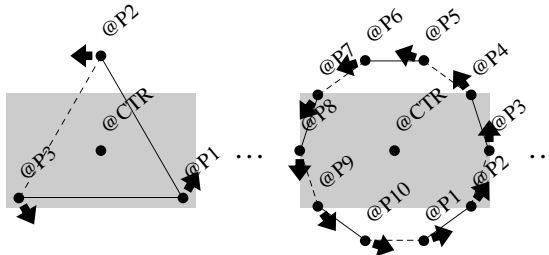

@Node
outline { isosceles }

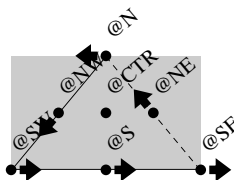

@Node
outline { ellipse }

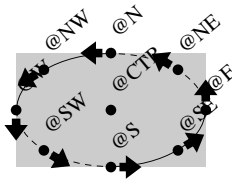

@Node
outline { circle }

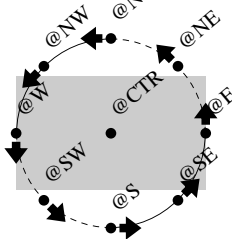

Here are the abbreviations for the standard shapes:

- | | |
|-----------------------|------------|
| outline { box } | @Box |
| outline { curvebox } | @CurveBox |
| outline { shadowbox } | @ShadowBox |
| outline { square } | @Square |
| outline { diamond } | @Diamond |
| outline { polygon } | @Polygon |
| outline { isosceles } | @Isosceles |
| outline { ellipse } | @Ellipse |
| outline { circle } | @Circle |

Here are all the options to the @Node symbol, their default values, and their ranges of allowed values. Definitions of *number*, *length*, *angle*, and *point* appear later in this summary. The options related to *alabel*, *blabel*, *clabel*, and *dlabel* have mostly been omitted since they are the same as the *nodelabel* options except for *nodelabelpos*.

@Node			
outline	{ box }		box, curvebox, shadowbox, square, diamond, polygon, ellipse, circle, or any outline
margin	{ 0.6f }		any length from Section 1.2
shadow	{ 0.4f }		any <i>length</i>
sides	{ 3 }		any <i>number</i> (it will be rounded to the nearest integer)
angle	{ 180d / sides }		any <i>angle</i>
translate	{ }		empty, or <i>point</i> to <i>point</i>
outlinestyle	{ solid }		solid, dashed, cdashed, dotted, dotdashed, dotcdashed, dotdotdashed, dotdotcdashed, dotdotdotdashed, dotdotdotcdashed, noline, or any sequence of one or more of these values
outlinedashlength	{ 0.2f }		any <i>length</i>
outlinewidth	{ thin }		thin, medium, thick, or any <i>length</i>
paint	{ none }		none or any colour from Section 8.1
texture	{ solid }		Any texture from Section 8.2
font	{ }		any value suitable for the @Font symbol
break	{ }		any value suitable for the @Break symbol
format	{ @Body }		any object, usually containing @Body
valign	{ ctr }		top, ctr, foot, or any length from Section 1.2
vsize	{ }		empty, or any length from Section 1.2
vindent	{ ctr }		top, ctr, mctr, foot, or any length from Section 1.2
vstrut	{ no }		no, yes, or any length from Section 1.2
vmargin	{ margin }		any length from Section 1.2
topmargin	{ vmargin }		any length from Section 1.2
footmargin	{ vmargin }		any length from Section 1.2
halign	{ ctr }		left, ctr, right, or any length from Section 1.2
hsize	{ }		empty, or any length from Section 1.2
hindent	{ ctr }		left, ctr, mctr, right, or any length from Section 1.2
hstrut	{ no }		no, yes, or any length from Section 1.2
hmargin	{ margin }		any length from Section 1.2
leftmargin	{ hmargin }		any length from Section 1.2
rightmargin	{ hmargin }		any length from Section 1.2
nodelabel	{ }		any object
nodelabelmargin	{ 0.2f }		any length from Section 1.2
nodelabelfont	{ -2p }		any value suitable for the @Font symbol
nodelabelbreak	{ ragged nohyphen }		any value suitable for the @Break symbol
nodelabelformat	{ @Body }		any object, usually containing @Body
nodelabelpos	{ }		any <i>point</i>
nodelabelangle	{ horizontal }		horizontal, aligned, or perpendicular; parallel, antiparallel, or any <i>angle</i>

nodelabelprox	{ outside	}	above, below, left, right, inside, or outside; CTR, N, S, E, W, NE, NW, SW, SE, NNW, NNE, SSW, or SSE
nodelabelctr	{ no	}	yes or no
nodelabeladjust	{ 0 0	}	any <i>point</i>
alabelpos	{ NE	}	any <i>point</i>
blabelpos	{ NW	}	any <i>point</i>
clabelpos	{ SW	}	any <i>point</i>
dlabelpos	{ SE	}	any <i>point</i>

Here is the complete list of standard link paths that may be given to the @Link symbol. Each entry shows the link path name, any extra options relevant to this path, segments (shown using `outlinestyle { solid dashed }`), and tags. All tags have directions pointing along the link from FROM to TO; these have been omitted for clarity. The `frompt` and `topt` options of `bezier` are compulsory and denote the two control points (Section 9.10).

@Link
path { line }

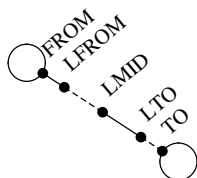

@Link
path { doubleline }

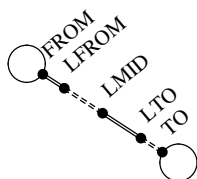

@Link
path { curve }
bias { 2.0f }

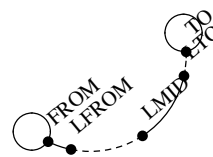
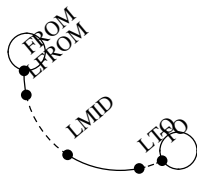

@Link
path { ccurve }
bias { 2.0f }

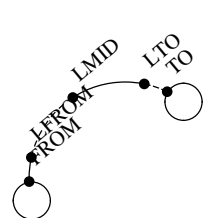
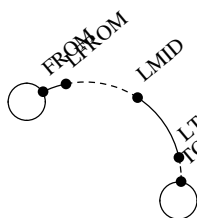

@Link
path { bezier }
frompt { A@CTR ++ { 3f 0 } }
topt { B@CTR ++ { 3f 0 } }

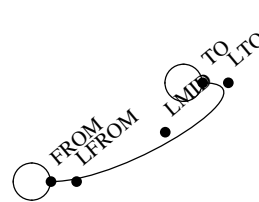
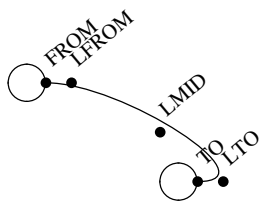

@Link
path { vline }

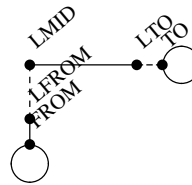
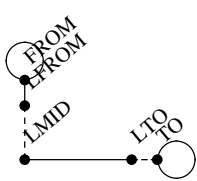

@Link
path { hvline }

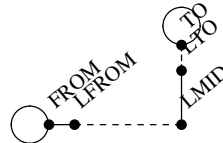
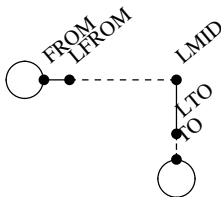

In the following links, the radius option determines the radius of the curved corners of the link.

@Link
path { vcurve }
radius { 1.0f }

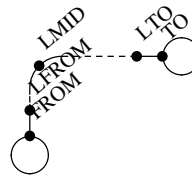
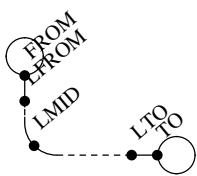

@Link
path { hvcurve }
radius { 1.0f }

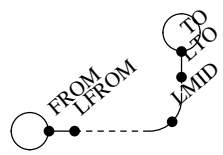
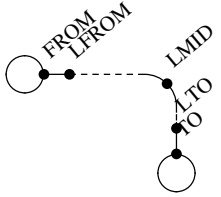

In the following links, the bias option determines how far the link extends to the left of the leftmost node, or to the right of the rightmost node.

@Link
path { lvrline }
bias { 2.0f }

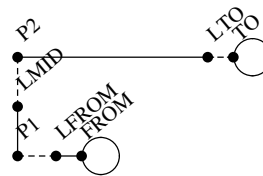
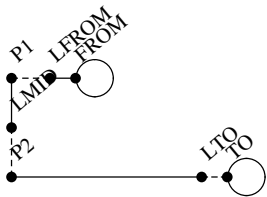

@Link
path { rvlline }
bias { 2.0f }

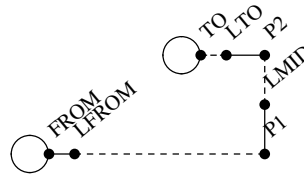
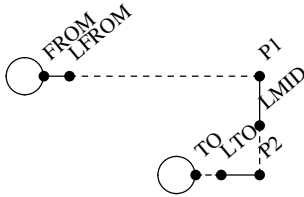

@Link
 path { lvrcurve }
 bias { 2.0f }
 radius { 1.0f }

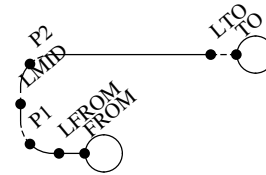
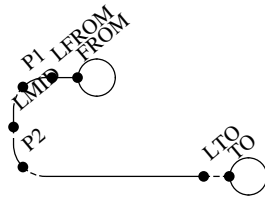

@Link
 path { rvlcurve }
 bias { 2.0f }
 radius { 1.0f }

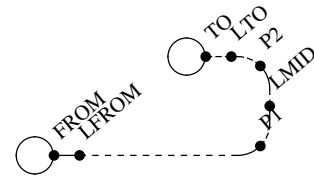
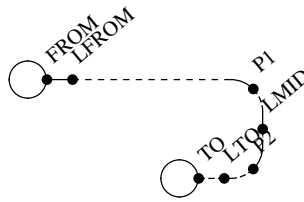

@Link
 path { dhuline }
 bias { 2.0f }

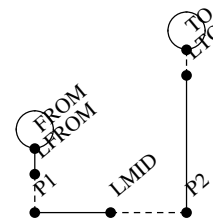
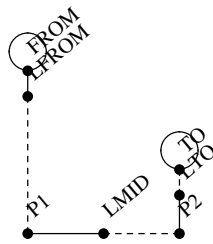

@Link
 path { uhdline }
 bias { 2.0f }

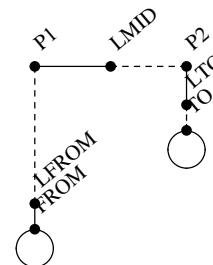
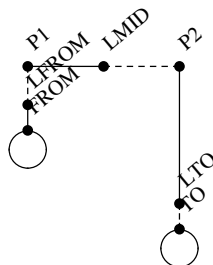

@Link
 path { dhucurve }
 bias { 2.0f }
 radius { 1.0f }

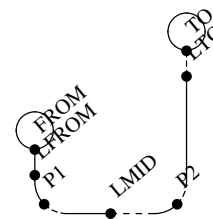
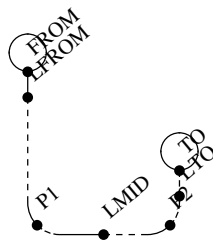

@Link
 path { uhdcurve }
 bias { 2.0f }
 radius { 1.0f }

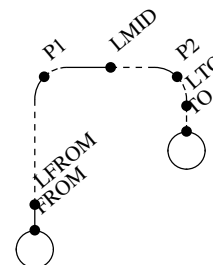
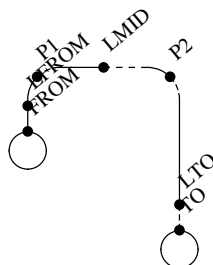

In the following links, the hfrac and hbias options determine how far across from FROM to TO the path turns vertical: a fraction hfrac of the way across, plus a distance hbias. The default settings shown make this point halfway; by changing hfrac to 0 and giving a length to hbias, one can select a particular distance, rather than a fraction of the total distance.

```
@Link
path { hvhline }
hfrac { 0.5 }
hbias { 0f }
radius { 1.0f }
```

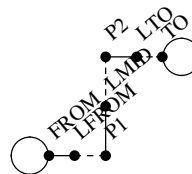
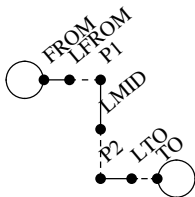

```
@Link
path { hvhcurve }
hfrac { 0.5 }
hbias { 0f }
radius { 1.0f }
```

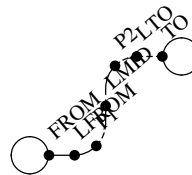
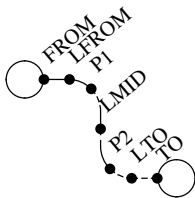

```
@Link
path { vvhline }
hfrac { 0.5 }
hbias { 0f }
radius { 1.0f }
```

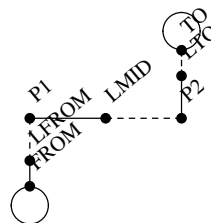
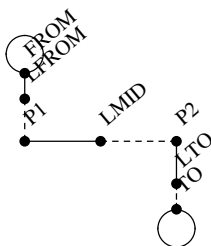

```
@Link
path { vvhcurve }
hfrac { 0.5 }
hbias { 0f }
radius { 1.0f }
```

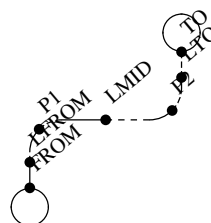
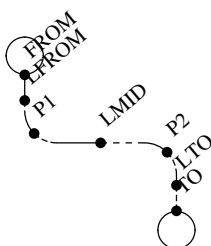

In the following links, the fbias option determines how far the curve extends away from the FROM node; the tbias option determines how far it extends away from the TO node; and the bias option determines how far it extends above the higher or below the lower node.

```
@Link
path { dwrapline }
tbias { 2.0f }
bias { 2.0f }
fbias { 2.0f }
```

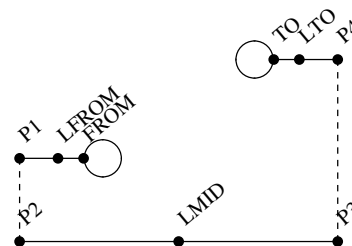
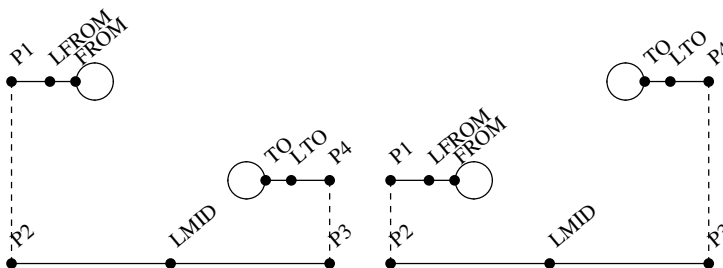

```
@Link
path { unwrapline }
tbias { 2.0f }
bias { 2.0f }
fbias { 2.0f }
```

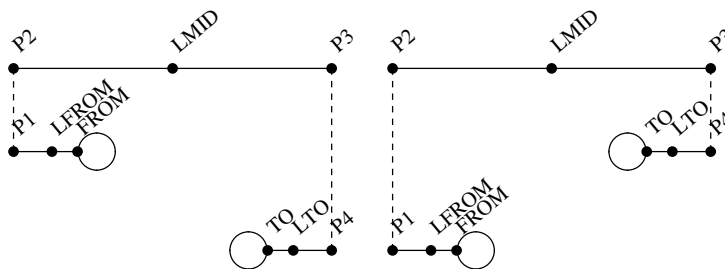

```
@Link
path { dwrapcurve }
tbias { 2.0f }
bias { 2.0f }
fbias { 2.0f }
radius { 1.0f }
```

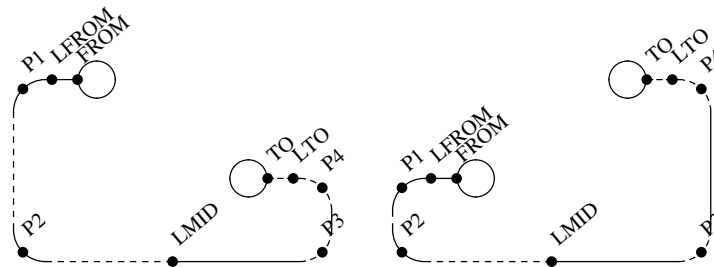

```
@Link
path { unwrapcurve }
tbias { 2.0f }
bias { 2.0f }
fbias { 2.0f }
radius { 1.0f }
```

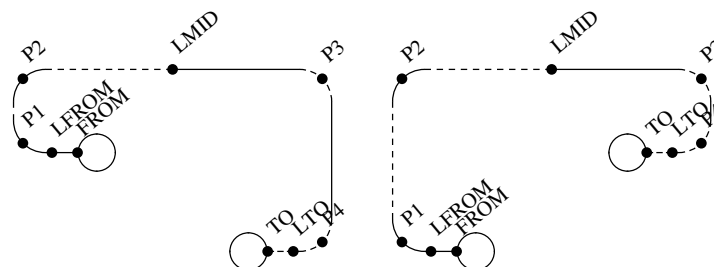

Here is the list of abbreviations for the standard paths (note that curve and acurve are the same). Each path also has an abbreviation which adds a forward arrow:

path { line }	@Line	@Arrow
path { doubleline }	@DoubleLine	@DoubleArrow
path { curve }	@Curve	@CurveArrow
path { acurve }	@ACurve	@ACurveArrow
path { ccurve }	@CCurve	@CCurveArrow
path { bezier }	@Bezier	@BezierArrow
path { hvline }	@HVLine	@HVArrow
path { vhline }	@VHLine	@VHArrow
path { hvcurve }	@HVCurve	@HVCurveArrow
path { vhcure }	@VHCurve	@VHCurveArrow
path { lvrline }	@LVRLLine	@LVRArrow
path { rvlline }	@RVLLLine	@RVLArrow
path { lvrcurve }	@LVRCurve	@LVRCurveArrow
path { rvlcurve }	@RVLCurve	@RVLCurveArrow
path { dhuline }	@DHULine	@DHUArrow
path { uhdline }	@UHDLine	@UHDArrow
path { dhucurve }	@DHUCurve	@DHUCurveArrow
path { uhdcure }	@RVLCurve	@RVLCurveArrow
path { hvhline }	@HVHLine	@HVHArrow

path { hvhline }	@VHVLine	@VHVArrow
path { hvhcurve }	@HVHCurve	@HVHCurveArrow
path { hvcurve }	@VHVCurve	@VHVCurveArrow
path { dwrapline }	@DWrapLine	@DWrapArrow
path { uwrapline }	@UWrapLine	@UWrapArrow
path { dwrapcurve }	@DWrapCurve	@DWrapCurveArrow
path { uwrapcurve }	@UWrapCurve	@UWrapCurveArrow

Here is the complete list of options to the @Link symbol. The options related to xlabel, ylabel, and zlabel have been omitted where they are the same as the linklabel options.

@Link			
path	{ line }		line, doubleline, curve, acurve, ccurve, bezier, vline, hvline, hvcurve, hvcurve, lvline, rvline, lvrcurve, rvlcurve, dhuline, uhline, dhucurve, uhdcurve, hvhline, hvhline, hvhcurve, hvhcurve, dwrapline, uwrapline, dwrapcurve, uwrapcurve, or any path
from	{ 0,0 }		any <i>point</i> or node label
to	{ 1,1 }		any <i>point</i> or node label
bias	{ 2.0f }		any <i>length</i>
fbias	{ 2.0f }		any <i>length</i>
tbias	{ 2.0f }		any <i>length</i>
hfrac	{ 0.5 }		any fractional <i>number</i>
hbias	{ 0.0f }		any <i>length</i>
radius	{ 1.0f }		any <i>length</i>
xindent	{ 0.8f }		any <i>length</i>
zindent	{ 0.8f }		any <i>length</i>
frompt	{ 0 0 }		any <i>point</i>
topt	{ 0 0 }		any <i>point</i>
pathstyle	{ solid }		solid, dashed, cdashed, dotted, dotdashed, dotcdashed, dotdotdashed, dotdotcdashed, dotdotdotdashed, dotdotdotcdashed, noline, or any sequence of one or more of these values
pathdashlength	{ 0.2f }		any <i>length</i>
pathwidth	{ thin }		thin, medium, thick, or any <i>length</i>
pathgap	{ thin }		thin, medium, thick, or any <i>length</i>
arrow	{ no }		no, yes, forward, back, or both
arrowstyle	{ solid }		solid, solidwithbar, halfopen, open, curvedsolid, curvedhalfopen, curvedopen, circle, box, or many
arrowwidth	{ 0.3f }		any <i>length</i>
arrowlength	{ 0.5f }		any <i>length</i>

backarrowstyle	{ solid }	solid, solidwithbar, halfopen, open, curvedsolid, curvedhalfopen, curvedopen, circle, box, or many
backarrowwidth	{ 0.3f }	any <i>length</i>
backarrowlength	{ 0.5f }	any <i>length</i>
linklabel	{ }	any object
linklabelmargin	{ 0.2f }	any length from Section 1.2
linklabelfont	{ -2p }	any value suitable for the @Font symbol
linklabelbreak	{ ragged nohyphen }	any value suitable for the @Break symbol
linklabelformat	{ @Body }	any object, usually containing @Body
linklabelpos	{ }	any <i>point</i>
linklabelangle	{ horizontal }	horizontal, aligned, or perpendicular; parallel, antiparallel, or any <i>angle</i>
linklabelprox	{ above }	above, below, left, right, inside, or outside; CTR, N, S, E, W, NE, NW, SW, SE, NNW, NNE, SSW, or SSE
linklabelctr	{ no }	yes or no
linklabeladjust	{ 0 0 }	any <i>point</i>
xlabelpos	{ LFROM }	any <i>point</i>
ylabelpos	{ LMID }	any <i>point</i>
ylabelctr	{ yes }	yes or no
zlabelpos	{ LTO }	any <i>point</i>
fromlabel	{ }	any object
fromlabelmargin	{ 0f }	any length from Section 1.2
fromlabelfont	{ -2p }	Any value suitable for the @Font symbol
fromlabelbreak	{ ragged nohyphen }	Any value suitable for the @Break symbol
fromlabelformat	{ @Body }	any object, usually containing @Body
fromlabelpos	{ FROM }	any <i>point</i>
fromlabelangle	{ antiparallel }	horizontal, aligned, or perpendicular; parallel, antiparallel, or any <i>angle</i>
fromlabelprox	{ W }	above, below, left, right, inside, or outside; CTR, N, S, E, W, NE, NW, SW, SE, NNW, NNE, SSW, or SSE
fromlabelctr	{ no }	yes or no
fromlabeladjust	{ 0 0 }	any <i>point</i>
tolabel	{ }	any object
tolabelmargin	{ 0f }	any length from Section 1.2
tolabelfont	{ -2p }	Any value suitable for the @Font symbol
tolabelbreak	{ ragged nohyphen }	Any value suitable for the @Break symbol
tolabelformat	{ @Body }	any object, usually containing @Body
tolabelpos	{ TO }	any <i>point</i>
tolabelangle	{ parallel }	horizontal, aligned, or perpendicular; parallel, antiparallel, or any <i>angle</i>
tolabelprox	{ W }	above, below, left, right, inside, or outside; CTR, N, S, E, W, NE, NW, SW, SE, NNW, NNE, SSW, or SSE

```

tolabelctr      { no          }      yes or no
tolabeladjust   { 0 0        }      any point
    
```

Here is the complete list of options to the @Tree symbol:

@Tree

```

treeindent { ctr }      left, ctr, right, or any length from Section 1.2
    
```

The @HTree option has a similar treeindent option, which may be top, ctr, foot, or any length from Section 1.2.

Here are all the syntax diagrams symbols, used within @SyntaxDiag usually but also available within @Diag. To begin with we have the six starter symbols:

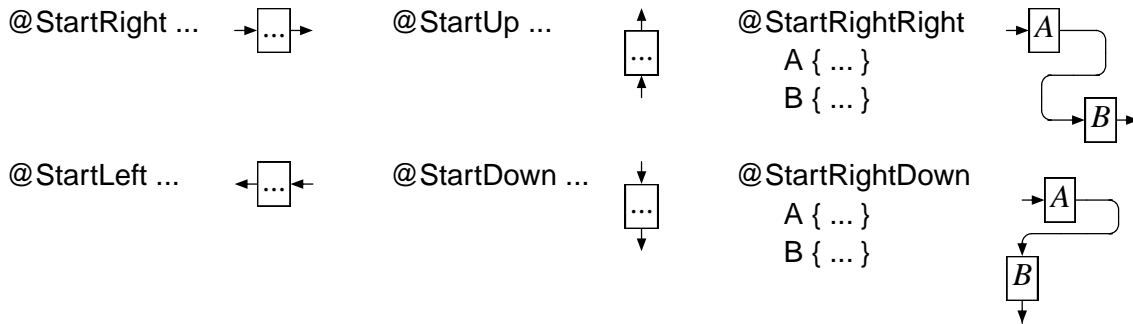

And here are all the syntax diagram types, shown in all four directions (right, up, left, and down).

@Sequence and @Select may have up to twelve options, A to L.

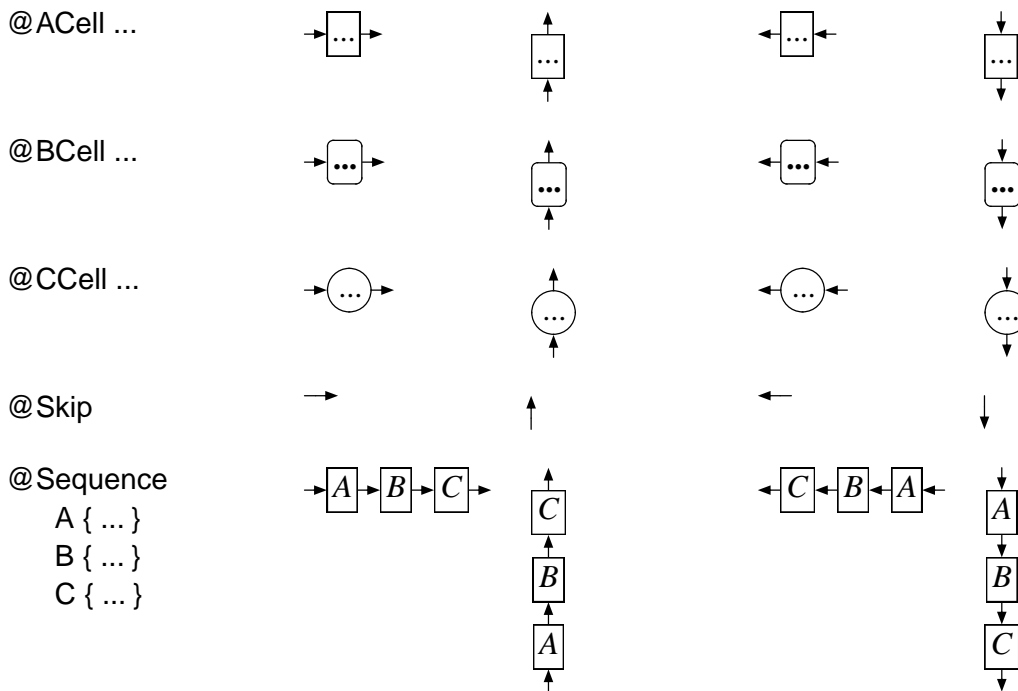

@Select

A { ... }
B { ... }
C { ... }

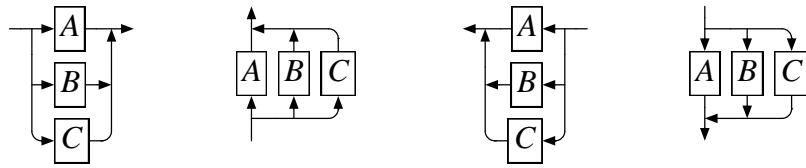

@Optional ...



@OptionalDiverted ...

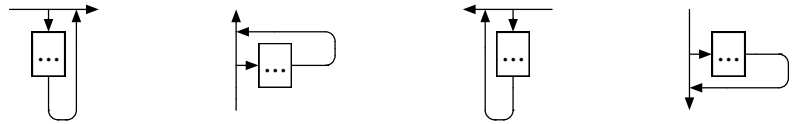

@Diverted ...

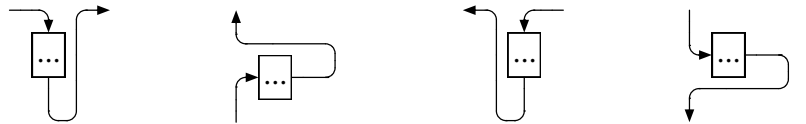

@OneOrBoth

A { ... }
B { ... }

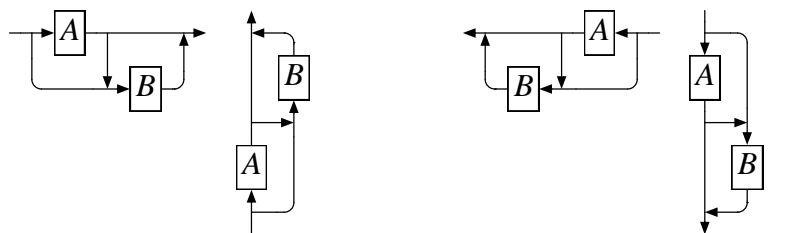

@Loop

A { ... }
B { ... }



@Repeat ...

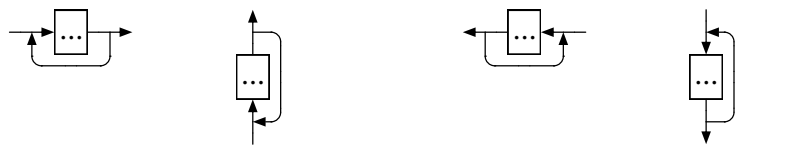

@LoopOpposite

A { ... }
B { ... }

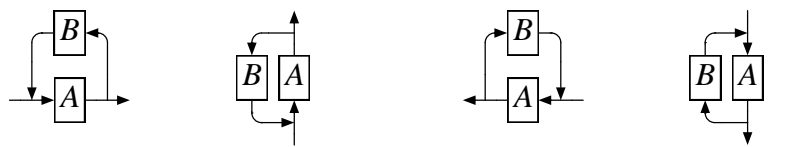

@RepeatOpposite ...

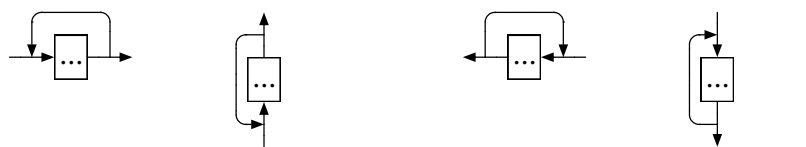

@RepeatDiverted ...

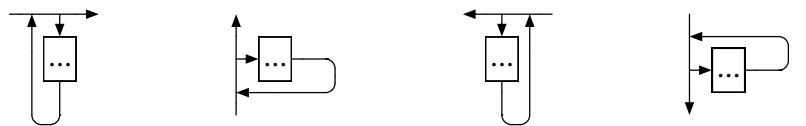

The @Diag symbol and to the @DiagSetup setup file symbol have all of the options of @Node, @Link, @Tree, and @HTree. They also have the following options:

@Diag

maxlabels	{ 200 }	any whole number
save	{ no }	no or yes
treehsep	{ 0.5f }	any length from Section 1.2
syntaxgap	{ 0.35f }	any length from Section 1.2
syntaxbias	{ 1.0f }	any length from Section 1.2
syntaxradius	{ 0.3f }	any length from Section 1.2

The following lists define all the ways to specify numbers, lengths, angles, points, and booleans. Brief explanations appear to the right, with the symbols' precedences in parentheses.

number

-27.56	or any literal number
<i>sqrt number</i>	square root (99)
<i>abs number</i>	absolute value (99)
<i>ceiling number</i>	least integer greater than or equal to (99)
<i>floor number</i>	greatest integer less than or equal to (99)
<i>truncate number</i>	delete fractional part (99)
<i>round number</i>	round to nearest integer (99)
<i>sin angle</i>	sine of angle measured in degrees (99)
<i>cos angle</i>	cosine of angle measured in degrees (99)
<i>number atan number</i>	arc tangent of first over second (98)
<i>number exp number</i>	first number raised to second number (98)
<i>number log number</i>	logarithm of second number to base first (98)
<i>number rand number</i>	random real number in this range inclusive (98)
<i>number max number</i>	the larger of two numbers (98)
<i>number min number</i>	the smaller of two numbers (98)
<i>number * number</i>	the product of two numbers (97)
<i>number / number</i>	real-valued division (96, left associative)
<i>length / length</i>	the ratio of two lengths (96, left associative)
<i>angle / angle</i>	the ratio of two angles (96, left associative)
<i>number idiv number</i>	integer division of two numbers (96, left associative)
<i>number mod number</i>	integer remainder when first divided by second (96)
<i>number + number</i>	sum of two numbers (96, left associative)
<i>+ number</i>	identity operation (96)
<i>number - number</i>	difference of two numbers (96, left associative)
<i>- number</i>	negation (96)
<i>sides</i>	(outline only) value of the node's sides option

length

0	zero
---	------

<i>xsize</i>	(outline only) distance to right boundary
<i>ysize</i>	(outline only) distance to top boundary
<i>xmark</i>	(outline only) distance to column mark
<i>ymark</i>	(outline only) distance to row mark
<i>margin</i>	(outline only) value of the node's margin option
<i>shadow</i>	(outline only) value of the node's shadow option
<i>number i</i>	<i>number</i> inches (100)
<i>number c</i>	<i>number</i> centimetres (100)
<i>number p</i>	<i>number</i> points (100)
<i>number m</i>	<i>number</i> ems (100)
<i>number s</i>	1s is the current width of a space (100)
<i>number v</i>	1v is the current inter-line space (100)
<i>number f</i>	1f is the size of the current font (100)
<i>xcoord point</i>	the <i>x</i> coordinate of the point (99)
<i>ycoord point</i>	the <i>y</i> coordinate of the point (99)
<i>abs length</i>	absolute value (99)
<i>length rand length</i>	random real length in this range inclusive (98)
<i>length max length</i>	the larger of two lengths (98)
<i>length min length</i>	the smaller of two lengths (98)
<i>point distance point</i>	(non-negative) distance between two points (98)
<i>length * number</i>	length multiplied by number (97)
<i>number * length</i>	length multiplied by number (97)
<i>length / number</i>	length divided by number (96, left associative)
<i>length + length</i>	sum of two lengths (96, left associative)
<i>+ length</i>	identity operation (96)
<i>length – length</i>	difference of two lengths (96, left associative)
<i>– length</i>	negation (96)
<i>angle</i>	
<i>number d</i>	<i>number</i> degrees (100)
<i>number</i>	<i>number</i> degrees (<i>d</i> is optional) (100)
<i>parallel</i>	(<i>labelangle</i> options only) angle parallel to curve at label point
<i>antiparallel</i>	(<i>labelangle</i> options only) angle antiparallel to curve at label point
<i>perpendicular</i>	(<i>labelangle</i> options only) angle perpendicular to curve at label point
<i>antiperpendicular</i>	(<i>labelangle</i> options only) angle antiperpendicular to curve at label point
<i>label??ANGLE</i>	angle parallel to curve at <i>label</i> if known, else 0d (99)
<i>anglefix angle</i>	<i>angle</i> normalized to between 0d inclusive and 360d exclusive (99)
<i>abs angle</i>	absolute value (99)

<i>length atan length</i>	arc tangent of first over second (98)
<i>point angleto point</i>	angle from first point to second (98)
<i>angle rand angle</i>	random angle in this range inclusive (98)
<i>angle max angle</i>	the larger of two angles (98)
<i>angle min angle</i>	the smaller of two angles (98)
<i>angle * number</i>	angle multiplied by number (97)
<i>number * angle</i>	angle multiplied by number (97)
<i>angle / number</i>	division of angle by number (96, left associative)
<i>angle + angle</i>	sum of two angles (96, left associative)
<i>+ angle</i>	identity operation (96)
<i>angle – angle</i>	difference of two angles (96, left associative)
<i>– angle</i>	negation (96)
<i>angle</i>	(outline only) value of the node's angle option
<i>point</i>	
<i>label</i>	a previously defined label
<i>any?label</i>	<i>any@label</i> if sensible, else <i>any</i> (99)
<i>prev</i>	the previous point in a shape
<i>length atangle angle</i>	point at distance and angle from origin (89)
<i>point/tag boundaryatangle angle</i>	<i>point</i> , or point on boundary of <i>tag</i> at <i>angle</i> (89)
<i>point ** number</i>	multiplication of point by number (88)
<i>point ++ point</i>	vector sum of two points (87)
<i>point — point</i>	vector difference of two points (87)
<i>number, number</i>	<i>x</i> and <i>y</i> coordinates with respect to base (70)
<i>length length</i>	<i>x</i> and <i>y</i> distance from origin (5)
<i>from</i>	(path only) the value of the link's from option
<i>to</i>	(path only) the value of the link's to option
<i>boolean</i>	
<i>number = number</i>	=; also between lengths (79)
<i>number != number</i>	≠; also between lengths (79)
<i>number == number</i>	= between angles (79)
<i>number != number</i>	≠ between angles (79)
<i>number <= number</i>	≤; also between lengths (79)
<i>number < number</i>	<; also between lengths (79)
<i>number >= number</i>	≥; also between lengths (79)
<i>number > number</i>	>; also between lengths (79)
<i>not boolean</i>	Logical not (78)
<i>boolean and boolean</i>	Logical and (77)
<i>boolean or boolean</i>	Logical or (76)
<i>boolean xor boolean</i>	Logical exclusive or (76)

A length is represented in PostScript by a single number on the operand stack; so is an angle. Therefore all number operations can be applied to lengths and angles as well, but the results will not always be useful. For example, rounding a length to the nearest integer is not a useful thing to do because the result depends on the basic unit (what does 1 equal as a length?) which is implementation-dependent and genuinely subject to change. Rounding the *ratio* of two lengths does make sense. The above is an attempt to list only the useful operations; but if you really need the logarithm of an angle, you can have it.

Angles are a little more amenable to this kind of thing because they are always measured in degrees. However, angles suffer from the problem that 0d is really the same angle as 360d. For this reason, separate equality and inequality operators for angles are provided which ignore multiples of 360d, and less than and similar relations are not defined for angles, because they inherently are not well defined. See also the `anglefix` symbol above.

A point is represented by two lengths (which are numbers) on the stack. Those familiar with PostScript and willing to sacrifice portability and increase their risk of error can therefore write, for example, `point exch` to obtain the reflection of a point about the main diagonal, and so on.

The following may have a result of any type, depending on their options. The options and result may be a sequence of things as required in shapes, including [] and so forth.

```

if
  cond { boolean }
  then { anything }
  else { anything }

angle quadcase
  0 { anything }
  0-90 { anything }
  90 { anything }
  90-180 { anything }
  180 { anything }
  180-270 { anything }
  270 { anything }
  270-360 { anything }

number signcase
  neg { anything }
  zero { anything }
  pos { anything }

xloop from { number } to { number } by { number } do {
  anything
}

yloop from { number } to { number } by { number } do {
  anything
}

```

```
xloop from { number } to { number } by { number } do {  
  anything  
}
```

The if symbol returns then or else depending on the value of *cond*, and signcase returns neg, zero, or pos depending on whether *number* (which may also be an angle or a length) is negative, zero, or positive. The quadcase symbol decides whether the given angle points in one of the four horizontal or vertical directions, or into the quadrants between them, and returns the appropriate option. Don't be misled by the unorthodox option names; it is not possible to give your own ranges, only these ones.

The loops return a sequence of repetitions of *anything*; any occurrences of *x* in *xloop* will be replaced by the current value of the loop counter, and similarly for the other loops.

Symbols not covered in this summary are the retagging symbol `::` (Section 9.4); the symbols available within the `@Tree` symbol (Section 9.6); and `:<`, `:=`, `@ShowPoints`, `@ShowTags`, and `@ShowDirections` from Section 9.10.

Chapter 10. Graphs

This chapter describes how to draw graphs, using the `@Graph` symbol. For example,

```
@Graph
  abovecaption { New South Wales road deaths, 1960--1990
(fatalities per 100 million vehicle km) }
{
  @Data points { plus } pairs { dashed }
  { 1963 5.6 1971 4.3 1976 3.7 1979 3.4 1982 2.9 1985 2.3 1988 2.0 }
}
```

produces the graph

New South Wales road deaths, 1960–1990
(fatalities per 100 million vehicle km)

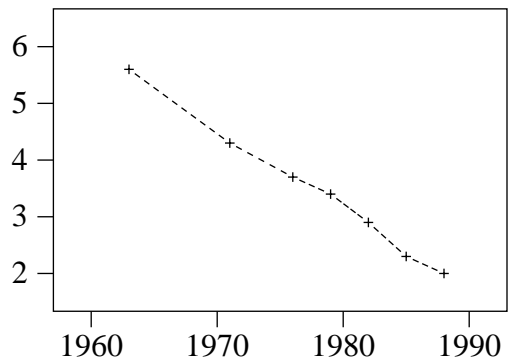

The features of `@Graph` include captions, automatic and manual ticks and labels, logarithmic axes, histograms, and plotting of mathematical functions.

10.1. Introduction

The Lout definitions for graph formatting are kept in a file called `graph`, which you must include at the start of your document if you want graphs, like this:

```
@SysInclude { graph }
@SysInclude { doc }
@Doc @Text @Begin
...
@end @Text
```

Setup files for specialized packages, such as `graph`, should be included before the main setup file. Once this is done, the `@Graph` symbol used below will then be available for use anywhere within

your document.

@Graph distinguishes between the overall graph, produced by the @Graph symbol itself, and the data sets to be placed within it, each of which is enclosed by a @Data symbol:

```
@CentredDisplay @Graph
{
  @Data points { plus }
  { 1 1.10 2 1.21 3 1.33 4 1.46 5 1.61 6 1.77 7 1.95 8 2.14 }

  @Data points { circle }
  { 1 1.20 2 1.44 3 1.73 4 2.07 5 2.45 6 2.99 7 3.58 8 4.30 }
}
```

Although it is good practice to lay the input data out neatly, layout has no effect on the result. It is not necessary to have one data point per line, for example. The result of this example is

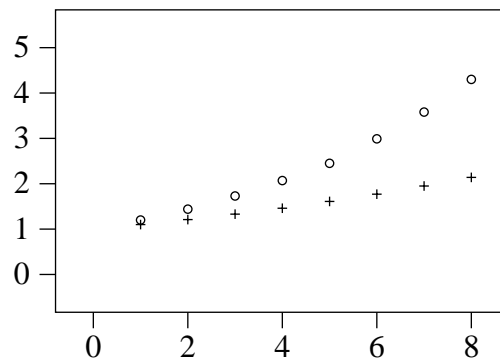

We have used the @CentredDisplay symbol from Section 2.1 to produce a centred display, but the @Graph symbol produces an object which may appear anywhere at all – in a figure, for example, or as an entry in a table.

10.2. Changing the overall appearance of the graph

The overall appearance of the graph is controlled by options to the @Graph symbol. As usual, these options follow the @Graph symbol, with their values enclosed in braces; they may appear in any order, and if omitted are assigned some sensible default value.

There is a style option for controlling the overall style of the graph, whose value may be either frame, grid, none, or axes. The default value is frame, and it produces a frame around the graph with ticks and labels along its left and bottom edges, as in previous examples. Value grid is similar except that the ticks are converted into grid lines crossing the entire frame. The none style prints nothing (no frame, no ticks, no labels), which is useful for producing graphs that don't look like graphs, as it were.

If axes is chosen, two other options called xorigin and yorigin become compulsory:

```

-2p @Font @Graph
  style { axes }
  xorigin { 0 }
  yorigin { 0 }
  width { 12c }
  height { 7c }
  leftcaption { 90d @Rotate { counts (%) } }
  leftgap { 1.0c }
  belowcaption { time (min) }
  belowgap { 0c }
{
  @Data
    points { filledsquare }
    pairs { solid }
  { 0 0.0 1 4.8 2 7.0 3 15.2 4 19.8 5 20.0 6 21.0 7 25.0
    10 29.5 15 31.2 20 35.0 30 40.0 60 50.8
  }

  @Data
    points { square }
    pairs { solid }
  {
    0 0.0 1 3.7 1.5 43.1 2 99.1 3 85.6 4 69.1 5 47.0 6 44.1 7 40.8
    10 35.0 15 29.4 20 25.0 30 21.1 60 15.5
  }
}

```

We have requested a smaller font size for this graph as a whole by preceding it with `-2p @Font`, meaning two points smaller, and we have used some other options which will be explained shortly. The resulting graph has an x axis and a y axis instead of a frame, like this:

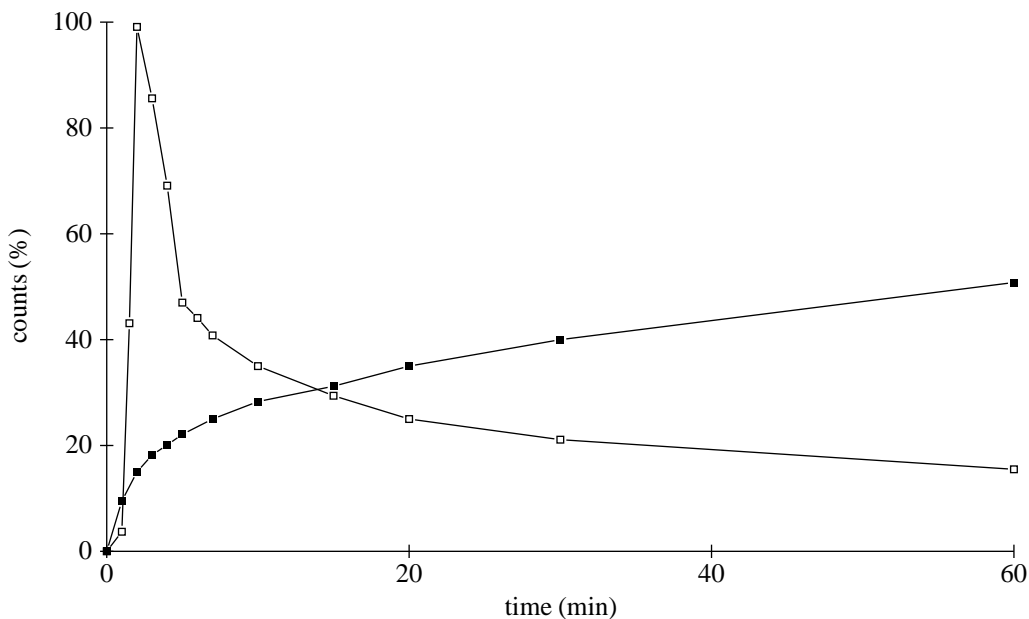

The point where the axes cross is (xorigin, yorigin).

Although @Graph does not provide explicit support for multiple axes, you can simulate them by overstriking two separate graphs of equal size. There is an @OverStrike symbol which overstrikes two objects, so

```
@Graph { ... } @OverStrike @Graph { ... }
```

will do the job. Typically one of the graphs would have y ticks, and the other would have x ticks (adjacent to the right-hand side of the frame).

There are xlog and ylog options which produce logarithmic x and y axes:

```
@Graph
  xlog { 10 }
  ylog { 10 }
{
  ...
}
```

The value is the base of the logarithm, usually 10 or 2, or none (the default) meaning not logarithmic. Logarithms to different bases differ only by a constant factor, so the main effect of different bases is on the choice of ticks and labels. An xlog option will be ignored if there are any negative or zero x data points, x ticks, or xorigin or xmin options; and similarly for ylog.

There are width and height options for setting the size of the total area enclosed:

```
@Graph
  width { 6.0c }
  height { 4.0c }
{
  ...
}
```

This shows the default width and height, six centimetres and four centimetres. These lengths and others discussed below can be specified using a variety of units of measurement (see Section 10.10 for the details).

Within the frame or axes, a small margin is kept free of data points. The size of this margin is controlled by xextra and yextra options:

```
@Graph
  xextra { 0.5c }
  yextra { 0.5c }
{
  ...
}
```

Setting xextra to 0.5c (the default value if the style option is frame) means that the smallest x value will be placed 0.5 centimetres to the right of the left boundary, and the largest will be placed 0.5 centimetres to the left of the right boundary. It is quite safe to set xextra to 0c if desired, and

indeed this is the default value when style is axes or none. The yextra option works in exactly the same way for y values.

The xdecreasing option plots the x values in decreasing order instead of increasing:

```
@Graph
  xdecreasing { yes }
  abovecaption { New South Wales road deaths, 1960--1990
(fatalities per 100 million vehicle km) }
{
  @Data
  points { plus }
  pairs { dashed }
  {
    1963 5.6 1971 4.3 1976 3.7 1979 3.4 1982 2.9 1985 2.3 1988 2.0
  }
}
```

produces

New South Wales road deaths, 1960–1990
(fatalities per 100 million vehicle km)

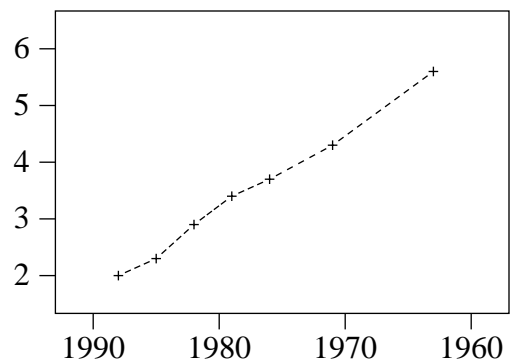

The value of xdecreasing should be either no (the default value) or yes. A similar ydecreasing option does the same thing to the y axis.

10.3. Captions

There are options for placing captions above, below, left, and right of the frame:

```
@Graph
  abovecaption { This appears above }
  belowcaption { This appears below }
  leftcaption { At left }
  rightcaption { At right }
{
}
```

produces

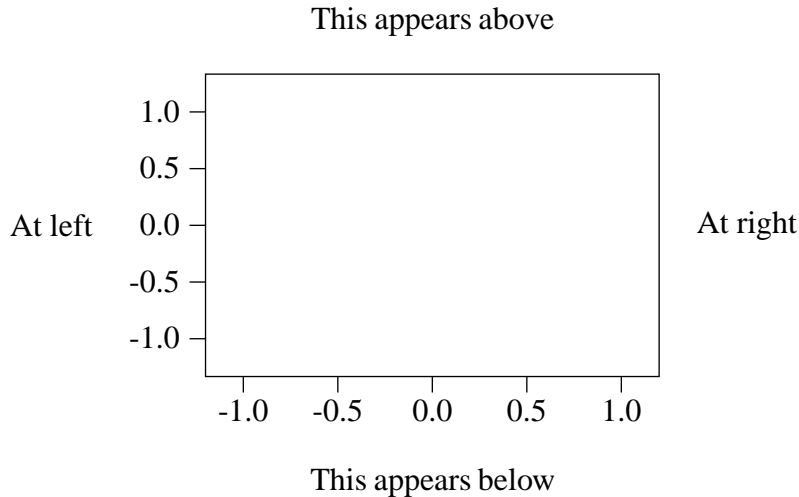

The captions may be arbitrary Lout objects, so may include equations, `@Rotate`, and so on. Each caption except `rightcaption` is printed in the clines `@Break` style, which means that multiple lines in one caption will be centred beneath each other. The `rightcaption` option uses the lines `@Break` style, in which the lines are left justified beneath each other. Incidentally, this example shows what happens if there is no data.

There are options for controlling the amount of space between each caption (when non-empty) and the frame. Here they are with their default values:

```
@Graph
  abovegap { 0.5c }
  belowgap { 0.5c }
  leftgap  { 1.5c }
  rightgap { 0.5c }
{
  ...
}
```

This is particularly important in the case of `leftgap` (and `rightgap` if `rticks` is used), because Lout has no idea how wide the ticks and labels attached to the y axis are; `1.5c` is just a wild guess and often needs adjustment. On the other hand, Lout does know how high the ticks and labels on the x axis are; it allows 1.7 times the current font size for them, and `belowgap` is additional to this.

When a graph is to be presented as a centred display, it is generally best if the centring is done with respect to the frame alone, not the captions, ticks, and labels. The `hidecaptions` option does this by making the left and right captions and gaps seem to Lout to have zero width:

```
@Graph
  hidecaptions { yes }
{
  ...
}
```

Actually `yes` has been made the default value, since the vast majority of graphs are centred displays. In the rare cases where this feature is not wanted (for example, if a graph appears as an entry in a table), use `hidecaptions { no }`. The `y` and `r` ticks and labels seem to Lout to have zero width already, so do not need to be hidden.

10.4. Ticks and labels

Ticks are the short lines that mark off intervals along the axes, and *labels* are the numbers appearing near the ticks (not to be confused with captions). `@Graph` produces ticks and labels automatically with some care, so it is probably best not to worry about them unless the result is not pleasing, in which case there are options for controlling them.

One simple way to control the production of `x` ticks is with the `xmin`, `xmax`, and `xticksep` options to `@Graph`. For example,

```
@Graph
  xmin { 0 }
  xmax { 5 }
  xticksep { 0.5 }
```

specifies that `x` values in the range 0 to 5 are to be expected, and that a tick and label is to appear every 0.5 units along the `x` axis. One or both of `xmin` and `xmax` may be omitted, in which case suitable values will be inferred from the data as usual.

Alternatively, complete control over the appearance of `x` ticks and labels is provided by the `xticks` option. For example,

```
@Graph
  xticks { 0@ 5 10@ 15 20@ }
```

specifies that `x` ticks are to be drawn at 0, 5, 10, 15, and 20. An `@` following a number indicates that a label is to be printed as well, so the above example will produce labels at 0, 10, and 20. For even finer control, `@` may be replaced by a label enclosed in parentheses:

```
@Graph
  xticks { 1 (Democrat) 2 (Republican) 3 (Other) }
```

As this example shows, a label does not have to be a number; it can be any string of characters, including spaces and balanced parentheses; but it may not be an arbitrary Lout object.

The character `^` in a label indicates that the remainder is to be treated as an exponent:

```
@Graph
  xlog { 10 }
  xticks { 1 (1) 10 (10) 100 (10^2) 1000 (10^3) 10000 (10^4) 100000 (10^5) }
  {
    @Data points { plus }
    { 1 2.1 10 3.4 100 4.9 1000 6.1 10000 7.2 100000 7.6 }
  }
```

In fact, the labels inserted automatically when `xticks` is omitted have exponents when the axis is logarithmic, so `xticks` is hardly necessary in this example. Anyway the result is

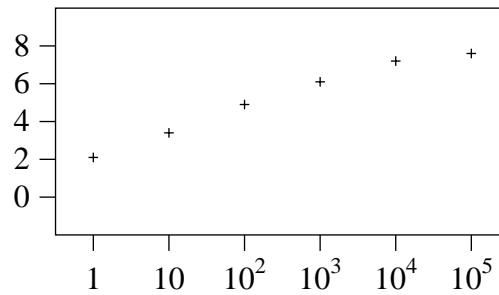

Setting `xticks` to empty produces no x ticks (this is not the same as omitting `xticks`).

Similar options control ticks and labels on the y axis: `ymin`, `ymax`, `yticksep`, and `yticks`. There are also `xticklength` and `yticklength` options which set the length of ticks:

```
@Graph
  xticklength { 0.5f }
  yticklength { 0.5f }
```

shows the default values, half the current font size in both cases.

There is also an `rticks` option which is similar to `yticks` except that the ticks it controls appear on the right-hand side of the frame (this option is relevant only when the style option is `frame`). Unlike `xticks` and `yticks`, `rticks` has empty default value, which is why you don't usually see r ticks. They are most useful when overstriking two graphs using `@OverStrike` as explained earlier; one graph will have y ticks in the usual way, the other will have r ticks and empty y ticks:

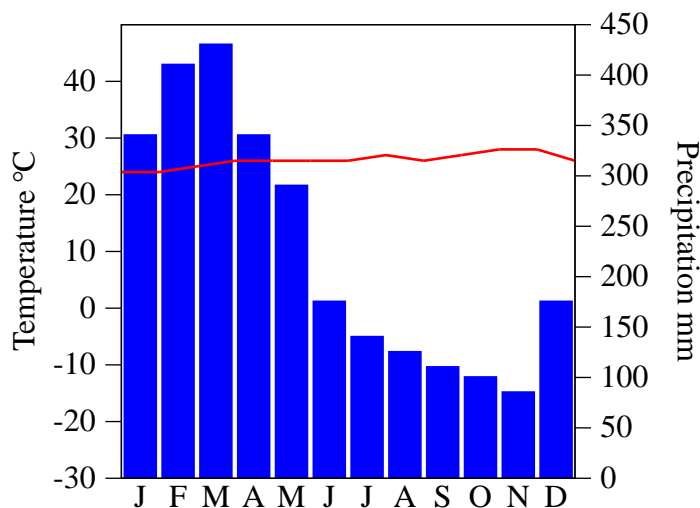

Here the first graph has

```
rticks { 0@ 50@ 100@ 150@ 200@ 250@ 300@ 350@ 400@ 450@ }
yticks { }
```

for its ticks. This graph uses other features that we have not come to yet, but anyway its source is:

```

@Graph
  style { frame }
  width { 6c }
  height { 6c }
  xextra { 0c }
  yextra { 0c }
  rightcaption { -90d @Rotate { Precipitation mm } }
  rightgap { 3.0f }
  hidecaptions { no }
  xmin { 0 }
  xmax { 12 }
  ymin { 0 }
  ymax { 450 }
  xticks { }
  xticklength { 0c }
  rticks { 0@ 50@ 100@ 150@ 200@ 250@ 300@ 350@ 400@ 450@ }
  yticks { }
{
  @Data pairs { filledyhisto } colour { blue } linewidth { 1p }
  {
    0 340 1 410 2 430 3 340 4 290 5 175 6 140
    7 125 8 110 9 100 10 85 11 175 12 0
  }
}

```

```
@OverStrike
```

```

@Graph
  style { frame }
  width { 6c }
  height { 6c }
  xextra { 0c }
  yextra { 0c }
  leftcaption { 90d @Rotate { Temperature {@Degree}C } }
  leftgap { 2.5f }
  hidecaptions { no }
  xmin { 0 }
  xmax { 12 }
  ymin { -30 }
  ymax { 50 }
  xticks {
    0.5 (J) 1.5 (F) 2.5 (M) 3.5 (A) 4.5 (M) 5.5 (J)
    6.5 (J) 7.5 (A) 8.5 (S) 9.5 (O) 10.5 (N) 11.5 (D)
  }
  xticklength { 0c }
  yticks { -30@ -20@ -10@ 0@ 10@ 20@ 30@ 40@ }
{
  @Data pairs { solid } colour { red } linewidth { 1p }
  {
    0.0 24 1.0 24 2.0 25 3.0 26 4.0 26 5.0 26 6.0
    26 7.0 27 8.0 26 9.0 27 10.0 28 11.0 28 12.0 26
  }
}

```

Lout has only a hazy idea of how much space is occupied by ticks and labels. Unless `xticks` is empty, Lout allows 1.7 times the current font size below the graph for x ticks and labels, which is usually about right; but it does not allow any space for y and r ticks and labels since it has no idea how wide the labels will be. The discussion of captions in Section 10.3 explains how to use the `leftgap` and `rightgap` options to work around this deficiency.

10.5. Changing the appearance of the data

The `@Data` symbol has options for controlling the appearance of its data. We have already seen the `points` option, which controls what is printed at each data point:

<code>cross</code>	×	<code>plus</code>	+
<code>square</code>	□	<code>filledsquare</code>	■
<code>diamond</code>	◇	<code>fillediamond</code>	◆
<code>circle</code>	○	<code>filledcircle</code>	●
<code>triangle</code>	△	<code>filledtriangle</code>	▲

Filled and open squares have exactly the same size, filled and open diamonds have exactly the same size, and so on. If the `points` option is omitted or empty, nothing is printed. The symbols are centred over the data point. There is a `symbolsize` option which controls the size (radius) of all these symbols, and a `symbollinewidth` option¹ which controls their line width:

```
@Data
  symbolsize { 0.15f }
  symbollinewidth { 0.5p }
```

shows their default values, 0.15 times the current font size and half a point. More precisely, these default values are taken from options to the `@Graph` symbol with the same names. By setting those options you can therefore control all data points in the graph at once. The `symbollinewidth` option does not affect the appearance of `filledsquare`, `fillediamond`, `filledcircle`, or `filledtriangle`.

The `@Data` symbol also has a `pairs` option which determines how each pair of points is connected. The choices are `none` (not connected, the default), `solid` (a solid line), `dashed` (a dashed line), `dotted` (a dotted line), or `dotdashed`, `dotdotdashed`, and `dotdotdotdashed` for mixing dots and dashes. For example,

¹The `symbollinewidth` option was introduced in Version 3.37, as part of a bug fix which also caused the printed size of some symbols to change slightly.

@Graph

```

abovecaption { Estimated population of Boston, New York, and Philadelphia }
{
  @Data points { plus } pairs { solid }
  { 1720 12000 1730 13000 1740 15601 1760 15631 1770 15877 }

  @Data points { plus } pairs { dashed }
  { 1720 7000 1730 8622 1740 10451 1750 14255 1760 18000 1770 22667 }

  @Data points { plus } pairs { dotdashed }
  { 1720 10000 1730 11500 1740 12654 1750 18202 1760 23750 1770 34583 }
}

```

produces

Estimated population of Boston, New York, and Philadelphia

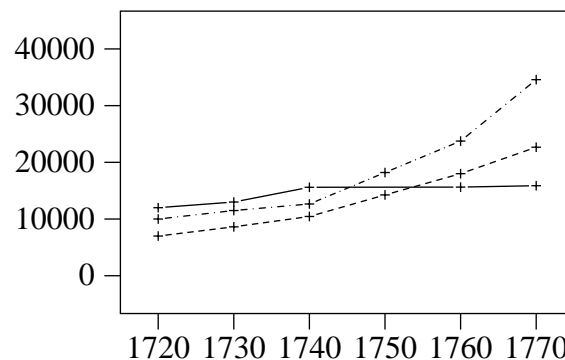

(R. C. Simmons, *The American Colonies*, W. W. Norton, New York, 1981.) We will see in Section 10.8 how to add an explanatory key to this graph. If the points have symbols, these connecting lines will stop 1.5 symbol sizes away from the data points, so as not to overstrike them. If the points have no symbols and pairs is dashed, the first and last dash in each segment will have half the length of the others.

A dashlength option controls the length of dashes and also the separation between dots, and a linewidth option controls the width (thickness) of the lines and dots:

```

@Data
  dashlength { 0.2f }
  linewidth { 0.5p }
{
  ...
}

```

This shows the default values, 0.2f for dashlength and 0.5p (half a point) for linewidth. Actually the default value for linewidth is whatever happens to be already in use, but Lout sets line widths to half a point initially. This option also controls the separation between bars in histograms.

The pairs option is also used for producing histograms, like this:

```

@Graph
  hidecaptions { yes }
  abovecaption { Computer Science 3 Results (1993) }
  leftcaption { Number of
students }
  belowcaption { Final mark (%) }
  yextra { 0c }
  ymax { 80 }
{
  @Data pairs { yhisto }
  { 0 1 10 3 20 2 30 4 40 15 50 60 60 58 70 28 80 15 90 7 100 0 }
}

```

which has result

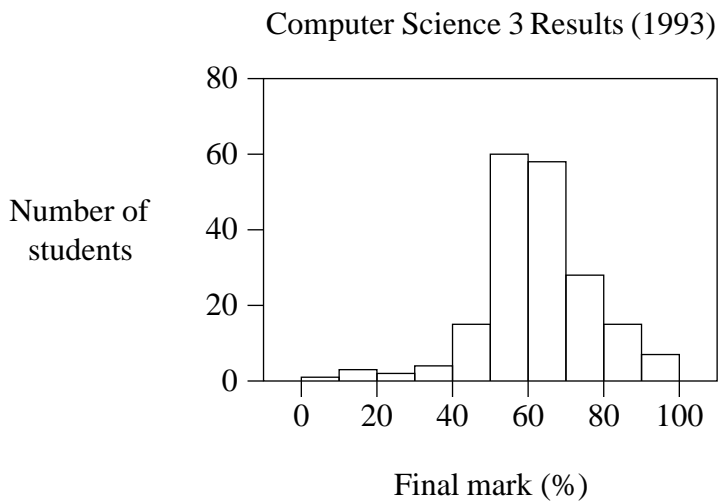

Note carefully that one y histogram rectangle occupies the space from one x value to the next, with height equal to the y value lying between these two x values. This means that the very last y value has no effect on the result (however, there must be a last y value anyway).

There is an alternative to yhisto called surfaceyhisto:

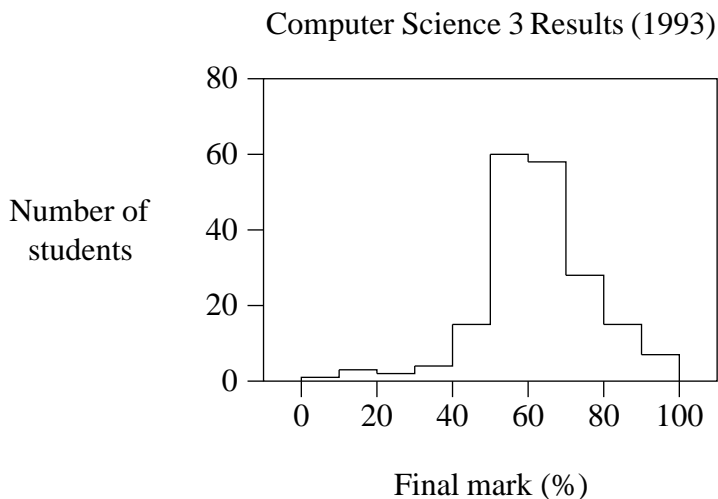

As you can see, `surfaceyhisto` draws just the surface of the histogram, not the descending lines.

There are `xhisto` and `surfacexhisto` values of pairs which produce a histogram whose bars are parallel to the x axis. There are also `filledyhisto` and `filledxhisto` values which produce filled rectangles rather than outlined ones:

```
@Graph
  abovecaption { Fertility rates in some developing countries }
  xextra { 0c }
  yextra { 0c }
  xmax { 8 }
  yticks {
    1.5 (Turkey) 2.5 (Thailand)
    3.5 (Indonesia) 4.5 (Costa Rica)
    5.5 (Colombia) 6.5 (Cameroon)
    7.5 (Botswana) 8.5 (Bangladesh)
  }
  yticklength { 0c }
{
  @Data
  pairs { filledxhisto }
  { 0 1 3.2 2 2.2 3 3.0 4 3.5 5 2.8 6 5.9 7 4.8 8 5.3 9 }
}
```

produces

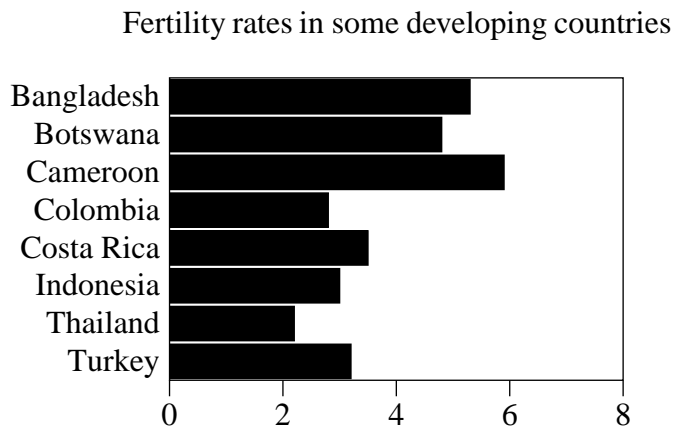

(Bryant Robey, Shea O. Rutstein, and Leo Morros: The fertility decline in developing countries, *Scientific American*, December 1993.) Once again each bar goes from one y value to the next, with its x value equal to the x value lying between the two y values; this time the very first x value has no effect on the result.

The colour of one set of data can be changed with a colour option:

```
@Data
  colour { blue }
```

For the complete list of acceptable colours, see Section 8.1. The colour option's name may also

be spelt color.

It is also possible to paint the area between the data points and the x axis (or frame if style is not axes), using

```
@Data
  paint { yes }
```

The paint colour is determined by the colour option just introduced; it will be black if no colour is specified. Paint (including white paint) hides paint, points, and lines drawn by previous data sets. However the points and lines of each data set are drawn after painting that set, so they cannot be hidden under their own paint; and axes and frames are drawn last so that they too are never hidden.

Wherever there is a paint option in Lout's standard packages, there is a neighbouring texture option. For historical reasons the paint option of @Graph is not quite the same as other paint options, but the texture option is available as usual:

```
@Graph
  yextra { 0c }
{
  @Data
    paint { yes }
    texture { chessboard angle { 45d } }
  { 0 0.00 1 1.00 2 1.50 3 1.83 4 2.08 5 2.28 6 2.45 }
}
```

produces¹

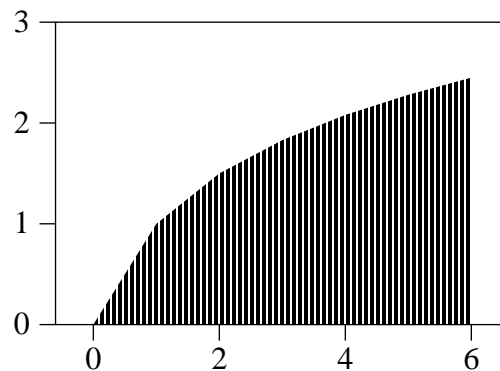

Any value acceptable to the texture option of @Box (Section 8.3) is acceptable here. The texture option will also give a texture to the filled areas of a filledxhisto or filledyhisto:

¹If you can't see any textures here, the fault is probably with your PostScript viewer. See Section 8.2.

```
@Graph
  yextra { 0c }
  {
    @Data
      pairs { filledyhisto }
      texture { striped angle { 45d } }
      { 0 0.00 1 1.00 2 1.50 3 1.83 4 2.08 5 2.28 6 2.45 7 0 }
  }
}
```

produces

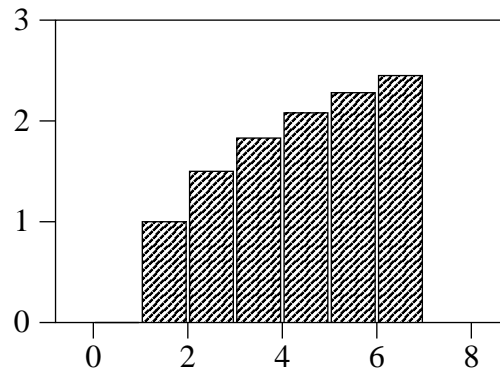

If you want the bars to vary in colour or texture, you have to give multiple @Data sets, one for each combination of colour and texture.

A dataformat option is provided for changing the interpretation of the data. Ordinarily, as we know, the numbers are taken to be pairs of x and y coordinates, like this:

```
@Data
{
  x y x y ... x y
}
```

However, by setting dataformat to yonly, the interpretation is changed to a sequence of y coordinates only:

```
@Data
  dataformat { yonly }
  {
    y y ... y
  }
```

and x values 1, 2, and so on are inserted automatically, as though the original input was

```
@Data
{
  1 y 2 y ...
}
```

Similarly, xonly inserts y values 1, 2, and so on. The default value, xandy, gives the usual inter-

pretation, and `swapxandy` exchanges adjacent pairs of numbers: the data is interpreted as (y,x) pairs rather than (x,y) pairs. The layout of data on lines has no effect on the interpretation.

10.6. Placing arbitrary objects on the graph

As we have just seen, the repertoire of symbols that `@Data` is able to place on the graph is quite limited. However, there is a way to place any number of arbitrary Lout objects anywhere on the graph, using the `objects` option to the `@Graph` symbol:

```
@Graph
  objects {
    @CTR at {2.5 6.0} @Math { y = x sup 2 }
    @CTR at {4.5 7.0} @Math { y = x sup 3 }
  }
```

where we have used the `@Math` symbol from Chapter 7 to place two equations onto the graph at the points 2.5 6.0 and 4.5 7.0 respectively. An example result appears in the next section.

In addition to `@CTR`, there are eight other symbols which may be used within the `objects` option in the same way: `@NW`, `@SW`, `@SE`, `@NE`, `@N`, `@W`, `@S`, and `@E`. These place the object just to the northwest of the point, to the southwest, and so on instead of centring it over the point. By ‘to the northwest’ we mean that the object’s bottom right corner coincides with the point, and similarly for the other symbols.

Each of these symbols has a `margin` option which enlarges the object by adding a margin:

```
@NW at {2.5 6.0} margin { 0.3f } @Eq { y = x sup 2 }
```

shows the default value, 0.3 times the current font size. As the margin is increased, the object moves further away from the point.

The major advantage of the `objects` option over the `@Data` symbol is that arbitrary Lout objects may be used. The `@Data` symbol however is able to place many copies of its symbols onto the graph, and also allow for them when connecting points together with lines. Also, the points within the `objects` option are not taken into account when deciding on the permissible range of x and y values, whereas the points within the `@Data` symbol are. Altogether it seems best to use the `@Data` symbol for the bulk of the data points, and to use the `objects` option for adding a small number of labels or other decorations.

The `objects` option may contain `@Graph` symbols, but in that case, owing to a deficiency in the implementation, those symbols must have their `save` options (Section 10.9) set to `yes`.

10.7. Mathematical functions, loops, and tests

`@Graph` offers quite a large selection of mathematical functions, available everywhere that x and y coordinates are required: within the `xticks` and `yticks` options, within the points within the `objects` option, and within the `right` parameter of the `@Data` symbol. For example,

```
@Data
pairs { solid }
{
  0 0 pi sin { pi/2 }
}
```

draws a solid line from $(0, 0)$ to $(\pi, \sin(\pi/2))$. Section 10.10 lists all the functions; they include the four arithmetical operators $+$, $-$, $*$, and $/$, as well as \sin , \cos , $\sqrt{\quad}$, and many others. Braces are used for grouping, never parentheses.

For plotting functions there are three looping symbols, `xloop`, `yloop`, and `zloop`. For example, the following plots the two functions $y = 2$ and $y = \sqrt{\pi x/4} + 1$ for x from 10 to 500:

```
-2p @Font @Graph
style { axes }
xorigin { 0 }
yorigin { 0 }
width { 8c }
xticks { 10@ 50@ 100@ 200@ 500@ }
objects { @NE at { 300 2 } @I { Exponential }
          @SE at { 300 sqrt { pi*300/4 } + 1 } @I { Uniform } }
belowcaption { @I n }
belowgap { 0c }
leftcaption { Right shell nodes }
{
  @Data points { filledcircle }
  { 10 1.97 50 2.01 100 2.00 200 2.0 500 2.00 }

  @Data points { filledcircle }
  { 10 3.53 50 7.45 100 9.32 200 13.41 500 21.63 }

  @Data pairs { dashed }
  { 10 2 500 2 }

  @Data pairs { dashed }
  {
    xloop from { 10 } to { 500 } by { 20 } do
    {
      x sqrt { pi*x / 4 } + 1
    }
  }
}
```

The `do` option of `xloop` is replicated repeatedly with each occurrence of x replaced by 10, 30, 50, ... up to 490. The result is¹

¹ Source: Jeffrey H. Kingston, Analysis of tree algorithms for the simulation event list. *Acta Informatica* 22, pp. 15–33 (1985).

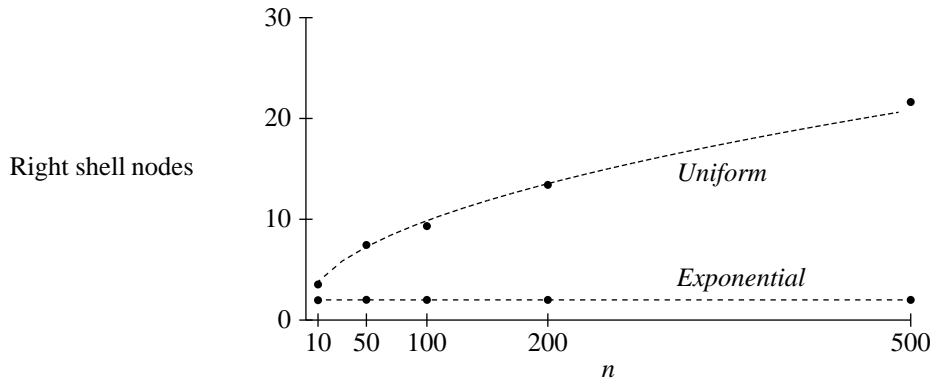

The points are connected by straight line segments as usual, but a smallish by option of about one-twentieth of the range creates the illusion of a smooth curve quite well.

There is also an `if` symbol which produces alternative results, depending on whether a condition evaluates to true or false:

```
xloop from { -5 } to { +5 } by { 0.2 } do
{
  if cond { abs { x } > 0.1 } then { x 1/x } else {}
}
```

This plots the function $y = 1/x$, skipping points near zero. Actually the `else` part could be omitted since its default value is empty.

Adventurous users might enjoy nesting a `yloop` or `zloop` within an `xloop`, or using loops to generate ticks, like this:

```
xticks {
  xloop from { 0 } to { 20 } do
  {
    x if cond { x mod 5 = 0 } then { @ }
  }
}
```

The `missing` by option defaults to 1, so this produces `x` ticks at 0, 1, 2, ..., 20, with labels at 0, 5, 10, 15, and 20. It is quite all right to mix `@` and even labels in with numbers, as long as the final result obeys the rules of Section 10.4.

You can define your own functions using Lout definitions, placed in your `mydefs` file as explained in Section 2.13. Here is an example of a function definition:

```
import @Graph @Data
def @Tan
  precedence 40
  right x
{
  sin x / cos x
}
```

This defines a function called `@Tan` which implements the trigonometric tangent function. It

may then be used in expressions just like any other function:

```
@Data {
  yloop from { 0 } to { 0.95 } by { 0.05 } do
  {
    y @Tan { y / pi }
  }
}
```

Following is a detailed explanation.

The first line, `import @Graph @Data`, is the import clause. Its function is to grant the definition access to the three previously defined functions (symbols) that it uses, namely `sin`, `cos`, and `/`. These are found within the `@Data` symbol within `@Graph`.

After the import clause comes the `def` keyword, meaning ‘define,’ and then the name of the symbol being defined, in this case `@Tan`. We have chosen `@Tan` rather than `tan` because symbols defined by the user in this way are visible throughout the document, and we do not want the literal word `tan` to be taken as a symbol.

Next comes the symbol’s precedence, in this case the same as `sin` and `cos` (see Section 9.12 for the precedence of each symbol). Next is a list of the formal parameters, in this case just one, called `x`, that is to be passed on the right.

Finally comes the body of the definition enclosed in braces. When `@Tan` is invoked, its value will be this body with each occurrence of the formal parameter `x` replaced by the object following the `@Tan` symbol. For example, the `do` option of the `yloop` above becomes

```
y sin { y / pi } / cos { y / pi }
```

as you would expect.

10.8. Adding a key to the graph

A *key* to a graph is an explanation of what each data set represents. To assist you in constructing a key, some extra symbols are provided in addition to `@Graph`:

@GraphCross	×	@GraphPlus	+
@GraphSquare	□	@GraphFilledSquare	■
@GraphDiamond	◇	@GraphFilledDiamond	◆
@GraphCircle	○	@GraphFilledCircle	●
@GraphTriangle	△	@GraphFilledTriangle	▲
@GraphNoLine			
@GraphSolid	—		
@GraphDashed	---		
@GraphDotted		
@GraphDotDashed	-.-.-		
@GraphDotDotDashed	-.-.-		
@GraphDotDotDotDashed	-.-.-.		

These extra symbols may be used anywhere in your document except within the right parameter of @Graph; they are commonly used within the caption options of @Graph:

```
@Graph
  rightcaption {
    @GraphPlus @GraphSolid @GraphPlus Boston
    @GraphPlus @GraphDashed @GraphPlus New York
    @GraphPlus @GraphDotDashed @GraphPlus Philadelphia
  }
```

(You can also use them within the objects option, which is the way to place your key within the graph itself.) Recall that unlike the other captions, rightcaption is set using the lines @Break style rather than clines @Break (Section 10.3). Adding this caption to the graph from Section 10.5, the complete result is

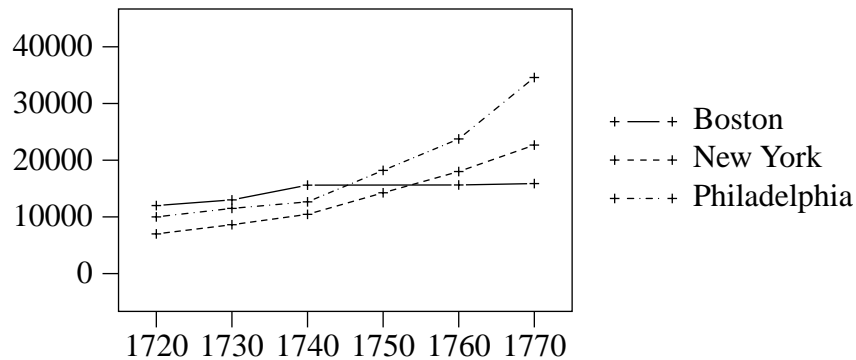

The first eight symbols have a `symbolsize` and `symbollinewidth` options with the usual meaning and the usual default values (0.15f and 0.5p). The last four symbols have `dashlength` and `linewidth` options with the usual default values, 0.2f and 0.5p, and a `length` option, which determines the length of the line drawn by each symbol; its default value is 1.0f.

10.9. Errors

Lout normally produces output that will print without mishap on any PostScript device. However, some of the options of `@Graph` and all of the data and labels are passed through Lout without checking. Any errors in this material will not be detected until the file is printed.

The most likely errors are *rangecheck errors*, for example if an attempt is made to divide by zero or take the square root of a negative number, and *undefined errors*, arising from symbols misspelt, use of `x` outside an `xloop`, etc. Less commonly, everything may be correct but the graph is too large in some way: too much data, expression too deeply nested, and so on.

When an error is detected, `@Graph` arranges for the offending page to be printed up to the point where the error occurred, with a message nearby describing the error. Printing of the document is then aborted. The problem is usually easy to locate since it lies in whatever should have been printed next.

If you see `VMerror` in an error message, it means that the printer has run out of memory. All the data is stored in the printer while the graph is being printed, and it remains there until the end of the current page, when it is discarded and all memory consumed by the graph is reclaimed. If you do run out of memory, one option is to try

```
@Graph
  save { yes }
...
```

This causes the memory used by the graph to be reclaimed as soon as the graph is printed, which might well solve your problem if you have several graphs on one page. However, if the graph is nested inside some other major Lout package, notably `@Diag`, this option could cause PostScript errors in that package.

10.10. Summary

The options to the `@Graph` symbol, their default values, and their possible values are:

@Graph		
style	{ frame }	frame, grid, axes, or none
width	{ 6.0c }	any <i>distance</i>
height	{ 4.0c }	any <i>distance</i>
xextra	{ 0.5c }	any <i>distance</i> (axes and none default is 0c)
yextra	{ 0.5c }	any <i>distance</i> (axes and none default is 0c)
xdecreasing	{ no }	yes or no
ydecreasing	{ no }	yes or no
leftcaption	{ }	any Lout object
rightcaption	{ }	any Lout object
abovecaption	{ }	any Lout object
belowcaption	{ }	any Lout object
leftgap	{ 1.5c }	any <i>distance</i>
rightgap	{ 0.5c }	any <i>distance</i>
abovegap	{ 0.5c }	any <i>distance</i>
belowgap	{ 0.5c }	any <i>distance</i>
hidecaptions	{ yes }	yes or no
xorigin	{ none }	none or any <i>number</i>
yorigin	{ none }	none or any <i>number</i>
xlog	{ none }	none or any <i>number</i> greater than 1
ylog	{ none }	none or any <i>number</i> greater than 1
xmin	{ none }	none or any <i>number</i>
xmax	{ none }	none or any <i>number</i>
ymin	{ none }	none or any <i>number</i>
ymax	{ none }	none or any <i>number</i>
xticksep	{ none }	none or any <i>number</i> greater than 0
yticksep	{ none }	none or any <i>number</i> greater than 0
rticksep	{ none }	none or any <i>number</i> greater than 0
xticks	{ auto }	<i>sequence</i> (of numbers and strings), or auto meaning automatic
yticks	{ auto }	<i>sequence</i> (of numbers and strings), or auto meaning automatic
rticks	{ }	<i>sequence</i> (of numbers and strings), or auto meaning automatic
xticklength	{ 0.5f }	any <i>distance</i>
yticklength	{ 0.5f }	any <i>distance</i>
rticklength	{ 0.5f }	any <i>distance</i>
objects	{ }	sequence of @CTR, @NW, @SW, @SE, @NE, @N, @W, @S, @E symbols
points	{ none }	none, plus, cross, square, filledsquare, diamond, filleddiamond, circle, filledcircle, triangle, filledtriangle
pairs	{ none }	none, solid, dashed, dotted, dotdashed, dotdotdashed, dotdot-dotdashed, yhisto, xhisto, filledyhisto, filledxhisto, surfaceyhisto, surfacexhisto
colour/color	{ none }	none or any colour from Section 8.1
paint	{ no }	no or yes
texture	{ solid }	any texture from Section 8.2
dataformat	{ xandy }	xandy, yonly, xonly, swapxandy
dashlength	{ 0.2f }	any <i>distance</i>
linewidth	{ 0.5p }	any <i>distance</i>
symbolsize	{ 0.15f }	any <i>distance</i>
symbollinewidth	{ 0.5p }	any <i>distance</i>

Number means an ordinary decimal number; *distance* means a number with a unit of measurement (Section 1.2), such as 5c or 0.5f. In general, numbers denote x or y values while distances denote lengths on the printed result.

The minimum plottable x value is the minimum of all the x data, xticks, xorigin, xmin, and xmax whenever these are not none. If xticks is none, this minimum may be reduced further to a ‘round’ number. The maximum plottable x value is the maximum of the same values, and it may be increased further if xticks is none. Similar remarks apply to y values.

The value of the objects option is a sequence of zero or more of the following:

@CTR	at { <i>expression expression</i> }	<i>object</i>
@NW	at { <i>expression expression</i> }	<i>object</i>
@SW	at { <i>expression expression</i> }	<i>object</i>
@SE	at { <i>expression expression</i> }	<i>object</i>
@NE	at { <i>expression expression</i> }	<i>object</i>
@N	at { <i>expression expression</i> }	<i>object</i>
@W	at { <i>expression expression</i> }	<i>object</i>
@S	at { <i>expression expression</i> }	<i>object</i>
@E	at { <i>expression expression</i> }	<i>object</i>

where *object* is an arbitrary Lout object. Each of these nine symbols also has a margin option whose value may be any non-negative distance, with default value 0.3f.

The options to the @Data symbol, their default values, and their possible values are:

@Data		
points	{ <i>inherited</i> }	none, plus, cross, square, filledsquare, diamond, filleddiamond, circle, filledcircle, triangle, filledtriangle
pairs	{ <i>inherited</i> }	none, solid, dashed, dotted, dotdashed, dotdot-dashed, dotdotdotdashed, yhisto, xhisto, filledyhisto, filledxhisto, surfaceyhisto, surfacexhisto
colour/color	{ <i>inherited</i> }	none, or any colour name from Section 8.1
paint	{ <i>inherited</i> }	no or yes
texture	{ <i>inherited</i> }	Any texture from Section 8.2
dataformat	{ <i>inherited</i> }	xandy, yonly, xonly
dashlength	{ <i>inherited</i> }	any <i>distance</i>
linewidth	{ <i>inherited</i> }	any <i>distance</i>
symbolsize	{ <i>inherited</i> }	any <i>distance</i>
symbollinewidth	{ <i>inherited</i> }	any <i>distance</i>
	{ <i>sequence</i> }	

Inherited means that the default value is taken from the @Graph option with the same name.

The right parameter of @Data contains a *sequence* of zero or more *expressions*. The xticks, yticks, and rticks options also are sequences, which may contain @ and labels as well as expressions. An *expression* is any of the following (operators are shown in decreasing precedence order, with the precedence, if relevant, at right):

<i>number</i>	
x (within xloop only)	
y (within yloop only)	
z (within zloop only)	
pi	
e	
{ <i>expression</i> }	
sqrt <i>expression</i>	40
abs <i>expression</i>	40
ceiling <i>expression</i>	40
floor <i>expression</i>	40
truncate <i>expression</i>	40
round <i>expression</i>	40
cos <i>expression</i>	40
sin <i>expression</i>	40
<i>expression</i> atan <i>expression</i>	39
<i>expression</i> exp <i>expression</i>	38
<i>expression</i> log <i>expression</i>	37
<i>expression</i> rand <i>expression</i>	36
<i>expression</i> * <i>expression</i>	35
<i>expression</i> / <i>expression</i>	34
<i>expression</i> idiv <i>expression</i>	34
<i>expression</i> mod <i>expression</i>	34
<i>expression</i> – <i>expression</i>	33
– <i>expression</i>	33
<i>expression</i> + <i>expression</i>	32
+ <i>expression</i>	32
if cond { <i>boolean</i> } then { <i>expression</i> } else { <i>expression</i> }	

A – immediately followed by a digit or decimal point is always taken to be a minus sign, never a subtraction. The left parameter of exp and log is the base of the exponentiation and logarithm respectively; idiv is integer division; and rand returns a uniform random integer lying between its two parameters (inclusive). Now a *sequence* is zero or more of the following:

@	(within xticks, yticks, and rticks only)
(<i>label</i>)	(within xticks, yticks, and rticks only)
<i>expression</i>	
xloop from { <i>expression</i> } to { <i>expression</i> } by { <i>expression</i> } do { <i>sequence</i> }	
yloop from { <i>expression</i> } to { <i>expression</i> } by { <i>expression</i> } do { <i>sequence</i> }	
zloop from { <i>expression</i> } to { <i>expression</i> } by { <i>expression</i> } do { <i>sequence</i> }	
if cond { <i>boolean</i> } then { <i>sequence</i> } else { <i>sequence</i> }	

The by part of the loop symbols is optional with default value 1; the else part of if is optional with default value equal to the empty sequence. A *boolean* is any one of the following things, again shown in decreasing precedence order, with the precedence at right:

<code>true</code>	
<code>false</code>	
<code>{ boolean }</code>	
<code>expression = expression</code>	30
<code>expression != expression</code>	30
<code>expression < expression</code>	30
<code>expression <= expression</code>	30
<code>expression > expression</code>	30
<code>expression >= expression</code>	30
<code>not boolean</code>	25
<code>boolean and boolean</code>	24
<code>boolean xor boolean</code>	23
<code>boolean or boolean</code>	22
<code>if cond { boolean } then { boolean } else { boolean }</code>	

Chapter 11. Pie Graphs

This chapter describes how to draw pie graphs, using the @Pie symbol. For example,

```
@Pie
{
  @Slice
  weight { 20 }
  label { Admin (20%) }
  @Slice
  weight { 40 }
  paint { green }
  label { Research (40%) }
  @Slice
  weight { 40 }
  paint { lightred }
  label { Teaching (40%) }
}
```

produces the pie graph

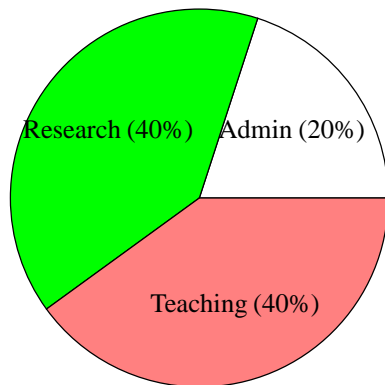

This example shows off most of what @Pie can do.

11.1. Introduction

The Lout definitions for pie graph formatting are kept in a file called `pie`, which you must include at the start of your document if you want pie graphs, like this:

```
@SysInclude { pie }
@SysInclude { doc }
@Doc @Text @Begin
...
@End @Text
```

Setup files for specialized packages, such as `pie`, should be included before the main setup file. Once this is done, the `@Pie` symbol used below will then be available for use anywhere within your document. As usual in Lout, the `@Pie` symbol produces an object which may appear anywhere at all – in a centred display, for example, or in a figure, or as an entry in a table.

A pie graph is made by a `@Pie` symbol enclosing a sequence of `@Slice` symbols. These `@Slice` symbols and their options are the only things that may appear inside the `@Pie` symbol.

Every option of `@Slice` is also an option of `@Pie`. Giving a value to such an option at `@Pie` will make that the default value for every `@Slice`. For example, you can write

```
@Pie
  weight { 20 }
{
  ...
}
```

to give every slice a weight (angular extent) of 20. If all but a few slices have the same weight, you can still do this, just giving a `weight` option to the exceptional slices.

Furthermore, every option of `@Pie` appears in the setup file, and giving a value to an option there makes that value the default value for every `@Pie` in your document. For example, if you want every slice of every pie to be light red, you can set the `paint` option in the setup file to `lightred`, and all your slices will be painted this colour unless you override the setup file value by giving `paint` options to some pies or slices.

See Section 4.1 to find out how to make your own copy of the setup file, perhaps calling it `mypie`, and change some options within it. Your document would then typically start like this:

```
@Include { mypie }
@SysInclude { doc }
@Doc @Text @Begin
...
@end @Text
```

and by changing options within file `mypie` you can affect every pie graph in your document.

11.2. Changing the appearance of slices

The `@Slice` symbol has options for controlling the appearance of the slice it makes:

```
@Slice
  weight { 10 }
  paint { none }
  texture { solid }
  outlinestyle { solid }
  outlinedashlength { 0.2f }
  outlinewidth { thin }
  detach { no }
```

This example shows the default values of the options.

The `weight` option is the weight (angular extent) of the slice. By default, the total weight of the complete pie graph is 100, so a slice of weight 10, say, would occupy 10% of the pie area, or in other words an angular extent of $(10/100) \times 360$ degrees. You can change the *total* weight by setting an option to the `@Pie` symbol:

```
@Pie
  totalweight { 360 }
```

The value 360 would be useful if you wanted your weights to correspond with degrees. It would be good to get `@Pie` to add up all the weights of its constituent slices and use that for the total weight, but problems behind the scenes prevent this. As it is, if the total weight of all slices is less than `totalweight`, the leftover angular extent will be blank; and if it exceeds `totalweight`, later slices will overstrike earlier ones.

The `paint` option defines the colour of the interior of the slice. Any colour acceptable to the `@Colour` symbol (Section 8.1) is allowed, plus the default value `none`, meaning no paint. As always, alongside the `paint` option there is a `texture` option:

```
@Pie
  paint { grey }
{
  @Slice
    weight { 20 }
    texture { striped }
    label { Admin (20%) }
  @Slice
    weight { 40 }
    texture { striped angle { 45d } }
    label { Research (40%) }
  @Slice
    weight { 40 }
    texture { striped angle { 90d } }
    label { Teaching (40%) }
}
```

produces

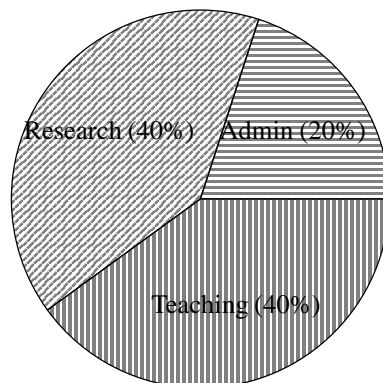

Textures might work better in black and white prints.

The next three options affect the outline drawn around each slice. The `outlinestyle` option may be `solid` (the default) which draws a solid line, `dashed` which draws a dashed line, `cdashed` which draws a dashed line with half-size dashes at the ends (this often looks better than `dashed`), `dotted` which draws a dotted line, and `noline` which draws no outline at all. The `outlinedashlength` option determines the dash length if `outlinestyle` is `dashed` or `cdashed`, and the distance between dots if `outlinestyle` is `dotted`. The length will be varied a little to ensure that the dashes or dots fit evenly on each segment of the outline. The `outlinewidth` option determines the width of the outline, or the diameter of the dots if `outlinestyle` is `dotted`.

You can give three values to `outlinestyle`, like this:

```
@Pie
{ red @Colour @Slice
  weight { 75 }
  outlinestyle { dashed cdashed dotted }
  label { Bad debts }
}
```

and the first will apply to the first straight segment, the second to the curved segment, and the third to the second straight segment:

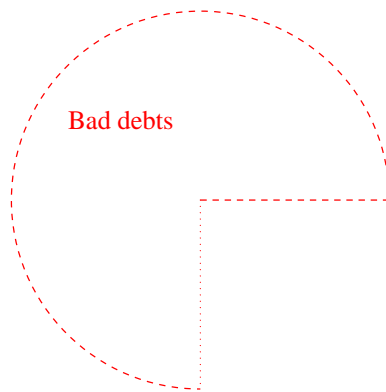

There is no option to change the colour of the outline, but you can change the colour of the whole slice using the `@Colour` symbol from Section 8.1 as shown. It colours the label as well, but you can fix that by enclosing the contents of your label in another `@Colour` symbol if you need to.

The `detach` option pulls its slice radially out of the pie, without affecting any other slice:

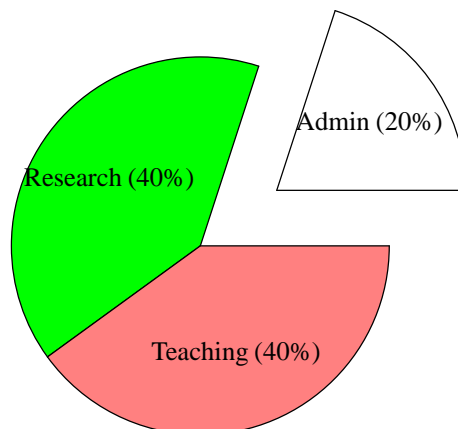

is produced by

```
@Pie
  aboveextra { 0.7c }
{
  @Slice
    detach { yes }
    weight { 20 }
    label { Admin (20%) }
  @Slice
    weight { 40 }
    paint { green }
    label { Research (40%) }
  @Slice
    weight { 40 }
    paint { lightred }
    label { Teaching (40%) }
}
```

We've used the `aboveextra` option (Section 11.3) to compensate for Lout's ignorance of where the slice actually ended up. The value of `detach` may be `no` (the default), `yes`, or any number, which defines the fraction of the pie radius that the slice is pulled out by. For example, `yes` is just another name for 0.5.

11.3. Changing the overall appearance of the pie graph

We've already seen that all `@Slice` options may be given to `@Pie` as well. In addition to those, `@Pie` has its own options that affect the overall appearance of the pie graph:

```
@Pie
  radius { 2.5c }
  initialangle { 0d }
  leftextra { 0c }
  rightextra { 0c }
  aboveextra { 0c }
  belowextra { 0c }
```

This example shows these options with their default values.

The `radius` option determines the radius of the pie graph. As shown, the default radius is 2.5 centimetres, giving a diameter of 5 centimetres.

The `initialangle` option determines the angle that the first slice begins at. Following mathematical convention, the default angle `0d` is directly to the right of the centre of the pie graph, and as the value of `initialangle` is increased the initial angle moves anticlockwise. The slices are placed in anticlockwise order immediately adjacent to each other. If you need a gap between two slices, use a slice with no outline, no paint, and no label.

Lout thinks that the whole pie graph occupies a square space tightly fitting around the given radius, as we can verify by drawing a box with zero margin around an example pie graph:

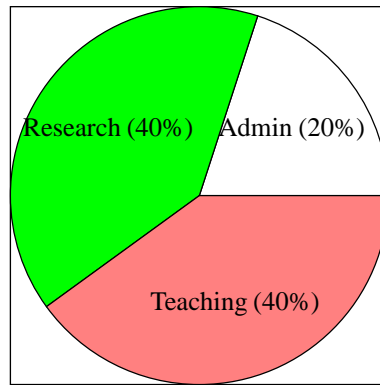

Detached slices (Section 11.2) and external labels (Section 11.5) can be printed outside this square region without Lout's knowledge, and this is likely to spoil the layout:

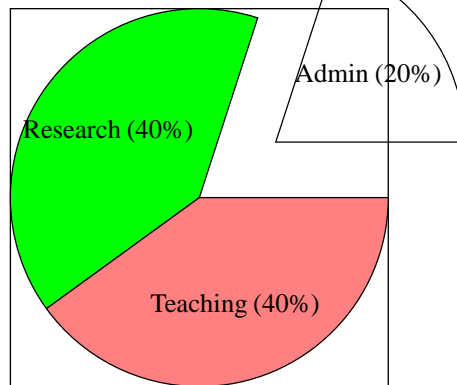

The `leftextra`, `rightextra`, `aboveextra`, and `belowextra` options are used to tell Lout to leave extra space to the left, right, above, and below, so as to correct these problems:

```
@Pie
  aboveextra { 0.7c }
```

We have not added extra space at the right as well, since we prefer to centre the pie graph horizontally without regard to detached slices. The result occupies 0.7 cm extra at the top:

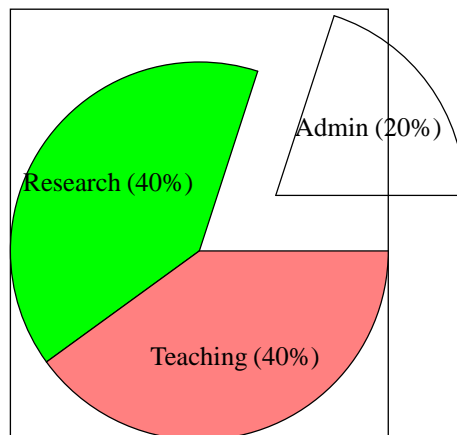

We'll see these options again when we come to external labels in Section 11.5.

11.4. Captions

There are options for placing captions left, right, above, and below the pie graph, following the pattern of the captions in @Graph:

```
@Pie
  leftcaption { At left }
  rightcaption { At right }
  abovecaption { This appears above }
  belowcaption { This appears below }
```

produces

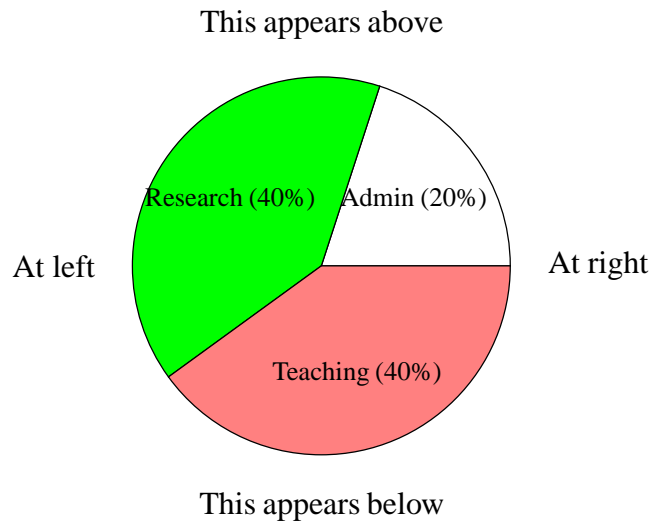

The captions may be arbitrary Lout objects, so may include equations, @Rotate, and so on. Each caption except rightcaption is printed in the clines @Break style, which means that multiple lines in one caption will be centred beneath each other. The rightcaption option uses the lines @Break style, in which the lines are left justified beneath each other.

There are options for controlling the amount of space between each caption and the pie graph. Here they are with their default values:

```
@Pie
  leftgap { 0.5c }
  rightgap { 0.5c }
  abovegap { 0.5c }
  belowgap { 0.5c }
```

These gaps are inserted only if the corresponding caption is non-empty. Lout knows exactly where captions are, and leaves space for them and their gaps, so it would be wrong to attempt to use the leftextra, rightextra, aboveextra, and belowextra options from Section 11.3 to allow for the space occupied by captions.

When a pie graph is to be presented as a centred display, it is usually best if the centring is done with respect to the pie alone, not the captions and labels. The hidecaptions option does this by making the left and right captions and gaps seem to Lout to have zero width:

```
@Pie
  hidecaptions { yes }
```

Actually `yes` has been made the default value, since the vast majority of pie graphs are centred displays. In the rare cases where this feature is not wanted (for example, if a pie graph appears as an entry in a table), use `hidecaptions { no }`.

11.5. Labels

Labels are short messages printed inside the slices, identifying them. We've already seen the `label` option, in which we place the label, which can be an arbitrary Lout object. In this section we'll show how to change the format and position of these labels.

For changing the format of a label there are four options:

```
@Slice
  labelfont { -2p }
  labelbreak { clines }
  labelmargin { 0.2f }
  labelformat { @Body }
```

This shows the default values of these options.

The `labelfont` option determines the font in which the label will be printed. The default value shown above calls for the current font to be used, two points smaller than it otherwise would have been. Any value acceptable to the `@Font` symbol from Section 1.6 is acceptable here, including changing the family and face.

The `labelbreak` option determines how paragraph breaking within the label will be carried out. Any value acceptable to the `@Break` symbol from Section 1.9 is acceptable here. The default value shown above causes each line of the label to be one line of the result, with each line centred with respect to the longest line.

The `labelmargin` option places a margin around the label. The default value shown makes a margin of width 0.2 times the current font size. This margin has no effect on the appearance or position of the label (in particular, it is drawn outside `labelformat` below, not inside). It is only needed for adjusting the appearance of figures, as described at the end of this section.

The `labelformat` option allows more radical changes to the label format. Its value may be an arbitrary object. Within it, the symbol `@Body` stands for the value of the label option:

```
@Slice
  labelformat { @ShadowBox @Body }
```

will cause the text of the label to appear within a shadow box. Of course, we could get this effect by placing these symbols in the label itself, like this:

```
@Slice
  label { @ShadowBox { Admin (20%) } }
```

However, like all `@Slice` options, `labelformat` may be given to `@Pie` as well, like this:

```
@Pie
  labelformat { @ShadowBox @Body }
```

and there it affects every label in the pie graph:

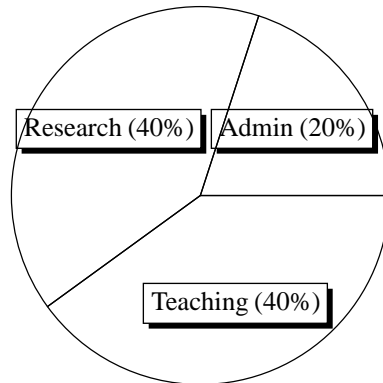

When the labels all have the same format, this is much faster and less error-prone than formatting each label independently, especially when experimenting with different formats.

Two options are available for changing the positions of labels:

```
@Slice
  labelradius { internal }
  labeladjust { 0c 0c }
```

Each label occupies a rectangular area, and these options determine the position of the centre of the rectangle.

The `labelradius` option determines how far the centre of the label is from the point of the slice (usually the same as the centre of the pie graph, but not when the slice is detached). The default value of `labelradius` shown above, `internal`, is a synonym for `0.6`, so it causes the centre of the label to appear 60% of the way from the point of the slice to its outside boundary. The angular position of the label centre will be halfway around the arc of the slice. No attempt is made to fit the label into the interior of the slice; it lands where these rules say irrespective of what might be overstruck when it does. It is printed after its slice's outline and paint, so it can't be hidden by them; but if it strays into the next slice it will be buried under any paint in that slice.

For fine adjustments, the `labeladjust` option may be used to move the label centre any distance in the x and y directions. For example,

```
@Slice
  labeladjust { 0.2c -0.1c }
```

will move the label centre 0.2 centimetres further to the right and 0.1 centimetres down from where it would otherwise have appeared.

The recommended procedure for getting internal labels to look good is to first try them without any adjustment. Next, consider rearranging the label layout. Our running example has poorly positioned labels, but they can be improved just by breaking each label over two lines:

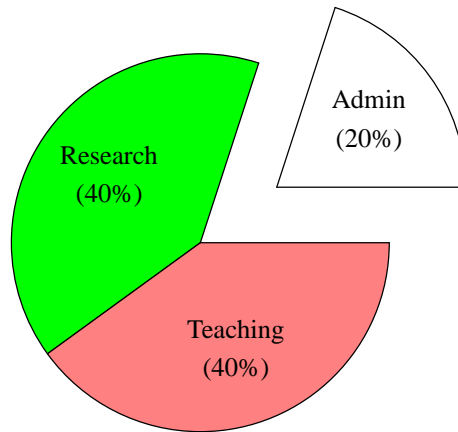

Finally, the `labeladjust` option is there as a last resort.

To get a label outside its slice, use

```
@Slice
  labelradius { external }
```

Again, `external` is just a synonym for the number 1.4, meaning that the label centre is to be placed 140% of the pie chart's radius away from the point of the slice. It can be replaced by any number.

Two issues arise when labels are placed externally. The first issue is that `Lout` does not know where these labels are being printed and so cannot leave space for them. Section 11.3 has already explained how to handle this problem using the `leftextra`, `rightextra`, `aboveextra`, and `belowextra` options of `@Pie`. Our running example, converted to external labels, might be entered like this:

```
@Pie
  abovecaption { Ideal breakdown of academic workload }
  labelradius { external }
  aboveextra { 0.7c }
  belowextra { 1.3c }
{
  @Slice
    detach { yes }
    weight { 20 }
    label { Admin @LLP (20%) }
  @Slice
    weight { 40 }
    paint { green }
    label { Research @LLP (40%) }
  @Slice
    weight { 40 }
    paint { lightred }
    label { Teaching @LLP (40%) }
}
```

which produces this:

Ideal breakdown of academic workload

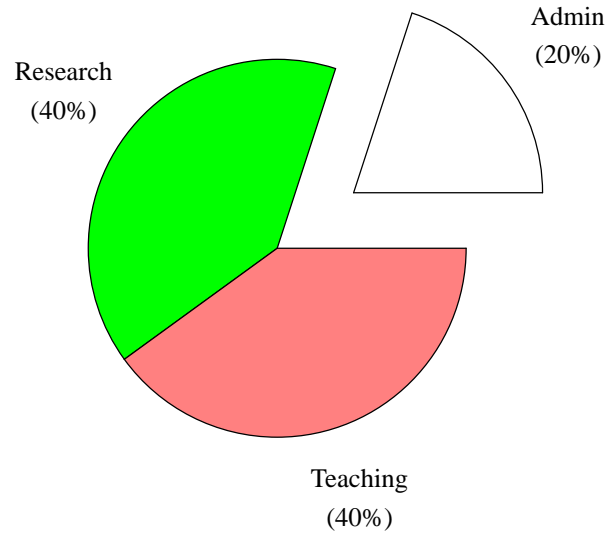

The amount of extra space to add has to be worked out by experiment. It can help to temporarily remove all captions and enclose the @Pie symbol in a box with zero margin:

```
@Box margin { 0i } @Pie ...
```

to show clearly how much space the extra options are covering.

The second issue raised by external labels is how to visually connect each label with its slice, when this seems necessary. @Pie can do this with short line segments that we will call *fingers*:

Ideal breakdown of academic workload

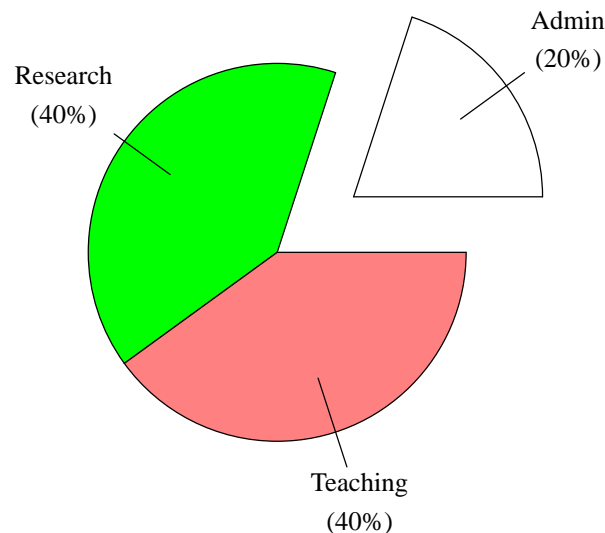

These were made by adding `finger { yes }` as another option to the @Pie symbol.

Each slice has several options which control the appearance of its own finger. Here is the full set, showing their default values:

```

@Slice
  finger { no }
  fingerstyle { solid }
  fingerdashlength { 0.2f }
  fingerwidth { thin }
  fingerradius { 0.7 }
  fingeradjust { 0c 0c }

```

The `finger` option may be `no` or `yes` and determines whether a finger will be drawn or not.

The `fingerstyle`, `fingerdashlength`, and `fingerwidth` options are exactly analogous to the `outlinestyle`, `outlinedashlength`, and `outlinewidth` options. They take the same range of values, and determine the style of the line segment drawn to make the finger (solid, dashed, etc.).

The `fingerradius` and `fingeradjust` options are exactly analogous to the `labelradius` and `labeladjust` options, except that instead of determining the position of the centre of the label they determine the position of the inner endpoint of the finger. The default values place it 70% of the way from the point of the slice to its outer edge. The *outer* endpoint of the finger always terminates on the bounding box of the label, with the line pointing through the centre of the label, and this cannot be changed, although the `labelmargin` option (see the start of this section) may be used to decrease or increase the margin around the label, thus causing the finger to terminate closer to the label or further away.

Fingers may have arrowheads on their inner ends:

```

@Pie
  labelradius { 1.6 }
  aboveextra { 2f }
  belowextra { 4f }
  finger { yes }
  fingerarrow { yes }
  fingerradius { 1 }
{
  @Slice
    detach { yes }
    weight { 20 }
    label { Admin @LLP (20%) }
  @Slice
    weight { 40 }
    paint { green }
    label { Research @LLP (40%) }
  @Slice
    weight { 40 }
    paint { lightred }
    label { Teaching @LLP (40%) }
}

```

produces

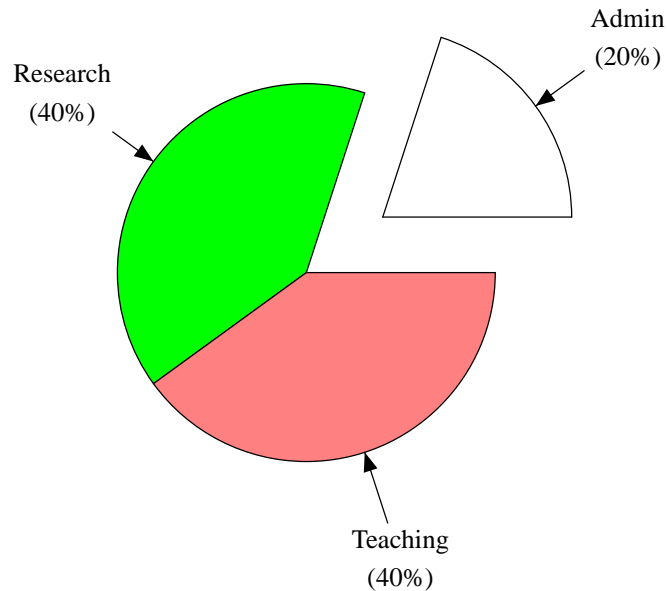

The point of the arrowhead coincides with the inner endpoint of the finger, so `fingerradius` would usually be set to 1 when arrowheads are used.

Although `@Pie` does not offer the elegant selection of arrowhead styles of `@Diag`, it is possible to change the length and width of the arrowheads with these options:

```
@Slice
  fingerarrowlength { 0.6f }
  fingerarrowwidth { 0.45f }
```

This example shows the default values of these options. These options may of course be given to `@Pie` and also in the setup file as usual.

11.6. Errors

Lout normally produces output that will print without mishap on any PostScript device. However, some of the options of `@Pie` and `@Slice` are passed through Lout without checking. Any errors in this material will not be detected until the file is printed.

When an error is detected, the offending page is printed up to the point where the error occurred, with a message nearby describing the error. Printing of the document is then aborted. The problem is usually easy to locate since it lies in whatever should have been printed next.

Like `@Diag` and `@Graph`, `@Pie` has a `save` option which causes the memory used by the pie graph to be reclaimed as soon as it is printed:

```
@Pie
  save { yes }
  ...
```

However `@Pie` uses very little memory and so this option is probably not going to be needed.

11.7. Summary

Here are the options of the @Pie symbol, with their default values and allowed values:

@Pie		
save	{ no }	no or yes
totalweight	{ 100 }	any positive number
radius	{ 2.5c }	any length
initialangle	{ 0d }	any angle (90d etc.)
leftextra	{ 0c }	any length
rightextra	{ 0c }	any length
aboveextra	{ 0c }	any length
belowextra	{ 0c }	any length
leftcaption	{ }	any Lout object
rightcaption	{ }	any Lout object
abovecaption	{ }	any Lout object
belowcaption	{ }	any Lout object
leftgap	{ 0.5c }	any length
rightgap	{ 0.5c }	any length
abovegap	{ 0.5c }	any length
belowgap	{ 0.5c }	any length
hidecaptions	{ yes }	no or yes
weight	{ 10 }	Any positive number
paint	{ none }	none or any colour (Section 8.1)
texture	{ solid }	Any texture (Section 8.2)
outlinestyle	{ solid }	solid, dashed, cdashed, dotted, or noline
outlinedashlength	{ 0.2f }	any length
outlinewidth	{ thin }	thin, medium, thick, or any length
detach	{ no }	no, yes, or any non-negative number
label	{ }	any Lout object
labelfont	{ -2p }	any font as given to @Font
labelbreak	{ clines }	any break style as given to @Break
labelmargin	{ 0.2f }	any length
labelformat	{ @Body }	any Lout object, usually including @Body
labelradius	{ internal }	internal, external, or any positive number
labeladjust	{ 0c 0c }	any point (pair of lengths)
finger	{ no }	no or yes
fingerstyle	{ solid }	solid, dashed, cdashed, dotted, or noline
fingerdashlength	{ 0.2f }	any length
fingerwidth	{ thin }	thin, medium, thick, or any length
fingerradius	{ 0.7 }	any positive number
fingeradjust	{ 0c 0c }	a point (pair of lengths)
fingerarrow	{ no }	no or yes
fingerarrowlength	{ 0.6f }	any length
fingerarrowwidth	{ 0.45f }	any length

The options from weight downwards are also the complete set of options of the @Slice symbol. The value of an option is the value given at the @Slice symbol, if any; otherwise, the value at the enclosing @Pie is used if any; if it is not given there, the setup file value is used.

Chapter 12. Computer Programs

This chapter describes how to typeset computer program text using Lout along with the `prg2lout` filter program, which is always installed wherever Lout is. The available languages are:

<i>Language name</i>	<i>Setup file name</i>	<i>Lout symbol</i>	<i>Default style</i>	<i>' ' escapes</i>
Blue	blue	@Blue	varying	Yes
C, C++	cprint	@CP	fixed	No
Eiffel	eiffel	@Eiffel	varying	Yes
Haskell	haskell	@Haskell	symbol	Yes
Java	java	@Java	fixed	No
Nonpareil	np	@Nonpareil	symbol	Yes
Perl	perl	@Perl	fixed	No
Pod	pod	@Pod	varying	No
Python	python	@Python	varying	No
RSL	rsl	@RSL	symbol	Yes
Ruby	ruby	@Ruby	fixed	No

C and C++ are handled together since, for formatting purposes, they differ only in that C++ has some additional keywords plus an extra way to make comments. Whenever we mention C from now on, we mean both C and C++. See Section 12.11 for more on Perl and its handmaiden Pod. The second to fifth columns of this table will be explained at various points later in this chapter.

It is possible to simply print out one or more program files independently of any document. Alternatively, the program text may be printed as part of a larger Lout document. Either way, Lout does not lay out the programs in the sense of choosing line breaks and indenting; it uses whatever line breaks and indenting you give to the program. What Lout does do is cope with characters in the program text that it would ordinarily either reject or interpret in some way (braces and so on), ensuring that you can include program texts with absolutely no modifications; plus, if you wish, Lout will print keywords in bold, identifiers in italics, add line numbers, etc.

It is relatively easy to add new languages, since you don't have to write executable code, just declare a lot of records describing your language. Consult the instructions at the top of file `prg2lout.c` if you want to try it yourself.

12.1. Typesetting computer programs independently of any document

Printing of program files independently of any document is done by the Unix pipeline

```
prg2lout -l language options files | lout -s > out.ps
```

where `language` stands for any one of the programming language names in the first column of the table above. As usual with Lout, the output will be a PostScript file. Each input file will begin on a new page of the output, starting with its name in bold type. The options are

- pstyle* Select a printing style (Section 12.2), either -*pfixed*, -*pvarying*, or -*psymbol*. The default value varies with the language, as shown in the fourth column of the table above.
- n* Do not print file names.
- ffont* Select a font family. The default is -*fCourier* for -*pfixed*, and -*fTimes* otherwise.
- vvsiz*e Select an inter-line spacing size in Lout units. The default is -*v1.1fx* meaning 1.1 times the font size measured from baseline to baseline.
- bnumber* Select a blank line scale factor, usually a number between 0.5 and 1.0, indicating the factor by which the usual amount of white space inserted to represent a blank line is to be reduced. The default is 1.0, meaning no reduction.
- Lnumber* Add line numbers to the print, starting with *number*, or 1 if *number* is omitted.
- N* Do not print line numbers at the start of blank lines.
- Sfile* Use *file* as the setup file for printing your language. This allows you to change all the options mentioned in subsequent sections, rather than just the few given here.

There are also -*t* and -*T* options for dealing with tab characters (Section 12.5).

12.2. Typesetting computer programs as part of a larger document

When the program texts are to be part of a larger Lout document, the procedure is somewhat different. You need to include the setup file appropriate to your language, like this:

```
@SysInclude { cprint }
@SysInclude { doc }
```

The *cprint* setup file includes everything needed to set up for C program formatting; for the other languages, consult the second column of the table at the start of this chapter.

The program texts within the Lout document are enclosed in braces preceded by the Lout symbol from the third column of the table, like this for the C language:

```
@IndentedDisplay @CP {
#include <stdio.h>

treeprint(struct tnode *p)    /* print tree p recursively */
{
    if (p != NULL) {
        treeprint(p->left);
        printf("%4d %s\n", p->count, p->word);
        treeprint(p->right);
    }
}
}
```

Although computer programs violate the rules of legal Lout input in many ways, these rules are suspended by the `@CP`, `@Eiffel` etc. symbols, allowing the program text to be incorporated with absolutely no modifications. The result is

```
#include <stdio.h>

treeprint(struct tnode *p)      /* print tree p recursively */
{
    if (p != NULL) {
        treeprint(p->left);
        printf("%4d %s\n", p->count, p->word);
        treeprint(p->right);
    }
}
```

We have chosen to use the `@IndentedDisplay` symbol from Section 2.1 to obtain an indented display, but in fact `@CP`, `@Eiffel` and the rest may appear anywhere at all: the result is an object in the usual way, which may go anywhere.

It is quite normal to include fragments of programs, particularly identifiers, within paragraphs; this is done in the obvious way:

```
Calling @CP { remove_cooling_rods() } without checking @CP { temp } first
is not recommended since it may cause the reactor to melt down.
```

Use `@OneCol @CP { ... }` (or `@OneCol @Eiffel { ... }` etc. for other languages) to prevent the program text being broken across two lines, if desired. Hyphenation is on by default in computer programs; however, the current language is changed from English or whatever to Programming, whose hyphenation rules permit hyphenation after an underscore character or between a preceding lower-case letter and a following upper-case letter, but not elsewhere.

In cases where the program text has unbalanced braces, it is necessary to use the alternative form `@CP @Begin ... @End @CP` (or the equivalent for other languages), so that Lout does not confuse program braces with Lout braces. In that case the program text must not contain `@End`; and in either case the program text must not include `@Include` or `@SysInclude` unless you are really including a file at that point (Section 12.9).

If your Lout document contains program texts in several languages, simply add one `@SysInclude` line for each of them and proceed as before. If your programming language is not currently supported, a viable alternative is

```
@F @Verbatim { ... }
```

This causes the text between braces to be set verbatim in a fixed-width font, as explained elsewhere in this guide. This method will not handle tab and formfeed characters very well. Again, use `@Verbatim @Begin ... @End @Verbatim` if your program text contains unbalanced braces.

12.3. Changing the appearance of a program

The @CP, @Eiffel etc. symbols have a number of options for changing the appearance of the printed program. These options are the same for all symbols, although their default values may vary. The style option changes the printing style; its value may be fixed (fixed-width font), varying (varying-width font), or symbol (varying-width font with mathematical symbols used for some operators). Its default value depends on the language, and may be found in the fourth column of the table at the start of this chapter. The example in the previous section was in fixed style; we can switch styles like this:

```
@CP
  style { varying }
{
#include <stdio.h>
treeprint(struct tnode *p)    /* print tree p recursively */
{
    if (p != NULL) {
        treeprint(p->left);
        printf("%4d %s\n", p->count, p->word);
        treeprint(p->right);
    }
}
}
```

The result in this case will be

```
#include <stdio.h>
treeprint(struct tnode *p)    /* print tree p recursively */
{
    if (p != NULL) {
        treeprint(p->left);
        printf("%4d %s\n", p->count, p->word);
        treeprint(p->right);
    }
}
```

If we use style { symbol } we get this:

```
#include <stdio.h>
treeprint(struct tnode *p)    /* print tree p recursively */
{
    if (p != NULL) {
        treeprint(p->left);
        printf("%4d %s\n", p->count, p->word);
        treeprint(p->right);
    }
}
```

with mathematical symbols replacing some of the operators.

The @CP, @Eiffel etc. symbols have additional options which allow a finer control over the style. Here they all are, with their default values:

```
@CP      [ or @Eiffel, @Blue, etc. ]
  pipe {}
  numbered { No }
  blanknumbered { Yes }
  style { fixed }
  font { Courier }
  size { -1.0p }
  line { 1.0vx }
  blanklinescale { 1.0 }
  space { lout }
  tabin { 8 }
  tabout { 8s }
  identifiers { Base }
  keywords { Base }
  operators { Base }
  numbers { Base }
  strings { Base }
  comments { Base }
{
  ...
}
```

Apart from pipe, numbered and blanknumbered, the default values shown are for style { fixed } only; the other styles have other defaults (Section 12.4). For the pipe option, see Section 12.9.

The value of numbered may be No (the default), Yes, or a number, and it determines whether or not line numbers are to be added, and if so the value of the first one. If numbered is Yes, then the blanknumbered option becomes relevant, and it determines whether blank lines are to receive line numbers or not. It has three acceptable values: Yes, the default value, meaning that blank lines are printed with line numbers, just like other lines; No, meaning that blank lines are not assigned line numbers; and NoPrint, meaning that blank lines are assigned line numbers but these are not printed, so that the line numbers printed before and after a blank line will differ by 2.

The style option is already familiar. Next comes font, which determines the font family to use, size, the font size to use, line, the inter-line spacing, blanklinescale, a scale factor by which the usual height of blank lines without printed line numbers is reduced (as in the option to the @Break symbol of the same name), and space, the spacing mode (as for the @Space symbol of Section 1.19). The default value of size asks for one point smaller than in the surrounding document; this was done to compensate for Courier's relatively large appearance compared to other fonts of the same nominal size.

The tabin and tabout options are the subject of Section 12.5. After them come six options giving the particular font faces in which to print identifiers, keywords, operators, numbers, strings, and comments. Base means the basic face; other commonly available choices are Slope and Bold. These options may all be set to different faces if desired.

12.4. Changing the appearance of all programs simultaneously

We have just seen that the @CP, @Eiffel etc. symbols have many options for changing the appearance of the program text. However, most people would not want to have a different style for every program text in their document; they want to define the style once at the start, and have all their program texts come out in that style without laboriously setting options on every symbol. You do this by copying the setup file and changing it.

For general information about how to make your own setup file, consult Section 4.1. The options that determine the default values are in the @Use clause which occupies most of the setup file. Here is part of the @Use clause from cprint:

```
@Use { @CPSetup
# pipe           {          }
# numbered       { No      }
# blanknumbered { Yes      }
# style          { fixed   }

# fixedfont      { Courier  }
# fixedsize      { -1.0p   }
# fixedline      { 1.0vx   }
# fixedblanklinescale { 1.0    }
# fixedspace     { lout    }
# fixedtabin     { 8       }
# fixedtabout    { 8s     }

# fixedidentifiers { Base   }
# fixedkeywords   { Base   }
# fixedoperators  { Base   }
# fixednumbers    { Base   }
# fixedstrings    { Base   }
# fixedcomments   { Base   }
# fixedlinenumbers { Base   }

# fixedidentifiersformat { @Body }
# fixedkeywordsformat   { @Body }
# fixedoperatorsformat  { @Body }
# fixednumbersformat    { @Body }
# fixedstringsformat    { @Body }
# fixedcommentsformat   { @Body }
# fixedlinenumbersformat { @Body }
}
```

The pipe option will be explained in Section 12.9. The options whose name begins with fixed apply only when style is fixed; there are corresponding options, not shown, which apply when style is varying and symbol.

This extract shows that the default value of numbered is No, of blanknumbered is Yes,

and of style is fixed. It also shows the default font family, font face, font size, line spacing, blank line scale factor, spacing mode, and tab settings when the style is fixed. The font family name for fixed style is Courier, but for the other styles (not shown) it is empty. This causes the fixed style to always switch to Courier, and the other styles to use the same font family as in the surrounding document.

The options from `fixedidentifiers` to `fixedlinenumbers` allow you to set the font face to use for each of these parts of your program. People who want fixed-width fonts do not usually want very exciting font faces either, so the default values above are all `Base`, but for the `varying` and `symbol` styles, the default identifier face is `Slope`, the default keyword face is `Bold`, and so on. You can actually give a family name before the face name in these options, allowing you to switch font families for different parts of the program if you wish.

The `fixedidentifiersformat` option allows you to make a more radical change to the format of identifiers than just the font. Within this option, `@Body` stands for the identifier being formatted, and by applying Lout symbols to it, you apply them to every identifier. For example,

```
fixedidentifiersformat { red @Colour @Body }
```

will cause identifiers to be printed red.¹ If you do use exotic formats, remember that in some programming languages, comments and even strings may occupy more than one line: `@Box`, for example, will give a logical but probably unwanted result when formatting a multi-line string.

As always with setup files, to change a default value, delete the preceding `#` and change the part between braces. For example, suppose you are happy with `fixed` except that you want bold keywords. Then one line needs to be changed, to

```
fixedkeywords { Bold }
```

Or suppose you like `varying` as it stands, but would like it to be the default style rather than `fixed`. Again, only one line needs to be changed, to `style { varying }`.

It is probably not a good idea to change the default value of `numbered` to `Yes`, because small fragments of code within paragraphs will then get line numbers as well as large displayed programs. If you do have many large numbered programs as well as small fragments, a better approach would be to place

```
import @CPSsetup
macro @NCP { @CP numbered { Yes } }
```

(or the equivalent for your language) in your `mydefs` file, so that you can type `@NCP` instead of `@CP numbered { Yes }`. On the other hand, it is quite safe to change `blanknumbered` to `No` or `NoPrint` in the setup file; this will cause line numbers to be omitted from blank lines whenever there happen to be line numbers.

The setup files for the other languages are identical to this one, except that the symbol after

¹`@Colour` is not a Lout primitive like, say, `@Font`; it is defined when you write `@SysInclude { doc }` or the equivalent for the other document types. This is true of quite a few generally useful symbols, including `@Box` and `@I`. If you want to use these symbols here, you must include your setup file *after* `@SysInclude { doc }` or whatever, the reverse of the usual arrangement, so that they are defined before Lout reads your setup file. This is always done when formatting programs independently of any document, so you can use these symbols in a setup file given by a `-S` command line flag.

@Use is different, and some of the default values may be different. Changing an option affects only the language of that setup file; if you have multiple languages you can have multiple setup files and change their options quite independently of each other.

12.5. Dealing with tab characters in programs

Tab characters provide a convenient way to indent and align parts of computer programs. With care, this alignment can be preserved in the final print even with varying-width fonts.

The distance between two tab stops in the program text is by default taken to be 8 characters, which is standard for Unix. This can be changed with the `tabin` option. For example,

```
@CP tabin { 4 }
```

informs Lout that tab stops occur every 4 characters in the program text. All the symbols (@CP, @Eiffel, etc.) and their setup files have this option and the next; but to save repetition we will stick with C for the rest of this section.

The distance between two tab stops on the printed page is quite a different thing, and it is determined by the value of the `tabout` option, which must be a Lout length. For example,

```
@CP tabout { 0.5i }
```

requests that tab stops be placed at half-inch intervals. In other words, a distance of one tab stop in the program text will be equivalent to a distance of half an inch on the printed page. For example,

```
@CP style { varying } tabout { 3f } numbered { Yes }
```

might produce the following, where tab characters in the program text have been used for indenting and also to align the comments:

```
1      struct tnode {                /* the basic node */
2          char *word;                /* points to the text */
3          int count;                /* number of occurrences */
4          struct tnode *left;      /* left child */
5          struct tnode *right;     /* right child */
6      };
```

We've used `numbered { Yes }` to demonstrate that the features for dealing with tabs work even with line numbers. The value `3f` means three times the current font size, and it is the default value of `tabout` for the varying and symbol styles (Section 12.4). In a 12 point font this is 36 points, or half an inch.

If `tabout` is too small, there is a danger that the alignment might fail. For example,

```
@CP style { varying } tabout { 0.2i }
```

produces

```

struct node { /* the basic node */
    char *word; /* points to the text */
    int count; /* number of occurrences */
    struct tnode *left; /* left child */
    struct tnode *right; /* right child */
};

```

given the same C text as the previous example. The problem here is that we are asking for /* to appear four tab stops or 0.8 inches from the left edge, and yet the material to its left on the line is wider than this. This causes /* to be shifted further to the right than expected, and the alignment is lost. The only solution is to increase `tabout`.

When typesetting computer program texts independently of any document, there are `-t` and `-T` options to the `prg2lout` program equivalent to `tabin` and `tabout` respectively. For example, `-T0.5i` produces a half-inch tab width.

12.6. Dealing with formfeed characters in programs

The formfeed (Control-L) character is traditionally taken to be a request to start a new page. This is explicitly recognized by the formal definition of the C language and many others, which treat this character as white space from a language point of view, with the understanding that it will cause a page break when printed.

There are no `prg2lout` options for dealing with formfeed characters. They will be converted into `@NP` (new page) symbols, causing a new page or column to be begun in the printing.

Whether formfeed characters end their line or not is a problem. Consider this example, where `^L` stands for one formfeed character:

```

abc
def^Lghi
jhk

```

How many lines does this example contain? Your text editor would probably say ‘three’, but when you print it you will see four. It is not desirable to have printed programs (especially those with line numbers attached) disagreeing with text editors about line numbers. The solution adopted by `prg2lout` to this problem is to treat the formfeed character as including a newline, but to assign the same line number to both parts of the original line (the parts before and after the formfeed). If the part after the formfeed is empty (that is, if the formfeed character is immediately followed by a newline or another formfeed), and if the formfeed is not inside any lexical unit, then the empty line after the formfeed will not be printed at all.

The most common case is that of a formfeed character, outside any lexical unit, on a line by itself. Let’s see what this rule produces in the following example of this case:

```

abc
def
^L
ghi

```

There will be one blank line numbered 3 at the end of the first page, and a line numbered 4 and containing ghi at the start of the next page. The blank line is a necessity, at least when lines are being numbered, because we want the last line in the example to be numbered 4 to agree with text editors, but we don't want the line numbers on our print to skip from 2 on the first page to 4 on the second, because that would make readers anxious about the apparently missing line 3. If you don't want that empty line, move the formfeed character to the end of the preceding line.

12.7. Embedding Lout commands within program comments

It is possible to embed Lout text inside program comments. How this is done could in principle vary from language to language, but in every language supported so far it is done by starting off the comment with an @ character. If the language has several ways to get a comment, this will work every way. The entire comment after the @ character should then be Lout text. For example, to force Lout to start a new page at some point within a C program, place

```
/*@ @NP */
```

at that point. (In this case you can also simply include a formfeed character without any comment; see Section 12.6 for more on this.) Or, to make a heading in an Eiffel program, do this:

```
--@ @Display @Heading { treeprint }
```

(Eiffel comments begin with -- and end at the end of the line.) Other possible uses for this feature include index entries and margin notes. Incredible as it may seem, you can even write

```
/*@ @CD @Heading { Function @CP { treeprint() } } */
```

with @CP and C code inside the Lout code inside the C code. You probably can't go further, however, at least not in C, since that would require a C comment inside a C comment.

It's possible to get quite long Lout insertions, with a bit of care. For example, here's how to get a filled paragraph of text into a computer program:

```
@Eiffel {
--@@ID ragged @Break {
--@This program is free software; you can redistribute
--@it and"/"or modify it under the terms of the
--@@B { GNU General Public License } as published by
--@the Free Software Foundation; either Version 2, or
--@(at your option) any later version.
--@}
```

```
launch(x: APPLICATION) is
  -- launch the application
  deferred
}
```

produces

This program is free software; you can redistribute it and/or modify it under the terms of the **GNU General Public License** as published by the Free Software Foundation; either Version 2, or (at your option) any later version.

```
launch(x: APPLICATION) is
  -- launch the application
deferred
```

This example relies on the fact that prg2lout passes escape comments like these through to Lout absolutely untouched. Notice the use of both a display symbol (`@ID`) and a change to the break style (ragged `@Break`). If the change of break style had been omitted, the break style of the surrounding program, lines `@Break`, would have been applied to the displayed paragraph. The display symbol is needed because without it the paragraph would be an integral part of the surrounding program (which is actually considered by Lout to be one paragraph), making the ragged `@Break` ineffective since you can't change the paragraph style in the middle of a paragraph.

Clearly, use of such escape comments in conjunction with line numbers is going to be problematic. No promise is made that the result of doing that will make sense.

12.8. Embedding program text within program comments

The standard reference for the Eiffel language [8] specifies that identifiers within comments may or should be enclosed in ‘ and ’ so that they may be noticed and printed in an italic font:

```
@ID @Eiffel {
deposit(amount: REAL) is
  -- deposit 'amount' dollars
}
```

produces

```
deposit(amount: REAL) is
  -- deposit amount dollars
```

This has been generalized in Lout: arbitrary text within an Eiffel comment between ‘ and ’ will be treated as Eiffel text and printed accordingly. Some other languages may also offer this feature: see the fifth column of the table at the start of this chapter. In principle the precise means of getting it could vary from language to language, but the languages available at the moment either do not have it at all, or else they use ‘ and ’ like Eiffel.

On the subject of Eiffel, the Eiffel reference [8] has some quite detailed style guidelines, and these have been closely followed in the implementation of the `@Eiffel` symbol. In particular, `@Eiffel` prints dots larger than usual when they denote feature calls, as the example `account.deposit(20)` shows.

12.9. Reading and selecting program text from separate files

We have said that program text within `@CP { ... }` and the other symbols is passed directly to `prg2lout` for analysis. However, there is an exception. The program text may contain an `@Include` or `@SysInclude` command, which, as for the `@Verbatim` symbol (Section 1.17), causes `Lout` to take the program text from a file:

```
@Eiffel
{
  @Include { "/usr/staff/jeff/Eiffel/hash.e" }
}
```

The included file is not examined for balanced braces or `@End` or `@Include`; it is treated entirely verbatim and passed straight on to `prg2lout`. There may be several `@Include` commands, and any amount of program text as well, within `@CP { ... }` and the rest.

When including files in this way it often happens that only part of an actual program file is wanted for display. Rather than placing the wanted part in a separate file, which is error-prone and tedious when the program is changing, Unix users can use the `pipe` option to pipe the entire file through an arbitrary sequence of Unix commands, which may be used to make the wanted selection before the program text is passed to `prg2lout`.

For example, suppose that all your Eiffel routines begin with the routine name one tab stop from the left margin and end at the first following **end** indented two tab stops. Then

```
@Eiffel
  pipe { "sed -n /^.insert/,/^..end/p" }
{
  @Include { "/usr/staff/jeff/Eiffel/hash.e" }
}
```

will select just the *insert* routine from the `hash.e` file. Assuming that your program text has been laid out in a disciplined manner, every line of the selection will begin with a tab character that is not wanted in this display, so an even better pipe is

```
@Eiffel
  pipe { "sed -n /^.insert/,/^..end/p | cut -c2-" }
{
  @Include { "/usr/staff/jeff/Eiffel/hash.e" }
}
```

since it cuts away the unwanted tab characters. Unfortunately, we can't show the result of this on an actual example, since that would prevent this manual from being formatted on a non-Unix system.

When using `pipe` it is also possible to omit `@Include` and use the pipe to get the file as well as select from it:

```
@Eiffel pipe { "cat /usr/staff/jeff/Eiffel/hash.e | sed -n /^.insert/,/^..end/p | cut -c2-" } {}
```

This pipes nothing into the `cat` command, which does no harm.

12.10. Error messages

In order to understand the error messages produced by program printing, it is necessary to understand that Lout's first step when given a program text is to pass it to the separate `prg2lout` program for analysis. This separate program is the source of most of the error messages associated with program printing.

The `prg2lout` program is quite happy to format a fragment of a computer program: there is no need to supply a complete routine, or a complete statement, or any such thing. However, it will complain if you supply only a fragment of one lexical unit, such as a comment or string without its terminating delimiter. It will also complain if there is a character that cannot be classified as part of an identifier, number, etc. according to the rules of the language as they have been given to `prg2lout` by the implementer. Irrespective of the language rules, `prg2lout` always interprets spaces, tabs, newlines, and formfeed characters in the usual way.

If an error message is generated by `prg2lout`, it will contain a line and column number counting from the start of the program text involved. Lout will precede this error message with a file name, line number, and column number pointing to the Lout symbol (`@CP`, `@Eiffel` etc.) whose program text caused the error message, like this:

```
lout file "prg_tabs" (from "prg" line 96, from "all" line 46):
  56,23: prg2lout 2,1: program text ended within comment
```

This is an actual message produced when formatting this chapter. The program text in question has only one line, containing an incomplete comment, so when `prg2lout` tried to start the second line and found nothing, it complained as shown. In general, then, you have to add `prg2lout`'s line number to Lout's line number, and use some initiative, to find the precise point of the problem.

12.11. Notes on Perl and Pod

The Perl programming language¹ is quite a difficult one for the `prg2lout` program to deal with, and our boast that programs can be included with 'absolutely no modifications' is not quite true for Perl.

Here is the complete list of problem areas. In most cases their effect is to get the formatting wrong over a short region, which is not perhaps so disastrous; and it should be easy to modify your Perl program without changing its meaning, to work around these problems. After all, in Perl there is always more than one way to do it.

1. *Here-documents* such as

```
<<"EOF"
  These lines will be read as though
  enclosed in double quotes
  EOF
```

will be handled correctly only if the string appearing immediately after the `<<` operator (that is, the string used to terminate the here-document) is one of `EOF`, `EOT`, `END`, and the empty

¹My thanks to Mark Summerfield for help with Perl and Pod.

string, all optionally enclosed in quotes of any of the three kinds. If this condition is not met, then the here-document will be treated as Perl program text. If the condition is met, there is still another problem: the << symbol and everything after it on the same line will be treated (incorrectly) as a string. The worst consequence of this is that stacked here-documents will not be printed properly.

2. When `prg2lout` is scanning the program text looking for the beginning of a lexical unit, it may come upon a `/` character, and this *initial* `/` (not subsequent ones in the same lexical unit) it finds difficult to interpret, since it may be the beginning of a regular expression, to be formatted like a string, or it may be a complete lexical unit denoting division. The program chooses the regular expression (or equivalently, string) interpretation if the `/` character is immediately preceded by `q`, `qq`, `qx`, `qw`, `qr`, `m`, `s`, `y`, or `tr`. It also chooses the regular expression interpretation if the `/` character appears at the start of a line, or if it is immediately preceded by zero, one, or two space or tab characters, which are themselves immediately preceded by a complete lexical unit which is one of `(`, `=`, `=~`, `!~`, `split`, `if`, `and`, `&&`, `or`, `||`, `not`, `!`, `unless`, `for`, `foreach`, and `while`. Otherwise it chooses the division interpretation. In the rare cases where this rule fails, you can force `prg2lout` to choose the regular expression interpretation by placing an `m` in front of the initial `/` (this does not change the meaning of the program), and you can force the division interpretation by placing at least three spaces before the `/` character.
3. Substitution expressions, even such lexically complex ones as `s{ {@D} } [{@I}]`, are handled correctly. However, `prg2lout` does not understand that the letters `gimosx` in any combination appearing immediately after a substitution expression are part of it; it treats them as the start of a new lexical unit. This new unit will usually be taken to be an identifier, which is harmless enough, but occasionally it is taken to be something else. For example, in

```
s///s;
```

the trailing `s` will be mistaken for the start of a new substitution expression, with `;` delimiting the first pattern. This particular example can be fixed by inserting a space before the semicolon.

Further work may eliminate some of these problems.

The Pod language is used by Perl programmers for creating documentation, and may be found within Perl programs or standing alone. Lout supports both arrangements without any special action by the user. At the beginning of the perl setup line, the following line has been placed:

```
@SysInclude { pod }
```

Thus, asking for Perl always gives you Pod as well. If you are using your own setup files for both languages, it is probably better to break this connection by deleting this line from your copy of the perl setup file and placing

```
@Include { mypod }
@Include { myperl }
```

at the start of your document in the usual way.

Because Pod is a documentation language rather than a programming language, the setup file options listed in Section 12.4 do not really apply. So for Pod only these have been discarded and replaced by a completely different set of options, controlling such things as the size of headings and the gaps between list items, which you can find documented in the pod setup file.

If you ask for line numbers on a Pod program, or on a Perl program that contains Pod, any text blocks in the Pod that would otherwise have appeared as filled paragraphs will come out with the line breaks in the source respected, and lines numbered accordingly. Because `prg2lout` attaches line numbers before Lout breaks paragraphs, it is not possible to number the lines after paragraph breaking.

Owing to problems behind the scenes, if a Pod inclusion in a Perl program has unbalanced braces, `prg2lout` is forced to insert braces into the Pod text to make them balance. It will insert a left brace directly before any unbalanced right brace, and it will insert right braces at the end of the Pod inclusion to balance any preceding unbalanced left braces. It will tell you if it has to do this. This problem does not afflict Pod when used as a separate language.

Chapter 13. Pascal and Modula-2 Programs

There is a @Pas symbol for printing Pascal programs [1]. No attempt is made to follow any particular printing standard; the design simply reflects this author's taste. To use @Pas, place @SysInclude { pas } at the start of your document in the usual way. A Pascal program or program fragment is entered like this:

```
@ID @Pas {
procedure PriDelete(x: PriEntry; var Q: PriorityQueue);
  var i: integer;
begin
  with Q^ do begin
    size := size - 1;
    if x^.back <= size then
      begin
        i := x^.back;
        A[i] := A[size + 1];
        A[i]^back := i;
        PriAddRoot(i, Q);
        PriAddLeaf(i, Q)
      end
    end
  end;
}
```

This produces

```
procedure PriDelete(x: PriEntry; var Q: PriorityQueue);
  var i: integer;
begin
  with Q↑ do begin
    size := size - 1;
    if x↑.back ≤ size then
      begin
        i := x↑.back;
        A[i] := A[size + 1];
        A[i]↑.back := i;
        PriAddRoot(i, Q);
        PriAddLeaf(i, Q)
      end
    end
  end;

```

Blank lines, line breaks, indents and spaces in the input are respected, with a tab being considered equal to eight spaces. @Pas can also be used within a paragraph to produce a fragment like $A[i..j]$. Use @OneCol @Pas { ... } to prevent the result from breaking over two lines.

@Pas does not attempt to rearrange the program in any way. Each item is simply printed according to the following plan:

and	and	0	0
array	array	1	1
begin	begin	2	2
case	case	3	3
const	const	4	4
div	div	5	5
do	do	6	6
downto	downto	7	7
else	else	8	8
end	end	9	9
file	file	.	.
for	for	,	,
forward	forward	:	:
function	function	;	;
goto	goto	,	,
if	if	'	'
in	in	+	+
label	label	-	-
mod	mod	*	*
nil	nil	/	/
not	not	((
of	of))
or	or	[[
otherwise	otherwise]]
packed	packed	^	↑
procedure	procedure
program	program	=	=
record	record	<	<
repeat	repeat	>	>
set	set	<>	≠
then	then	<=	≤
to	to	>=	≥
type	type	:=	:=
until	until		
var	var		
while	while		
with	with		

Anything not mentioned here will appear in italic font.

Unlike the @CP symbol from the previous chapter, the @Pas symbol is a quick-and-dirty

production which does not offer you any options, or indeed attempt to solve every problem of Pascal formatting. In particular, Pascal strings need attention before formatting by @Pas. Their interiors are best enclosed in double quotes to prevent the above transformations from occurring inside them. Any \ or " characters inside strings will need to be replaced by \\ and \" respectively, and the opening quote should be replaced by '.

Similar remarks apply to Pascal comments; don't forget that { and } must be enclosed in double quotes. Alternatively, a @Com symbol can be placed in front of a comment enclosed in braces. It will add literal braces:

```
@Com { A Pascal comment }
```

has result

```
{ A Pascal comment }
```

It may still be necessary to enclose the interior in double quotes.

There is a @Modula symbol which allows you to format Modula-2 programs in the same way as @Pas does for Pascal. You get it via @SysInclude { modula }, and once again it is a quick-and-dirty production.

Appendix A. Lout Quick Reference Guide

1. Running Lout

lout filename > postscript.ps

2. Ordinary documents (simple form)

```
@SysInclude { doc }
@Doc @Text @Begin
...
@end @Text
```

3. Ordinary documents (full form)

```
@SysInclude { doc }
@Document
  @InitialFont { Times Base 12p }
  @InitialBreak { adjust 1.2fx hyphen }
  @InitialLanguage { English }
  @PageHeaders { Simple }
  @FirstPageNumber { 1 }
  @ColumnNumber { 1 }
  @PageOrientation { Portrait }
//
@Text @Begin
...
@BeginSections
@Section ... @End @Section
@endSections
@end @Text
```

4. Technical reports

```
@SysInclude { report }
@Report
  @Title { ... }
  @Author { ... }
  @Institution { ... }
  @DateLine { No }
  @CoverSheet { Yes }
  @InitialFont { Times Base 12p }
  @InitialBreak { adjust 1.2fx hyphen }
  @InitialLanguage { English }
  @PageHeaders { Simple }
  @FirstPageNumber { 1 }
  @ColumnNumber { 1 }
  @Abstract { ... }
//
@Section ... @End @Section
@Appendix ... @End @Appendix
```

5. Large-scale structure symbols

```
@Section
  @Title { ... }
  @RunningTitle { ... }
  @Tag { ... }
@Begin
@PP
...
@end @Section

@Section / @SubSection / @SubSubSection
@Appendix / @SubAppendix / @SubSubAppendix
@BeginSubSections ... @EndSubSections if inner.
```

6. Cross references

```
@Tag { foo }           @PageOf foo
@PageMark foo         @NumberOf foo
```

7. Font changes

```
@B { bold font }       @I { italic font }
@BI { bold-italic font } @R { Roman font }
@S { small-caps font } @F { fixed-width font }
                        @II { italic bold or Roman }
```

```
{ family face size } @Font { ... }
```

```
Times Helvetica Courier ...
Base Slope Bold BoldSlope ...
10p 12p +2p -2p 2.0f ...
```

8. Paragraph breaking styles

```
{ breakstyle linesep hyphen } @Break { ... }
```

```
adjust ragged lines clines ...
1.2fx 2vx 0.9vx ...
hyphen nohyphen
```

9. New paragraph and new page

```
@PP   Plain paragraph
@LP   Left paragraph
@LLP  New line
@DP   Display paragraph
@NP   New page
@CNP  Conditional new page
```

10. Displays and headings

@CD @Heading { A centred heading }
 @ID { An indented display }

@D @Display
 @LD @LeftDisplay
 @ID @IndentedDisplay
 @QD @QuotedDisplay
 @CD @CentredDisplay
 @CenteredDisplay
 @RightDisplay

11. Lists

@List
 @ListItem { A list item }
 @ListItem { Another list item }
 @EndList

@L @List
 @LL @LeftList
 @IL @IndentedList
 @QL @QuotedList
 @CL @CentredList
 @CenteredList
 @NL @NumberedList
 @RL @RomanList
 @UCRL @UCRomanList
 @AL @AlphaList
 @UCAL @UCAAlphaList
 @PNL @ParenNumberedList
 @PRL @ParenRomanList
 @PUCRL @ParenUCRomanList
 @PAL @ParenAlphaList
 @PUCAL @ParenUCAAlphaList
 @BL @BulletList
 @SL @StarList
 @DL @DashList

@TaggedList
 @TagItem { label } { A list item }
 @TagItem { label } { Another list item }
 @EndList

@TL @TaggedList
 @WTL @WideTaggedList
 @VWTL @VeryWideTaggedList

12. Footnotes, endnotes, margin notes

@FootNote { ... } @EndNote { ... }
 @LeftNote { ... } @RightNote { ... }
 @OuterNote { ... } @InnerNote { ... }

13. Floating figures and tables

@Figure @Table
 @Caption { ... } @Caption { ... }
 @Tag { ... } @Tag { ... }
 @Begin @Begin
 ...
 @End @Figure @End @Table

14. Tables

@SysInclude { tbl }
 @SysInclude { doc }
 ...
 @Tbl
 aformat { @Cell A | @Cell B }
 marginvertical { 0.5vx }
 {
 @Rowa
 A { ... }
 B { ... }
 @Rowa
 ...
 }

15. Equations

@SysInclude { eq }
 @SysInclude { doc }
 ...
 @Eq { sum from i=0 to n { r sup i over sqrt pi } }

16. Basic graphics

grey @Colour { ... }
 gray @Color { ... }
 @Box { ... }
 @CurveBox { ... }
 @ShadowBox { ... }
 60d @Rotate { ... }
 0.71 @Scale { ... }
 @QuotedDisplay @Scale { ... }
 @IncludeGraphic filename.eps

17. Miscellaneous

@Underline { will be underlined }
 @Date
 @Time
 German @Language { ... }
 # comment to end of line
 "#&/@^{|~" (enclose these characters in quotes)

Appendix B. Bypass Symbols

The ‘bypass’ symbols described in this appendix are intended to be used in Lout which is generated by computer programs. Their purpose is to bypass the Lout cross reference database, and so reduce the number of passes needed to finalise a document. These symbols are not intended to be used by people, because that would only lead back to the consistency problems that prompted the introduction of cross references in the first place.

To produce a bypass table of contents, set the `@MakeContents` setup file option to `Bypass` and use `@BypassContentsEntry` symbols at the outermost level just before the introduction or first chapter:

<code>@BypassContentsEntry</code>	
indent { 0f }	the indent, e.g. 0f, 2f, 4f ...
number { }	the section (etc.) number e.g. 5.2
title { }	the section (etc.) title e.g. Azaleas
pagenum { }	the page number e.g. @PageOf azaleas

For major entries such as chapters, use `@BypassMajorContentsEntry` with the same options. This increases the vertical spacing and uses bold font. When `@MakeContents` is `Bypass`, no contents entries will be produced automatically.

To bypass Lout’s automatic numbering of large-scale structure symbols, use the `@Bypass-Number` option:

```
@Section
  @Title { Azaleas }
  @Tag { azaleas }
  @BypassNumber { 5.2 }
```

...

Give the full ‘path number’ (5.2, B.3 or whatever) of the symbol. There is a `@BypassNumber` option for every symbol that has a `@Title` option and is usually assigned a number automatically by Lout, plus `@Figure`, `@Table`, and (since Version 3.36) the numbered display symbols. No changes to the setup file are required in order to use `@BypassNumber`, and it is permitted for some large-scale structure symbols to have this option and others not.

To produce a bypass reference list, set the `@MakeReferences` setup file option to `Bypass` and place reference entries at the end of the document, after the last chapter or other large-scale structure symbol but before any bypass index entries (see below), like this:

```
@BypassReference
  label { [Kin94a] }
  value { @RefPrint kingston1995lout.expert }
```

The two options are objects which become the label and value of the reference entry. The value

option can be any object, including an explicit reference; but `@RefPrint` does not introduce any cross-referencing delay if the `@Reference` symbols lie in a separate database file. No sorting or removal of duplicate entries will be done by Lout. When `@MakeReferences` is `Bypass`, `@Cite` and related symbols are ignored.

There is also `@BypassChapReference` with the same options for producing bypass chapter reference lists; these symbols should be placed at the outer level immediately after the preface, introduction, chapter or appendix that they refer to.

To produce bypass indexes, set the `@MakeIndex` setup file option to `Bypass` and use the `@BypassRawIndex` symbol repeatedly at the very end of the document, enclosed in `@BypassBeginIndex` and `@BypassEndIndex` symbols:

```
@BypassBeginIndex
@BypassRawIndex indent { 0f } { Azaleas, @PageOf azaleas }
...
@BypassEndIndex
```

The `indent` option gives the indent (0f, 1f, 2f, etc.), and the right parameter is as for `@RawIndex`. No `@PageMark` operations, sorting, merging, or attachment of page numbers will be done by Lout. When `@MakeIndex` is `Bypass`, `@Index` and related symbols are ignored. At present, bypass index symbols work only in books, not with ordinary documents or technical reports. There are corresponding symbols for creating bypass indexes A and B.

Appendix C. Lots more colours

Here is the long list of extra colours, said to be from the X windows system, that you can get by placing `@SysInclude { xrgb }` at the start of your document and using the `@Xrgb` symbol. For example, you might write













































































































```
{@Xrgb oldlace} @Colour ...
```



















































































































































































or

```
@Box paint { @Xrgb oldlace } ...
```

You can't get these colours just by giving their names; you have to use the `@Xrgb` symbol. Wherever grey appears it may also be spelt gray.

There are 541 colours here. I've removed capitalized alternative spellings and hyphens from the information provided to me. Thanks to Mark Summerfield for providing this information.

 black	 snow	 ghostwhite	 whitesmoke
 gainsboro	 floralwhite	 oldlace	 linen
 antiquewhite	 papayawhip	 blanchedalmond	 bisque
 peachpuff	 navajowhite	 moccasin	 cornsilk
 ivory	 lemonchiffon	 seashell	 honeydew
 mintcream	 azure	 aliceblue	 lavender
 lavenderblush	 mistyrose	 white	 darkslategrey
 dimgrey	 slategrey	 lightslategrey	 grey
 lightgrey	 midnightblue	 navy	 navyblue
 cornflowerblue	 darkslateblue	 slateblue	 mediumslateblue
 lightslateblue	 mediumblue	 royalblue	 blue
 dodgerblue	 deepskyblue	 skyblue	 lightskyblue
 steelblue	 lightsteelblue	 lightblue	 powderblue
 paleturquoise	 darkturquoise	 mediumturquoise	 turquoise
 cyan	 lightcyan	 cadetblue	 mediumaquamarine
 aquamarine	 darkgreen	 darkolivegreen	 darkseagreen
 seagreen	 mediumseagreen	 lightseagreen	 palegreen
 springgreen	 lawngreen	 green	 chartreuse
 mediumspringgreen	 greenyellow	 limegreen	 yellowgreen
 forestgreen	 olivedrab	 darkkhaki	 khaki
 palegoldenrod	 lightgoldenrodyellow	 lightyellow	 yellow
 gold	 lightgoldenrod	 goldenrod	 darkgoldenrod
 rosybrown	 indianred	 saddlebrown	 sienna
 peru	 burlywood	 beige	 wheat
 sandybrown	 tan	 chocolate	 firebrick
 brown	 darksalmon	 salmon	 lightsalmon
 orange	 darkorange	 coral	 lightcoral

 tomato	 orangered	 red	 hotpink
 deeppink	 pink	 lightpink	 palevioletred
 maroon	 mediumvioletred	 violetred	 magenta
 violet	 plum	 orchid	 mediumorchid
 darkorchid	 darkviolet	 blueviolet	 purple
 mediumpurple	 thistle		
 snow1	 snow2	 snow3	 snow4
 seashell1	 seashell2	 seashell3	 seashell4
 antiquewhite1	 antiquewhite2	 antiquewhite3	 antiquewhite4
 bisque1	 bisque2	 bisque3	 bisque4
 peachpuff1	 peachpuff2	 peachpuff3	 peachpuff4
 navajowhite1	 navajowhite2	 navajowhite3	 navajowhite4
 lemonchiffon1	 lemonchiffon2	 lemonchiffon3	 lemonchiffon4
 cornsilk1	 cornsilk2	 cornsilk3	 cornsilk4
 ivory1	 ivory2	 ivory3	 ivory4
 honeydew1	 honeydew2	 honeydew3	 honeydew4
 lavenderblush1	 lavenderblush2	 lavenderblush3	 lavenderblush4
 mistyrose1	 mistyrose2	 mistyrose3	 mistyrose4
 azure1	 azure2	 azure3	 azure4
 slateblue1	 slateblue2	 slateblue3	 slateblue4
 royalblue1	 royalblue2	 royalblue3	 royalblue4
 blue1	 blue2	 blue3	 blue4
 dodgerblue1	 dodgerblue2	 dodgerblue3	 dodgerblue4
 steelblue1	 steelblue2	 steelblue3	 steelblue4
 deepskyblue1	 deepskyblue2	 deepskyblue3	 deepskyblue4
 skyblue1	 skyblue2	 skyblue3	 skyblue4
 lightskyblue1	 lightskyblue2	 lightskyblue3	 lightskyblue4
 lightsteelblue1	 lightsteelblue2	 lightsteelblue3	 lightsteelblue4
 lightblue1	 lightblue2	 lightblue3	 lightblue4
 lightcyan1	 lightcyan2	 lightcyan3	 lightcyan4
 paleturquoise1	 paleturquoise2	 paleturquoise3	 paleturquoise4
 cadetblue1	 cadetblue2	 cadetblue3	 cadetblue4
 turquoise1	 turquoise2	 turquoise3	 turquoise4
 cyan1	 cyan2	 cyan3	 cyan4
 aquamarine1	 aquamarine2	 aquamarine3	 aquamarine4
 darkseagreen1	 darkseagreen2	 darkseagreen3	 darkseagreen4
 seagreen1	 seagreen2	 seagreen3	 seagreen4
 palegreen1	 palegreen2	 palegreen3	 palegreen4
 springgreen1	 springgreen2	 springgreen3	 springgreen4
 green1	 green2	 green3	 green4
 chartreuse1	 chartreuse2	 chartreuse3	 chartreuse4
 olivedrab1	 olivedrab2	 olivedrab3	 olivedrab4
 darkolivegreen1	 darkolivegreen2	 darkolivegreen3	 darkolivegreen4
 khaki1	 khaki2	 khaki3	 khaki4
 lightgoldenrod1	 lightgoldenrod2	 lightgoldenrod3	 lightgoldenrod4

	lightyellow1		lightyellow2		lightyellow3		lightyellow4
	yellow1		yellow2		yellow3		yellow4
	gold1		gold2		gold3		gold4
	goldenrod1		goldenrod2		goldenrod3		goldenrod4
	darkgoldenrod1		darkgoldenrod2		darkgoldenrod3		darkgoldenrod4
	rosybrown1		rosybrown2		rosybrown3		rosybrown4
	indianred1		indianred2		indianred3		indianred4
	sienna1		sienna2		sienna3		sienna4
	burlywood1		burlywood2		burlywood3		burlywood4
	wheat1		wheat2		wheat3		wheat4
	tan1		tan2		tan3		tan4
	chocolate1		chocolate2		chocolate3		chocolate4
	firebrick1		firebrick2		firebrick3		firebrick4
	brown1		brown2		brown3		brown4
	salmon1		salmon2		salmon3		salmon4
	lightsalmon1		lightsalmon2		lightsalmon3		lightsalmon4
	orange1		orange2		orange3		orange4
	darkorange1		darkorange2		darkorange3		darkorange4
	coral1		coral2		coral3		coral4
	tomato1		tomato2		tomato3		tomato4
	orangered1		orangered2		orangered3		orangered4
	red1		red2		red3		red4
	deeppink1		deeppink2		deeppink3		deeppink4
	hotpink1		hotpink2		hotpink3		hotpink4
	pink1		pink2		pink3		pink4
	lightpink1		lightpink2		lightpink3		lightpink4
	palevioletred1		palevioletred2		palevioletred3		palevioletred4
	maroon1		maroon2		maroon3		maroon4
	violetred1		violetred2		violetred3		violetred4
	magenta1		magenta2		magenta3		magenta4
	orchid1		orchid2		orchid3		orchid4
	plum1		plum2		plum3		plum4
	mediumorchid1		mediumorchid2		mediumorchid3		mediumorchid4
	darkorchid1		darkorchid2		darkorchid3		darkorchid4
	purple1		purple2		purple3		purple4
	mediumpurple1		mediumpurple2		mediumpurple3		mediumpurple4
	thistle1		thistle2		thistle3		thistle4

	grey0		grey1		grey2		grey3
	grey4		grey5		grey6		grey7
	grey8		grey9		grey10		grey11
	grey12		grey13		grey14		grey15
	grey16		grey17		grey18		grey19
	grey20		grey21		grey22		grey23
	grey24		grey25		grey26		grey27
	grey28		grey29		grey30		grey31

grey32
grey36
grey40
grey44
grey48
grey52
grey56
grey60
grey64
grey68
grey72
grey76
grey80
grey84
grey88
grey92
grey96
grey100

grey33
grey37
grey41
grey45
grey49
grey53
grey57
grey61
grey65
grey69
grey73
grey77
grey81
grey85
grey89
grey93
grey97

grey34
grey38
grey42
grey46
grey50
grey54
grey58
grey62
grey66
grey70
grey74
grey78
grey82
grey86
grey90
grey94
grey98

grey35
grey39
grey43
grey47
grey51
grey55
grey59
grey63
grey67
grey71
grey75
grey79
grey83
grey87
grey91
grey95
grey99

darkgrey
darkred

darkblue
lightgreen

darkcyan

darkmagenta

References

- [1] K. Jensen and N. Wirth. *Pascal User Manual and Report*. Springer-Verlag, 1975.
- [2] Brian W. Kernighan and Lorinda L. Cherry. A system for typesetting mathematics. *Communications of the ACM* **18**, 182–193 (1975).
- [3] Jeffrey H. Kingston. The design and implementation of the Lout document formatting language. *Software—Practice and Experience* **23**, 1001–1041 (1993).
- [4] Jeffrey H. Kingston. A Practical Introduction to the Lout Document Formatting System. Overhead transparencies (1994), Basser Department of Computer Science, University of Sydney.
- [5] Jeffrey H. Kingston. *An Expert’s Guide to the Lout Document Formatting System (Version 3)*. Basser Department of Computer Science, University of Sydney, 1995.
- [6] Donald E. Knuth. *The T_EXBook*. Addison-Wesley, 1984.
- [7] Leslie Lamport. *L^AT_EX User’s Guide and Reference Manual*. Addison-Wesley, 1986.
- [8] Bertrand Meyer. *Eiffel: The Language*. Prentice-Hall, 1992.
- [9] Brian K. Reid. A High-Level Approach to Computer Document Production. In *Proceedings of the 7th Symposium on the Principles of Programming Languages (POPL), Las Vegas NV*, pages 24–31, 1980.
- [10] William Strunk and E. B. White. *The Elements of Style*. Macmillan. Third Edition, 1979.
- [11] Mary-Claire van Leunen. *A Handbook for Scholars*. Oxford. Revised Edition, 1992.

Index

A

@Abbreviations, 86
above symbol (mathematics), 162
abovecaption option
 in graphs, 249
 in pie graphs, 276
aboveextra option (pie graphs), 275
abovegap option
 in graphs, 250
 in pie graphs, 276
@Abstract, 81
accented characters, 9
aformat option (tables), 130
@AL, 35
alabel option (diagrams), 201
aligned columns in tables, 138
aligned displays, 159
aligned mathematics, 159
@AlignedDisplay, 159
@AlphaList, 35
amatrix symbol (mathematics), 167
@AmberLight symbol, 143
angle option (diagrams), 191
@ANode symbol (diagrams), 190
@AnotherFootNote, 42
@Appendix
 in books, 87
 in ordinary documents, 76
 in technical reports, 82
arrow option (diagrams), 197
@Arrow symbol (diagrams), 199
arrowlength option (diagrams), 197
arrowstyle option (diagrams), 197
arrowwidth option (diagrams), 197
Article reference type, 121
axes in graphs, 246
axis (in mathematics), 157

B

@B, 13
backarrowlength option (diagrams), 198
backarrowstyle option (diagrams), 198
backarrowwidth option (diagrams), 198
background option (tables), 132
Base font, 14
base of a node in diagrams, 190
@BasicSetup, 103
@BeginAlignedDisplays, 159
@BeginAppendices
 in books, 88
 in ordinary documents, 76
 in reports, 82
@BeginChapters, 87
@BeginOverheads, 94
@BeginSections
 in books, 87
 in ordinary documents, 76
 in reports, 81
@BeginSubAppendices
 in books, 88
 in ordinary documents, 77
 in reports, 82
@BeginSubSections
 in books, 87
 in ordinary documents, 76
 in reports, 81
@BeginSubSubAppendices
 in books, 88
 in ordinary documents, 77
 in reports, 82
@BeginSubSubSections
 in books, 87
 in ordinary documents, 76
 in reports, 82
below symbol (mathematics), 162
belowcaption option
 in graphs, 249
 in pie graphs, 276
belowextra option (pie graphs), 275

belowgap option
 in graphs, 250
 in pie graphs, 276
Bezier curve, 222
@BI, 13
bias option (diagrams), 196
big symbol (mathematics), 162
bin symbol (mathematics), 168
binary operators (mathematics), 155, 167
@BL, 35
blabel option (diagrams), 201
blanklinescale, 21
blanklinescale option (programs), 288
blanknumbered option (programs), 288
Blue program printing, 284
bmatrix symbol (mathematics), 167
@BNode symbol (diagrams), 190
Bold font, 14
BoldSlope font, 14
@Book, 84
Book reference type, 120
books, 84
@BookSetup, 89
@BoundaryMarks, 109
@Box, 173
 linewidth option, 174
 margin option, 174
 paint option, 175
 texture option, 175
@Box symbol (diagrams), 191
braces
 in Lout text, 7
 in program formatting, 286
break option
 in diagrams, 193
 in tables, 131
@Break symbol, 18
brickwork texture, 172
brmatrix symbol (mathematics), 167
bsf file, 103
@Bullet, 8
@BulletList, 35
bypass symbols, 304

C

C and C++ program printing, 284
captions
 in @Figure and @Table, 47
 in graphs, 249
 in pie graphs, 276
@CD, 33
cdashed outlines (diagrams), 192
@CDot, 8
@Cell (tables), 130
@Center, 112
@CenteredDisplay, 33
@CenteredList, 34
centimetres, 5
@Centre, 112
centred entries in tables, 138
@CentredDisplay, 33
@CentredList, 34
@ChapCite (references), 117
@ChapRef (references), 117
@ChapRefListTitle (references), 125
@Chapter, 86
@ChapterStartPages, 90
@Char symbol, 8
characters, 7
Cherry, Lorinda L., ii
chessboard texture, 172
@Circle symbol (diagrams), 191
@Cite (references), 116
@CL, 34
clabel option (diagrams), 201
@Claim, 46
clines paragraph breaking style, 19
cmatrix symbol (mathematics), 167
@CNode symbol (diagrams), 190
@CNP, 17
collation order, 63
@Color, 170
@Colour, 170
colour option (graphs), 257
column width
 in pages, 70
 in tables, 137
@ColumnGap, 70
@ColumnNumber, 70
columns, 70

comments, 100
 comments option (programs), 288
 computer programs *see* programs
 contents, tables of, 57
 @ContentsGoesHere, 77
 @ContentsSeparate, 80
 @ContentsFormat, 58
 @ContentsGap, 58
 @ContentsGapAbove, 58
 @ContentsGapBelow, 58
 @ContentsLeader, 58
 @ContentsLeaderGap, 58
 @ContentsRightWidth, 58
 coordinates in diagrams, 207
 @CopyRight, 8
 @Corollary, 46
 @CoverSheet, 80
 cragged paragraph breaking style, 19
 cross references, 54
 curriculum vitae, 117
 @Curve symbol (diagrams), 198
 @CurveBox, 176
 @CurveBox symbol (diagrams), 191
 cut marks, 109

D

@D, 33
 @Dagger, 8
 @DaggerDbl, 8
 @DashJoin, 114
 dashed outlines (diagrams), 192
 dashlength option (graphs), 255
 @DashList, 35
 @Data symbol (graphs), 254
 database declarations, where to put, 105
 database files of references, 115
 database index file, 116
 @Database (references), 115
 dataformat option (graphs), 259
 @Date, 28
 in languages other than English, 27
 @DefaultIndent, 34
 @Definition, 46
 definitions, 70

definitions (*ctd.*)
 use with diagrams, 221
 use with mathematics, 160
 @Degree, 8
 @DenominatorStyle (mathematics), 162
 detach option (pie graphs), 273
 @Diag, 188
 @Diag (diagrams), 188
 diagrams
 alabel option, 201
 angle option, 191
 @ANode symbol, 190
 arrow option, 197
 @Arrow symbol, 199
 arrowlength option, 197
 arrowstyle option, 197
 arrowwidth option, 197
 backarrowlength option, 198
 backarrowstyle option, 198
 backarrowwidth option, 198
 base of a node, 190
 bias option, 196
 blabel option, 201
 @BNode symbol, 190
 @Box symbol, 191
 break option, 193
 cdashed outlines, 192
 @Circle symbol, 191
 clabel option, 201
 @CNode symbol, 190
 coordinates, 207
 @Curve symbol, 198
 @CurveBox symbol, 191
 dashed outlines, 192
 definitions, 221
 @Diamond symbol, 191
 dlabel option, 201
 @DNode symbol, 190
 dotted outlines, 192
 @Ellipse symbol, 191
 @ENode symbol, 190
 @FirstSub symbol, 209
 font option, 193
 format option, 193
 from option, 195, 211
 fromlabel option, 201

diagrams (*ctd.*)

- geometry, 225
- halign option, 195
- hindent option, 195
- hsize option, 195
- hstrut option, 195
- @HTree symbol, 212
- @Isosceles symbol, 191
- labeladjust options, 205
- labelangle options, 204
- labelbreak options, 202
- labelctr options, 205
- labelfont options, 202
- labelformat options, 202
- labelmargin options, 204
- labelpos options, 203
- labelprox options, 204
- labels, 201
- @LeftSub symbol, 209
- @Line symbol, 198
- @Link symbol, 195
- links part, 189
- margin option, 193
- @NextSub symbol, 209
- @Node symbol, 190
- nodes part, 189
- noline outlines, 192
- outline option, 190
- outlinedashlength option, 191
- outlinestyle option, 191
- outlinewidth option, 191
- paint option, 192
- path option, 195
- pathdashlength option, 197
- pathgap option, 197
- pathstyle option, 197
- pathwidth option, 197
- @Polygon symbol, 191
- positioning nodes, 206
- radius option, 196
- restrict option, 201
- @RightSub symbol, 209
- save option, 220
- shadow option, 191
- @ShadowBox symbol, 191
- sides option, 191

diagrams (*ctd.*)

- solid outlines, 192
- @Square symbol, 191
- @StubSub symbol, 210
- summary of all options, 228
- syntax diagrams, 213
- tags (::), 189, 199
- texture option, 193
- to option, 195, 211
- tolabel option, 201
- translate option, 207
- @Tree symbol, 208
- treehindent option, 212
- treehsep option, 211
- treevindent option, 212
- treevsep option, 211
- valign option, 194
- vindent option, 194
- vsize option, 194
- vstrut option, 195
- xindent option, 204
- xlabel option, 201
- ylabel option, 201
- @ZeroWidthLeftSub symbol, 211
- @ZeroWidthRightSub symbol, 211
- zindent option, 204
- zlabel option, 201
- @Diamond symbol (diagrams), 191
- dictfull PostScript error, 220
- dingbats characters, 11
- directories, Lout files and, 56
- @Display, 33
- @DisplayGap, 34
- @DisplayIndent, 34
- display style (mathematics), 154
- displayed mathematics, 158
- @DisplayGap, 18
- displays, 33
- @Divide, 8
- @DL, 35
- dlabel option (diagrams), 201
- @DLI, 36
- @DNode symbol (diagrams), 190
- @Doc, 74
- doc file, 102
- docf file, 103

@DocInfo, 99
 @Document, 74
 document types, 74
 dot symbol (mathematics), 166
 @DotJoin, 114
 @DotSep, 113
 dotdot symbol (mathematics), 166
 dotted outlines (diagrams), 192
 dotted texture, 172
 double spacing, 23
 @DP, 17
 @DropCapThree, 31
 @DropCapTwo, 31
 drop items, 36
 @DropListItem, 36
 @DropTagItem, 36
 dsf file, 103
 @DTI, 36
 dyad symbol (mathematics), 166

E

Eiffel program printing, 284
 @EL, 34
 Eliot, George, 1
 @Ellipse symbol (diagrams), 191
 elliptical arcs, 222
 em (unit of measurement), 5
 empty object, 12
 encapsulated PostScript file, 97
 @EndList, 34
 @EndAlignedDisplays, 159
 @EndAppendices
 in books, 88
 in ordinary documents, 76
 in reports, 82
 @EndChapters, 87
 @EndNote, 41
 @EndOverheads, 94
 @EndProof, 46
 @EndSections
 in books, 87
 in ordinary documents, 76
 in reports, 81
 @EndSubAppendices

@EndSubAppendices (*ctd.*)
 in books, 88
 in ordinary documents, 77
 in reports, 82
 @EndSubSections
 in books, 87
 in ordinary documents, 76
 in reports, 81
 @EndSubSubAppendices
 in books, 88
 in ordinary documents, 77
 in reports, 82
 @EndSubSubSections
 in books, 87
 in ordinary documents, 76
 in reports, 82
 @ENode symbol (diagrams), 190
 EPS file, 97
 @Eq, 153
 eqn equation formatter, ii
 equations *see* mathematics
 errors, 3
 in diagrams, 220
 in graphs, 265
 in program formatting, 296
 in pie graphs, 282
 @Euro, 8
 @EvenLeftMargin, 107
 @EvenRightMargin, 107
 @Example, 46
 expand cell width in tables, 137
 extend keyword, 223
 external labels in pie graphs, 279

F

f unit of measurement, 5
 face name of font, 13
 family name of font, 13
 @Fig, 188
 @Figure, 47
 @FigureCaptionPos, 50
 @FigureFormat, 50
 @FigureLocation, 48
 @FigureNumbers, 50

figures, 47
 filledxhisto option (graphs), 257
 filledyhisto option (graphs), 257
 finger option (pie graphs), 281
 fingerdashlength option (pie graphs), 281
 fingers in pie graphs, 280
 fingerstyle option (pie graphs), 281
 fingerwidth option (pie graphs), 281
 @FirstPageNumber, 110
 @FirstSub symbol (diagrams), 209
 fixed style (programs), 287
 @Florin, 8
 fmatrix symbol (mathematics), 167
 font option
 in diagrams, 193
 in program formatting, 288
 in tables, 131
 font size, 15
 @Font symbol, 15
 @FootMargin, 107
 @FootAboveGap, 43
 @FootGap, 43
 @FootLen, 43
 @FootNote, 41
 @FootNoteBreak, 43
 @FootNoteFont, 43
 @FootNoteLocation, 42
 @FootNoteNumbers, 42
 @FootNoteThrough, 42
 form-feed in plain text, 99
 format option (diagrams), 193
 format of tables option (tables), 130, 134
 formfeed characters in programs, 292
 frac symbol (mathematics), 167
 from option (diagrams), 195, 211
 fromlabel option (diagrams), 201
 @FullWidth, 75
 @FullWidthRule, 177

G

geometry in diagrams, 225
 GNU Public License, ii
 @Graph, 245
 graph file, 245

@GraphCircle symbol (graphs), 263
 @GraphCross symbol (graphs), 263
 @GraphDashed symbol (graphs), 263
 @GraphDiamond symbol (graphs), 263
 @GraphDotDashed symbol (graphs), 263
 @GraphDotDotDashed symbol (graphs),
 263
 @GraphDotDotDotDashed symbol (graphs),
 263
 @GraphDotted symbol (graphs), 263
 @GraphFilledCircle symbol (graphs), 263
 @GraphFilledDiamond symbol (graphs),
 263
 @GraphFilledSquare symbol (graphs), 263
 @GraphFilledTriangle symbol (graphs), 263
 @GraphNoLine symbol (graphs), 263
 @GraphPlus symbol (graphs), 263
 @GraphSolid symbol (graphs), 263
 @GraphSquare symbol (graphs), 263
 @GraphTriangle symbol (graphs), 263
 graphics (basic), 170
 see also diagrams, graphs, pie graphs
 graphs (statistical), 245
 abovecaption option, 249
 abovegap option, 250
 belowcaption option, 249
 belowgap option, 250
 captions, 249
 colour option, 257
 dashlength option, 255
 @Data symbol, 254
 dataformat option, 259
 errors, 265
 filledxhisto option, 257
 filledyhisto option, 257
 @GraphCircle symbol, 263
 @GraphCross symbol, 263
 @GraphDashed symbol, 263
 @GraphDiamond symbol, 263
 @GraphDotDashed symbol, 263
 @GraphDotDotDashed symbol, 263
 @GraphDotDotDotDashed symbol, 263
 @GraphDotted symbol, 263
 @GraphFilledCircle symbol, 263
 @GraphFilledDiamond symbol, 263
 @GraphFilledSquare symbol, 263

graphs (statistical) (*ctd.*)

- @GraphFilledTriangle symbol, 263
- @GraphNoLine symbol, 263
- @GraphPlus symbol, 263
- @GraphSolid symbol, 263
- @GraphSquare symbol, 263
- @GraphTriangle symbol, 263
- height option, 248
- hidecaptions option, 250
- histograms, 255
- keys, 263
- labels, 251
- leftcaption option, 249
- leftgap option, 250
- linewidth option, 255
- mathematical functions, 260
- objects option, 260
- paint option, 258
- pairs option, 254
- points option, 254
- rightcaption option, 249
- rightgap option, 250
- rticks option, 252
- save option, 265
- style option, 246
- summary of all options, 265
- surfacexhisto option, 257
- surfaceyhisto option, 256
- symbolsize option, 254
- texture option, 258
- ticks, 251
- width option, 248
- xdecreasing option, 249
- xextra option, 248
- xhisto option, 257
- xlog option, 248
- xmax option, 251
- xmin option, 251
- xorigin option, 246
- xticklength option, 252
- xticks option, 251
- xticksep option, 251
- ydecreasing option, 249
- yextra option, 248
- yhisto option, 255
- ylog option, 248

graphs (statistical) (*ctd.*)

- ymax option, 252
- ymin option, 252
- yorigin option, 246
- yticklength option, 252
- yticks option, 252
- yticksep option, 252

grid texture, 172

H

- halign option (diagrams), 195
- Harvey, W. J., 1
- Haskell program printing, 284
- hat symbol (mathematics), 166
- @HeaderRow symbols (tables), 145
- @Heading, 16
- @HeadingFont, 17
- height option
 - in graphs, 248
 - in tables, 138
- @HEexpand, 184
- hidecaptions option
 - in graphs, 250
 - in pie graphs, 276
- @High, 184
- hindent option (diagrams), 195
- histograms, 255
- @HMirror, 181
- honeycomb texture, 172
- @HShift, 185
- hsize option (diagrams), 195
- @HSpan option (tables), 140
- hstrut option (diagrams), 195
- @HTree symbol (diagrams), 212
- Hungarian and @NumSep, 114
- hyphenation, 24
 - in languages other than English, 26

I

- @I, 13
- @ID, 33
- identifiers option (programs), 288

@II, 13
 @IL, 34
 @Illustration, 97
 illustrations, 96
 import, 71
 InBook reference type, 122
 inches, 5
 @Include, 100
 @IncludeGraphic, 182
 including an illustration, 182
 @Include within programs, 295
 @IncludeGraphicRepeated, 182
 indent option (tables), 138
 @IndentedDisplay, 33
 @IndentedList, 34
 indentvertical option (tables), 138
 index file, 116
 @Index symbol, 63
 @IndexBlanks, 66
 @IndexBreak, 68
 @IndexColumnGap, 68
 @IndexColumnNumber, 68
 @IndexCtd, 68
 @IndexCtdFormat, 68
 @IndexCtdWord, 68
 indexes, 62
 @IndexFont, 68
 @IndexFormat, 68
 @IndexLetters, 67
 @IndexSpacer, 66
 @IndexSpacerAbove, 69
 @IndexSpacerBelow, 69
 @IndexSpacerFont, 69
 @IndexSpacerFormat, 69
 initialangle option (pie graphs), 274
 @InitialBreak, 23
 @InitialFont, 16
 @InitialIndexSpacer, 67
 @InitialLanguage, 27
 @InitialSpace option, 31
 InProceedings reference type, 122
 @IntroFirstPageNumber, 110
 @IntroPageNumbers, 110
 intro and non-intro pages, 111
 @Introduction, 86
 ISO-LATIN-1 character set, 8

@Isosceles symbol (diagrams), 191

J

Java program printing, 284

K

keeping things on one line, 19

Kernighan, Brian W., ii

kerning, 16

keys in graphs, 263

keywords option (programs), 288

Knuth, D. E., ii, 153

L

@L, 38

@Label (references), 118

labeladjust options

in diagrams, 205

in pie graphs, 278

labelangle options (diagrams), 204

labelbreak options

in diagrams, 202

in pie graphs, 277

labelctr options (diagrams), 205

labelfont options

in diagrams, 202

in pie graphs, 277

labelformat options

in diagrams, 202

in pie graphs, 277

labelled references, 118

labelmargin options

in diagrams, 204

in pie graphs, 277

labelpos options (diagrams), 203

labelprox options (diagrams), 204

labelradius option (pie graphs), 278

labels

in diagrams, 201

in graphs, 251

labels (*ctd.*)
 in pie graphs, 277
 langdefs file, 103
 @Language, 26
 languages other than English, 26
 large operators (mathematics), 155, 166
 large-scale structure, 51
 largeop symbol (mathematics), 167
 last.page tag, 54
 L^AT_EX, 115
 @LD, 33
 .ld file, 115
 @Lecture, 94
 leftcaption option
 in graphs, 249
 in pie graphs, 276
 @LeftDisplay, 33
 leftextra option (pie graphs), 275
 leftgap option
 in graphs, 250
 in pie graphs, 276
 @LeftList, 34
 @LeftNote, 43
 @LeftSub symbol (diagrams), 209
 @Lemma, 46
 length, 5
 @LI, 34
 .li file, 116
 ligatures, 16
 and hyphenation, 24
 line adjustment, 19
 @Line symbol (diagrams), 198
 line option (programs), 288
 line spacing, 23
 lines paragraph breaking style, 19
 linewidth option (graphs), 255
 @Link symbol (diagrams), 195
 links part in diagrams, 189
 @List, 38
 @ListItem, 34
 list symbol options, 38
 lists, 34
 in languages other than English, 27
 @LL, 34
 @LLP, 17
 @LocalWidthRule, 177

@Location, 47
 logarithmic axes in graphs, 248
 @LOP, 17
 lout.li file, 56
 lout spacing, 32
 Lout code embedded in programs, 293
 @Lozenge, 8
 @LP, 17

M

@M (mathematics), 154
 @MajorNum, 113
 @MajorTitle, 113
 @MakeContents, 58
 @MakeIndex, 67
 @MakeReferences (references), 123
 margin kerning, 24
 margin options
 in diagrams, 193
 in pages, 107
 in tables, 136
 margin notes, 43
 MastersThesis reference type, 121
 @Math (mathematics), 153
 math file, 153
 mathematical functions in graphs, 260
 mathematics, 153
 above symbol, 162
 amatrix symbol, 167
 axis of, 157
 below symbol, 162
 big symbol, 162
 bin symbol, 168
 binary operators, 155, 167
 bmatrix symbol, 167
 brmatrix symbol, 167
 cmatrix symbol, 167
 definitions, use with, 160
 @DenominatorStyle, 162
 display style, 154
 dot symbol, 166
 dotted symbol, 166
 dyad symbol, 166
 fmatrix symbol, 167

mathematics (*ctd.*)
 frac symbol, 167
 hat symbol, 166
 large operators, 155, 166
 largeop symbol, 167
 @M, 154
 @Math, 153
 matrix symbol, 155
 non symbol, 162
 @NumeratorStyle, 162
 on symbol, 166
 ordinary symbols, 163
 over symbol, 155, 167
 overbar symbol, 166
 pmatrix symbol, 167
 precedence of symbols, 155, 161
 punct symbol, 169
 punctuation symbols, 169
 rel symbol, 169
 relation symbols, 155, 168
 root symbol, 167
 small symbol, 162
 sqrt symbol, 155, 167
 @SquareRootStyle, 162
 sub symbol, 154, 166
 @SubScriptStyle, 162
 sup symbol, 155, 166
 @SuperScriptStyle, 162
 supp symbol, 166
 text style, 154
 tilde symbol, 166
 ton symbol, 166
 tsub symbol, 166
 unary operators, 167
 underbar symbol, 166
 variable-building symbols, 166
 vctr symbol, 162
 vec symbol, 166
 wideabove symbol, 162
 widebelow symbol, 162
 matrix symbol (mathematics), 155
 @MinorNum, 113
 @MinorTitle, 113
 @Minute, 8
 Mirror images, 181
 Misc reference type, 121

multi-page tables, 144
 multiple columns, 70
 multiple runs, why needed, 55
 @Multiply, 8
 mydefs file, 71
 mydoc file, 102
 mystyle.ld file, 126

N

new page, 17
 @NextSub symbol (diagrams), 209
 @NL, 34
 @NoChapCite (references), 117
 @NoChapRef (references), 117
 @NoCite (references), 117
 @NoRef (references), 117
 @NoBreakRow symbols (tables), 144
 @Node symbol (diagrams), 190
 nodes part in diagrams, 189
 @NoDotJoin, 114
 @NoDotSep, 114
 noline outlines (diagrams), 192
 non symbol (mathematics), 162
 Nonpareil program printing, 284
 @NP (new page), 17
 in tables, 144
 @Null, 112
 @NumSep, 114
 numbered displays, 159
 numbered mathematics, 159
 numbered option (programs), 288
 @NumberedDisplay, 159
 @NumberedList, 34
 @NumberOf, 55
 numbers option (programs), 288
 @NumberSeparator, 54
 @NumeratorStyle (mathematics), 162

O

object, 4
 objects option (graphs), 260
 @OddLeftMargin, 107

odd and even pages, 111
 @OddRightMargin, 107
 olines paragraph breaking style, 19
 on symbol (mathematics), 166
 @OneCol, 183
 @OneRow, 183
 operators option (programs), 288
 option, 5
 oragged paragraph breaking style, 19
 ordinary documents symbols (mathematics),
 74, 163
 @OrdinarySetup, 77
 organizing large documents, 100
 orphan lines, 23
 outdented paragraphs, 19
 @OuterNote, 43
 outline option (diagrams), 190
 @Outline symbol, 177
 outlinedashlength option
 in diagrams, 191
 in pie graphs, 273
 outlinestyle option
 in diagrams, 191
 in pie graphs, 273
 outlinewidth option
 in diagrams, 191
 in pie graphs, 273
 over symbol (mathematics), 155, 167
 overbar symbol (mathematics), 166
 @Overhead, 93
 @OverheadSetup, 95
 @OverheadTransparencies, 92
 overhead transparencies, 92
 @OverStrike, 186, 248

P

page, skipping to next, 17
 @PageBackground, 109
 @PageBoxType, 108
 page footer, 110
 page header, 110
 @PageHeaders, 110
 @PageHeight, 106
 @PageNum, 112

@PageNumbers, 110
 @PageOrientation, 106
 @PageType, 105
 @PageWidth, 106
 @PageMark, 54
 @PageNumberFormat, 114
 @PageOf, 54
 @PageParityOf, 55
 paint option
 in diagrams, 192
 in graphs, 258
 in pie graphs, 272
 in tables, 131
 pairs option (graphs), 254
 @PAL, 35
 @ParaGap, 18
 paragraph breaking, 18
 @ParagraphItem, 37
 paragraph symbols, 17
 @ParaIndent, 18
 @ParenAlphaList, 35
 @ParenNumberedList, 35
 @ParenRomanList, 35
 @ParenUCAAlphaList, 35
 @ParenUCRomanList, 35
 @ParSym, 8
 @PartNumber, 88
 @PartText, 88
 @PartTitle, 88
 parts of books, 88
 @Pas, 299
 Pascal programs, 299
 path option (diagrams), 195
 pathdashlength option (diagrams), 197
 pathgap option (diagrams), 197
 pathstyle option (diagrams), 197
 pathwidth option (diagrams), 197
 PDF documents, 99
 Perl program printing, 284
 Perl problems (programs), 296
 PhDThesis reference type, 121
 @PI, 37
 @Pie symbol, 270
 pie setup file, 270
 pie graphs, 270
 abovecaption option, 276

- pie graphs (*ctd.*)
 - aboveextra option, 275
 - abovegap option, 276
 - belowcaption option, 276
 - belowextra option, 275
 - belowgap option, 276
 - captions, 276
 - detach option, 273
 - errors, 282
 - external labels, 279
 - finger option, 281
 - fingerdashlength option, 281
 - fingers, 280
 - fingerstyle option, 281
 - fingerwidth option, 281
 - hidecaptions option, 276
 - initialangle option, 274
 - labeladjust option, 278
 - labelbreak option, 277
 - labelfont option, 277
 - labelformat option, 277
 - labelmargin option, 277
 - labelradius option, 278
 - labels, 277
 - leftcaption option, 276
 - leftextra option, 275
 - leftgap option, 276
 - outlinedashlength option, 273
 - outlinestyle option, 273
 - outlinewidth option, 273
 - overall appearance, 274
 - paint option, 272
 - radius option, 274
 - rightcaption option, 276
 - rightextra option, 275
 - rightgap option, 276
 - save option, 282
 - @Slice symbol, 271
 - summary, 283
 - texture option, 272
 - totalweight option, 272
 - weight option, 272
- pipe option (programs), 295
- @Pipe, 30
- @PipeRawVerbatim, 30
- @PipeVerbatim, 30
- @Place, 44
- plain text documents, 98
- plain text tables, 147
- pmatrix symbol (mathematics), 167
- @PNL, 35
- Pod (for Perl) printing, 284
- Pod problems (programs), 297
- point (unit of measurement), 5
- points option (graphs), 254
- @Polygon (diagrams), 191
- positioning nodes in diagrams, 206
- @PP, 17
- precedence of symbols (mathematics), 155, 161
- @Preface, 85
- preventing line breaks, 19
- prg2lout filter program, 284
- @PRL, 35
- Proceedings reference type, 121
- programs, 284
 - blanklinescale option, 288
 - blanknumbered option, 288
 - braces in, 286
 - comments option, 288
 - errors, 296
 - fixed style, 287
 - font option, 288
 - formfeed characters in, 292
 - identifiers option, 288
 - @Include within, 295
 - keywords option, 288
 - line option, 288
 - Lout code embedded in, 293
 - numbered option, 288
 - numbers option, 288
 - operators option, 288
 - Perl problems, 296
 - pipe option, 295
 - Pod problems, 297
 - program text in comments, 294
 - setup files for, 289
 - size option, 288
 - space option, 288
 - stand-alone, 284
 - strings option, 288
 - style option, 287

programs (*ctd.*)
 symbol style, 287
 tab characters, 291
 tabin option, 291
 tabout option, 291
 varying style, 287
 program text in program comments, 294
 @Proof, 46
 @Proposition, 46
 @PUCAL, 35
 @PUCRL, 35
 punct symbol (mathematics), 169
 punctuation symbols (mathematics), 169
 Python program printing, 284

Q

@QD, 33
 @QL, 34
 quote characters, 8
 @QuotedDisplay, 33
 @QuotedList, 34

R

@R, 13
 radius option
 in diagrams, 196
 in pie graphs, 274
 ragged paragraph breaking style, 19
 railroad diagrams, 213
 raw displays, 160
 @RawEndList, 36
 @RawList, 36
 raw lists, 36
 @RawVerbatim, 30
 @RawIndex symbol, 63
 @Ref (references), 117
 @RefCiteLabels (references), 123
 @RefCiteStyle (references), 123
 @Reference (references), 115
 references, 115
 Article reference type, 121
 Book reference type, 120

references (*ctd.*)
 @ChapCite, 117
 @ChapRefListTitle, 125
 @Cite, 116
 @Database, 115
 database.files, 115
 database index file, 116
 InBook reference type, 122
 InProceedings reference type, 122
 @Label, 118
 labelled, 118
 @MakeReferences, 123
 MastersThesis reference type, 121
 Misc reference type, 121
 @NoChapCite, 117
 @NoCite, 117
 PhDThesis reference type, 121
 Proceedings reference type, 121
 @RefCiteLabels, 123
 @RefCiteStyle, 123
 @Reference, 115
 @ReferencesBeforeAppendices, 90
 @RefListBreak, 125
 @RefListFont, 125
 @RefListFormat, 124
 @RefListGap, 125
 @RefListIndent, 125
 @RefListLabels, 124
 @RefListLabelWidth, 125
 @RefListRightIndent, 125
 @RefListSortKey, 125
 @RefListTitle, 124
 @RefNumbers, 124
 @RefPrint, 117
 @RefStyle, 126
 @SysDatabase, 126
 @Tag, 115
 TechReport reference type, 121
 @Type option, 115
 @URL, 120
 Reflected objects, 181
 @RefListBreak (references), 125
 @RefListFont (references), 125
 @RefListFormat (references), 124
 @RefListGap (references), 125
 @RefListIndent (references), 125

- @RefListLabels (references), 124
 - @RefListLabelWidth (references), 125
 - @RefListRightIndent (references), 125
 - @RefListSortKey (references), 125
 - @RefListTitle (references), 124
 - @RefNumbers (references), 124
 - @RefPrint (references), 117
 - refs.ld file, 115
 - refstyle.ld file, 126
 - @RefStyle (references), 126
 - @Register, 8
 - Reid, Brian K., ii
 - rel symbol (mathematics), 169
 - relation symbols (mathematics), 155, 168
 - @Report, 78
 - @ReportSetup, 83
 - reports, 78
 - restrict option (diagrams), 201
 - resumes, 117
 - @Right, 112
 - right justified entries in tables, 138
 - rightcaption option
 - in graphs, 249
 - in pie graphs, 276
 - @RightDisplay, 33
 - rightextra option (pie graphs), 275
 - rightgap option
 - in graphs, 250
 - in pie graphs, 276
 - @RightNote, 43
 - @RightSub symbol (diagrams), 209
 - @RL, 35
 - rlines paragraph breaking style, 19
 - Roman numerals, 35
 - @RomanList, 35
 - root symbol (mathematics), 167
 - @Rotate, 178
 - rotated entries in tables, 132
 - row formats in tables, 133
 - @Rowa (tables), 130
 - rragged paragraph breaking style, 19
 - RSL program printing, 284
 - rticks option (graphs), 252
 - Ruby program printing, 284
 - rule options (tables), 134
 - ruleplainchar option (tables), 148
 - rules, 177
 - running header, 110
 - @RunningTitle, 52
- ## S
- @S, 13
 - s unit of measurement, 5
 - save option
 - in diagrams, 220
 - in graphs, 265
 - in pie graphs, 282
 - @Scale, 178
 - Scribe
 - influence on Lout, ii
 - reference formatting, 115
 - @Second, 8
 - @Section
 - in books, 87
 - in ordinary documents, 76
 - in reports, 81
 - @SectionGap, 17
 - @SectSym, 8
 - @SeparateIntroNumbering, 90
 - setup files, 102
 - for programs, 289
 - for tables, 148
 - shadow option (diagrams), 191
 - @ShadowBox, 176
 - @ShadowBox symbol (diagrams), 191
 - sides option (diagrams), 191
 - size option (programs), 288
 - @SL, 35
 - @Slice symbol (pie graphs), 271
 - slides *see* overhead transparencies
 - Slope font, 14
 - small symbol (mathematics), 162
 - small capitals, 13
 - solid outlines (diagrams), 192
 - solid texture, 172
 - sorting of reference lists, 125
 - sorting order, 63
 - space option (programs), 288
 - spacers in indexes, 66
 - spaces, significance of, 6

spanning columns and rows in tables, 140
 sqrt symbol (mathematics), 155, 167
 @Square symbol (diagrams), 191
 @SquareRootStyle (mathematics), 162
 stand-alone illustrations, 96
 stand-alone programs, 284
 standard.ld file, 128
 @Star, 8
 @StarList, 35
 start and non-start pages, 111
 @StartHSpan option (tables), 140
 @StartHVSspan option (tables), 142
 @StartVSpan option (tables), 141
 @Sterling, 8
 string texture, 172
 strings option (programs), 288
 striped texture, 172
 @StructPageNums, 114
 strut option
 in tables, 138
 struthorizontal option (tables), 138
 @StubSub symbol (diagrams), 210
 style option
 in graphs, 246
 in programs, 287
 sub symbol (mathematics), 154, 166
 @SubAppendix
 in books, 88
 in ordinary documents, 77
 in reports, 82
 @SubIndex symbol, 63
 @SubScriptStyle (mathematics), 162
 @SubSection
 in books, 87
 in ordinary documents, 76
 in reports, 81
 @SubSubAppendix
 in books, 88
 in ordinary documents, 77
 in reports, 82
 @SubSubSection
 in books, 87
 in ordinary documents, 76
 in reports, 82
 summary of all options for diagrams, 228
 sup symbol (mathematics), 155, 166

@SuperScriptStyle (mathematics), 162
 supp symbol (mathematics), 166
 surfacexhisto option (graphs), 257
 surfaceyhisto option (graphs), 256
 @Sym symbol, 10
 Symbol font, 10
 symbol style (programs), 287
 symbols, makeup of, 6
 symbolsize option (graphs), 254
 syntax diagrams, 213
 @SysDatabase, 126
 @SysInclude, 102
 system database directory, 126
 system include directory, 102

T

tab characters in programs, 291
 tabin option (programs), 291
 @Table, 47
 @TableCaptionPos, 50
 @TableFormat, 50
 @TableLocation, 48
 @TableNumbers, 50
 tables, 129
 aformat option, 130
 aligned columns, 138
 background option, 132
 break option, 131
 @Cell, 130
 expand cell width, 137
 font option, 131
 format of, 130
 format option, 134
 @HeaderRow symbols, 145
 height option, 138
 @HSpan option, 140
 indent option, 138
 indentvertical option, 138
 margin options, 136
 @MarkRow symbols, 143
 multi-page, 144
 @NoBreakRow symbols, 144
 @NP (new page) in, 144
 paint option, 131

- tables (*ctd.*)
 - plain text output, 147
 - row formats, 133
 - @Rowa, 130
 - rule options, 134
 - ruleplainchar option, 148
 - setup file, 148
 - spanning columns and rows, 140
 - @StartHSpan option, 140
 - @StartHVSpan option, 142
 - @StartVSpan option, 141
 - strut option, 138
 - struthorizontal option, 138
 - summary of all options, 149
 - @Tbl, 129
 - texture option, 131
 - vertical alignment of, 143
 - @VSpan option, 141
 - width option, 137
 - tables of contents, 57
 - tabout option (programs), 291
 - @Tag option, 55
 - in references, 115
 - @TaggedList, 35
 - @TagItem, 35
 - tags (::) in diagrams, 189, 199
 - tbl file, 129
 - @Tbl (tables), 129
 - technical reports, 78
 - TechReport reference type, 121
 - \TeX , ii, 153
 - hyphenation, 24
 - page optimization, 76
 - paragraph breaking, 18
 - tex (\LaTeX) spacing, 32
 - text style (mathematics), 154
 - texture option
 - in diagrams, 193
 - in graphs, 258
 - in pie graphs, 272
 - in tables, 131
 - @Texture symbol, 171
 - angle option, 171
 - hshift option, 171, 173
 - scale option, 171
 - vshift option, 171, 173
 - @Theorem, 45
 - @MarkRow symbols (tables), 143
 - @TI, 35
 - ticks in graphs, 251
 - tilde symbol (mathematics), 166
 - @Time, 28
 - in languages other than English, 27
 - @Title, 51
 - @TitlePageFont, 90
 - @TitleOf, 55
 - @TL, 35
 - to option (diagrams), 195, 211
 - tolabel option (diagrams), 201
 - ton symbol (mathematics), 166
 - @TopMargin, 107
 - totalweight option (pie graphs), 272
 - @TradeMark, 8
 - translate option (diagrams), 207
 - @Tree symbol (diagrams), 208
 - treehindent option (diagrams), 212
 - treehsep option (diagrams), 211
 - treevindent option (diagrams), 212
 - treevsep option (diagrams), 211
 - triangular texture, 172
 - troff spacing, 32
 - tsub symbol (mathematics), 166
 - @Type (references), 115
- ## U
- @UCAL, 35
 - @UCAAlphaList, 35
 - @UCRL, 35
 - @UCRomanList, 35
 - unary operators (mathematics), 167
 - unbreakablefirst, 23
 - unbreakablelast, 23
 - underbar symbol (mathematics), 166
 - @Underline, 25
 - units of measurement, 5
 - @Unpaginated, 99
 - @URL (references), 120
 - @Use, 103

V

v unit of measurement, 5
 valign option (diagrams), 194
 van Leunen, Mary-Claire, 115
 variable-building symbols (mathematics), 166
 varying style (programs), 287
 vctr symbol (mathematics), 162
 vec symbol (mathematics), 166
 @Verbatim, 29
 vertical alignment of tables, 143
 @VeryWideTaggedList, 35
 @VExpand, 185
 vindent option (diagrams), 194
 VMerror PostScript error, 220
 @VMirror, 181
 @VShift, 182, 185
 vsize option (diagrams), 194
 @VSpan option (tables), 141
 @VStrut, 185
 vstrut option (diagrams), 195
 @VWTL, 35

W

weight option (pie graphs), 272
 @Wide, 183
 with illustrations, 97
 with @Rotate, 178
 with @Scale, 179
 wideabove symbol (mathematics), 162
 widebelow symbol (mathematics), 162
 @WideTaggedList, 35
 widow lines, 23
 width option
 in graphs, 248
 in tables, 137
 @WTL, 35

X

xdecreasing option (graphs), 249
 xextra option (graphs), 248

xhisto option (graphs), 257
 xindent option (diagrams), 204
 xlabel option (diagrams), 201
 xlog option (graphs), 248
 xmax option (graphs), 251
 xmin option (graphs), 251
 xorigin option (graphs), 246
 @Xrgb symbol, 306
 xticklength option (graphs), 252
 xticks option (graphs), 251
 xticksep option (graphs), 251

Y

ydecreasing option (graphs), 249
 @Yen, 8
 yextra option (graphs), 248
 yhisto option (graphs), 255
 ylabel option (diagrams), 201
 ylog option (graphs), 248
 ymax option (graphs), 252
 ymin option (graphs), 252
 yorigin option (graphs), 246
 yticklength option (graphs), 252
 yticks option (graphs), 252
 yticksep option (graphs), 252

Z

@ZeroHeight, 186
 @ZeroWidth, 186
 @ZeroWidthLeftSub (diagrams), 211
 @ZeroWidthRightSub (diagrams), 211
 zindent option (diagrams), 204
 zlabel option (diagrams), 201